

**GT**  
**MOMENTUM™**

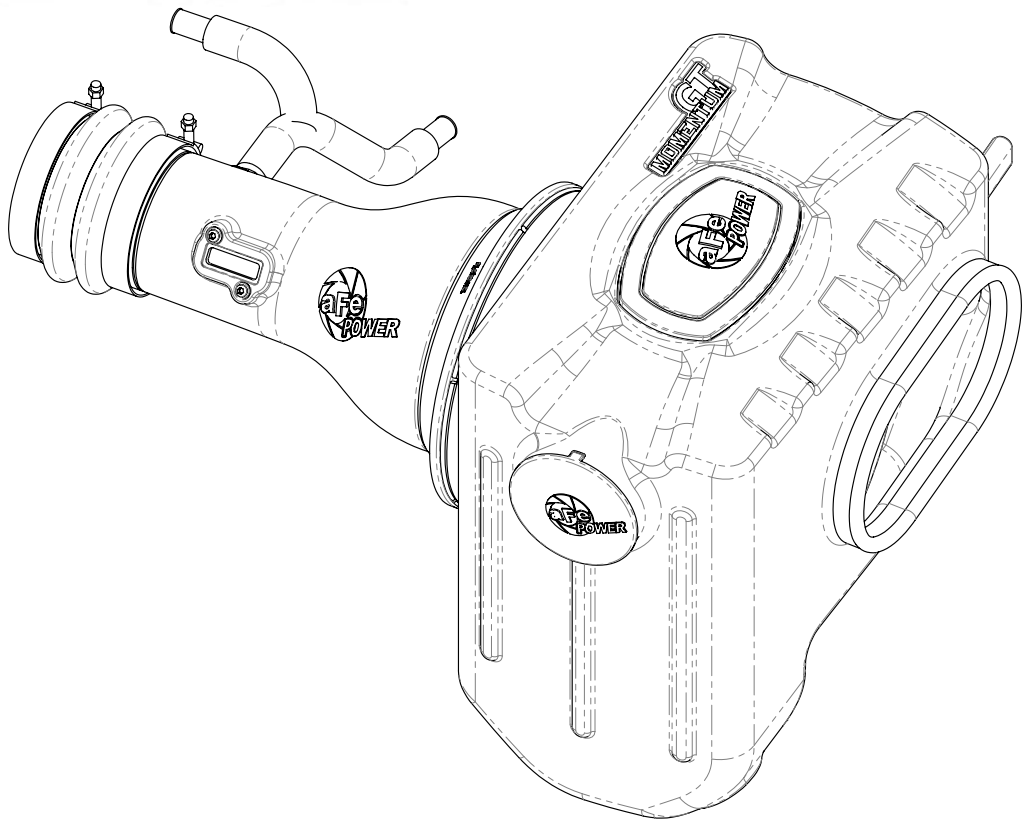

**advanced FLOW engineering** Momentum GT Cold Air Intake System

**Instruction Manual** P/N: 50-70034D / 50-70034R

Make: **Nissan**

Model: **Titan XD**

Year: **2017-2019**

Engine: **V8-5.6L**



- Please read the entire instruction manual before proceeding.
- Ensure all components listed are present.
- If you are missing any of the components, call customer support at 951-493-7100.
- Ensure you have all necessary tools before proceeding.
- Do not attempt to work on your vehicle when the engine is hot.

## Retain factory parts for future use.

Label	Qty.	Description	Part Number
A1	1	Air Filter (Pro 5R)	24-91059
A2	1	Air Filter (Pro DRY S)	21-91059
B	1	Tube	05-5070034B1
C	1	Housing	05-5070034B2
D	1	Coupling, Silicone Bellows	05-01389
E	1	Plug, Airbox	05-01361
F	1	Hose, Adaptor CCV (Silicone)	05-01346
G	1	Fitting, 5/8"	03-50541
H	2	Screw, Torx: M4	03-50491
I	1	Clamp, T-bolt (8-5/16" - 8-5/8")	03-50267
J	2	Clamp, T-bolt (3-13/16" - 4-1/8")	03-50265
K	1	Seal, Trim: 7/16" Bulb (23" inches)	05-00072

### Installation will require the following tools:

Flat head screwdriver, 8mm & 10mm nut drivers and pliers.

**Emissions Disclaimer:** This product is not currently CARB exempt and is not available for purchase in California or for use on any vehicle registered with the California Department of Motor Vehicles.

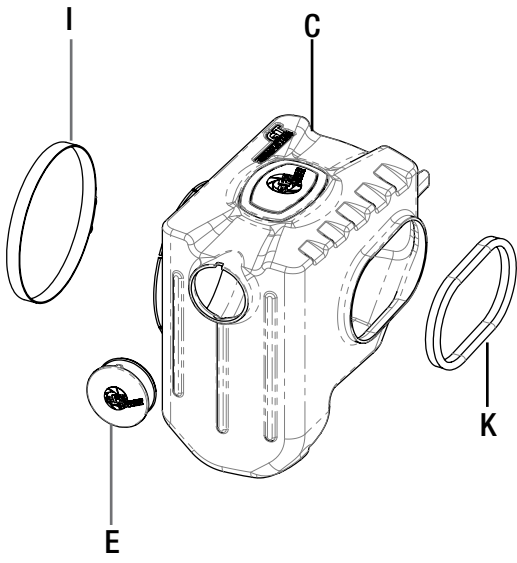
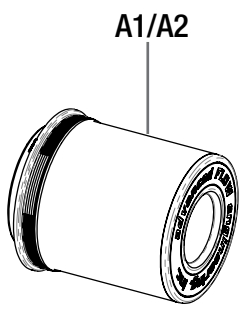
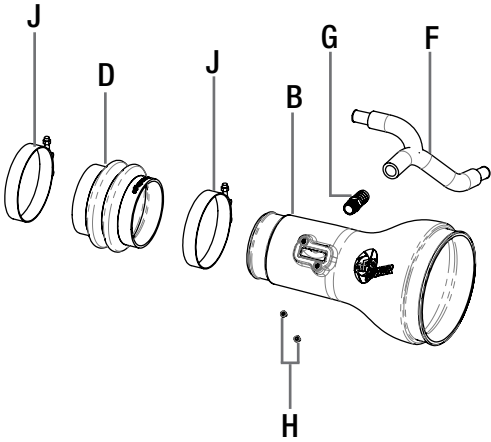



Figure A

**Refer to Figure A for Step 1**

Step 1: Remove the cover by pulling up and toward the front bumper cover ①.



Figure B

**Refer to Figure B for Steps 2-4**

Step 2: Use a 10mm nut driver to remove the screw at the back of the factory airbox (2).

Step 3: With the 8mm nut driver, loosen the band clamp at the throttle body (3).

Step 4: Disconnect the MAF harness from the MAF sensor on the factory intake tube (4) and carefully detach the MAF harness from the factory airbox.

**Figure C****Refer to Figure C for Steps 5-8**

Step 5: Compress the metal spring clamps on both crank case vent hoses (5) and slide down each hose.

Step 6: Disconnect both CCV hoses from the resonance chamber and position out of the way.

Step 7: Unclip and remove both plastic clips (6) connecting the rubber evap hose to the resonance chamber.

Step 8: Remove the entire factory intake system from the engine bay.

**NOTE: Check the factory airbox for any additional hoses that must be detached, to remove the factory intake system.**



Figure D

**Refer to Figure D for Step 9**

Step 9: Remove the factory scoop from the vehicle by detaching the factory clips (7).

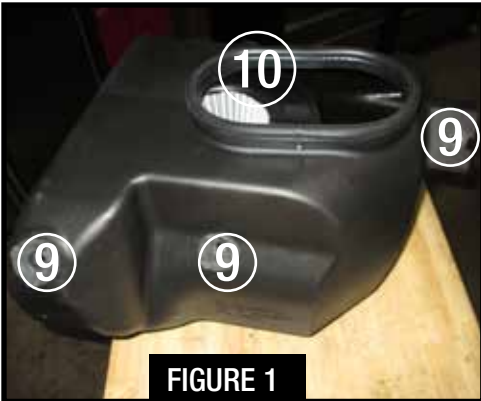

**Refer to Figure E for Steps 10-13**

- Step 10: Insert the aFe POWER air filter into the housing and slip the larger clamp over the filter-to-housing interface (8). Tighten the clamp.
- Step 11: Remove the three (3x) rubber grommets (9) and one (1x) steel sleeve from the factory airbox and transfer them to the aFe POWER housing, as shown in Figure 1.
- Step 12: Install the supplied trim seal (10), as shown in Figure 1.
- Step 13: Install the aFe POWER housing into the vehicle and tighten the factory bolt, removed in Step 2.



**Figure F****Refer to Figure F for Step 14**

Step 14: If desired, install the supplied aFe POWER plug ⑪ .

**NOTE:** Without the plug installed, the aFe POWER intake will capture the maximum air available. More airflow offers more power. Some of this air is picked up from inside the engine compartment and could be warmer air. Warmer air will affect the performance of the vehicle.

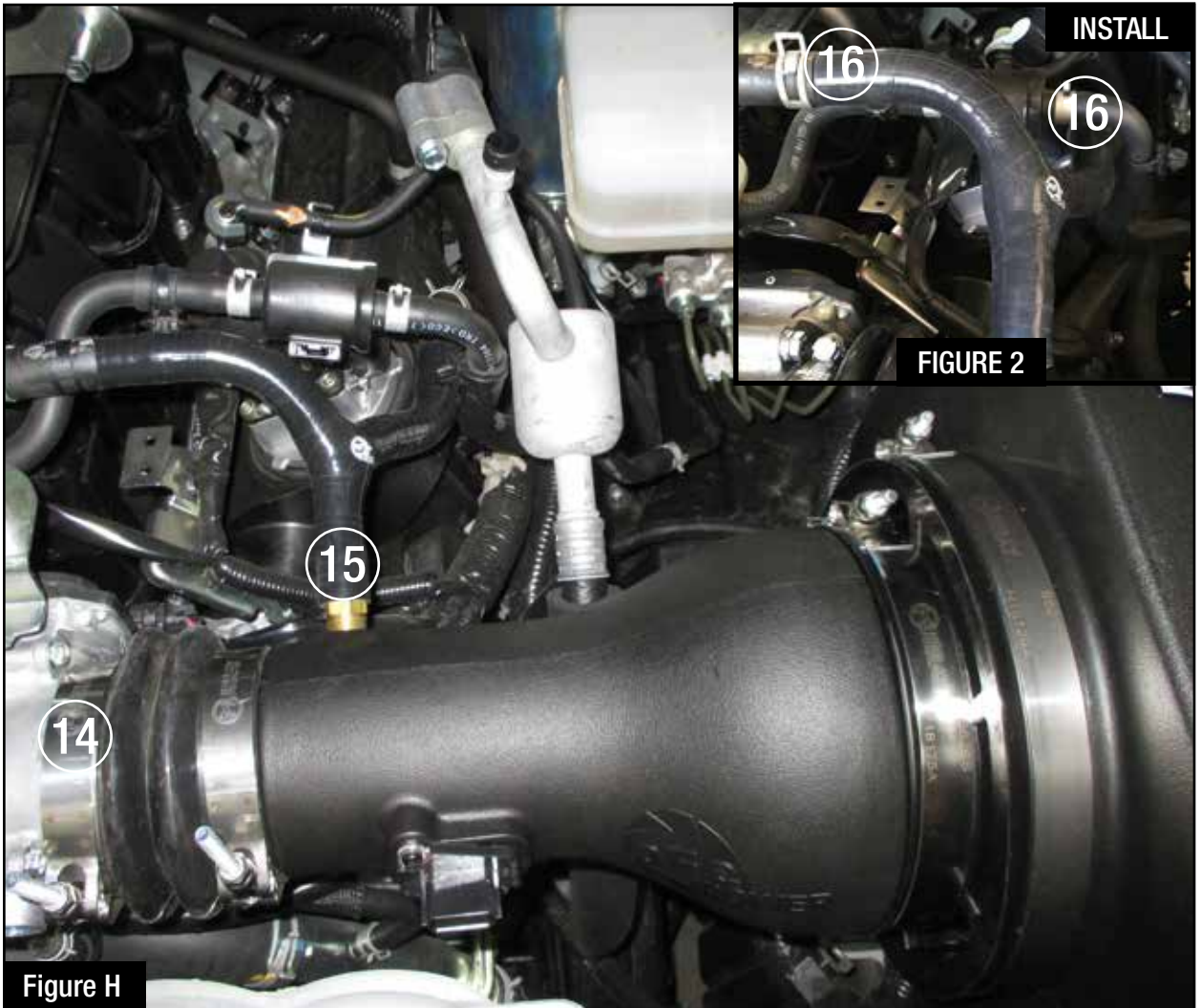

Figure G

**Refer to Figure G for Steps 15-16**

Step 15: Remove the MAF sensor from the factory intake and transfer to the aFe POWER intake tube, using the two (2x) supplied screws (12).

Step 16: Install the supplied brass fitting into the aFe POWER intake tube (13).



### **Refer to Figure H for Steps 17-20**

- Step 17: Install the supplied coupling into the vehicle. Tighten the clamp at the throttle body (14), but do not tighten the other clamp.
- Step 18: Install the aFe POWER intake tube into the vehicle. Orient the tube to have the logo face the front bumper cover and brass fitting face the firewall.
- Step 19: Install the provided silicone hose adaptor. Place the end with no fitting over the brass insert from Step 16 (15), as shown in Figure 2.
- Step 20: Install the remaining two (2x) ends of the adaptor to the factory CCV hoses (16) and reposition the factory spring clamps.

**Figure I****Refer to Figure I for Steps 21-24**

- Step 21: Adjust the tube to sit comfortably between the air filter, coupling, and crankcase hoses. Tighten all the clamps.
- Step 22: Connect the MAF harness to the MAF sensor (17).
- Step 23: Re-install the engine cover (18).
- Step 24: Verify all connections are secured. Your installation is now complete. Thank you for choosing aFe POWER!

**NOTE: Check all bolts, clamps, and connectors after 100-200 miles.**

Page left blank intentionally



Pro DRY S Air Filter



P/N: 21-91059

Pro 5R Air Filter



P/N: 24-91059

Pro DRY S Restore Kit



P/N: 90-59999

Blue Squeeze Restore Kit



P/N: 90-50501

Pre-Filter



P/N: 28-10273

Dynamic Air Scoop



P/N: 50-70034S

SPRINT BOOSTER V3



P/N: 77-16102

To purchase any of the items above, view airflow charts, dyno graphs, photos, and video; please go to [aFepower.com](http://aFepower.com).

# Warranty

## General Terms:

- aFe warrants their products to be free from manufacturer's defects due to workmanship and material.
- This warranty applies only to the original purchaser of the product and is non-transferrable.
- Proof of purchase of the aFe product is required for all warranty claims.
- Warranty is valid provided aFe instructions for installation and/or cleaning were properly followed.
- Proper maintenance with regular inspections of product is required to insure warranty coverage.
- Damage due to improper installation, abuse, unauthorized repair or alteration is not warranted.
- Incidental or consequential damages or cost, including installation and removal of part, incurred due to failure of aFe product is not covered under this warranty.
- All warranty is limited to the repair and/or replacement of the aFe part. To request Return Goods Authorization ("RGA"), email [RGA@afepower.com](mailto:RGA@afepower.com) or call (951)493-7100. Upon receipt of the RGA, you must return the product to the address provided in the RGA, freight prepaid and accompanied with a dated proof of purchase and the RGA. Upon receipt of the defective product and upon verification of proof of purchase, aFe will either repair or replace the defective product within a reasonable time, not to exceed thirty days.

Product Category	P/N Prefix	Warranty duration
Direct OE Replacement Filters	10, 11, 30, 31, 71, 73	Life of the vehicle
Racing Filters	18	1 year
Universal	21, 23, 24, 72, TF	2 years
Air Intake Systems	50, 51, 53, 54, 55, 56, 57, 75, TA, TM, TR	2 years
Exhaust Systems	49	2 years
Intercoolers & Intercooler Tubes	46-2	2 years
Intake Manifolds	46-1	2 years
Differential Cover	46-7	Life of the vehicle
Exhaust Manifolds	46	2 years
Throttle Body Spacers	46-3	2 years
Turbochargers	46-6	2 years*
Fluid Filters	44	90 days
Pre-Filters	28	2 years
Heavy Duty OE Replacement	70	2 years
PowerSports OE Replacement	81, 87	2 years
PowerSports Intake Systems	85	2 years

No other warranty expressed or implied applies nor is any person or advanced FLOW engineering authorized to assume any other warranty. Some States do not allow the exclusion or limitation of incidental or consequential damages or do not allow limitations on how long an implied warranty lasts, so the above limitations or exclusions may not apply to you. This warranty gives you specific legal rights, and you may also have other rights which vary from State to State.

\*See turbocharger warranty for more info



**advanced FLOW engineering, inc.**  
252 Granite Street Corona, CA 92879  
TEL: 951.493.7100 • TECH: 951.493.7134  
E-Mail: [Tech@aFepower.com](mailto:Tech@aFepower.com)