

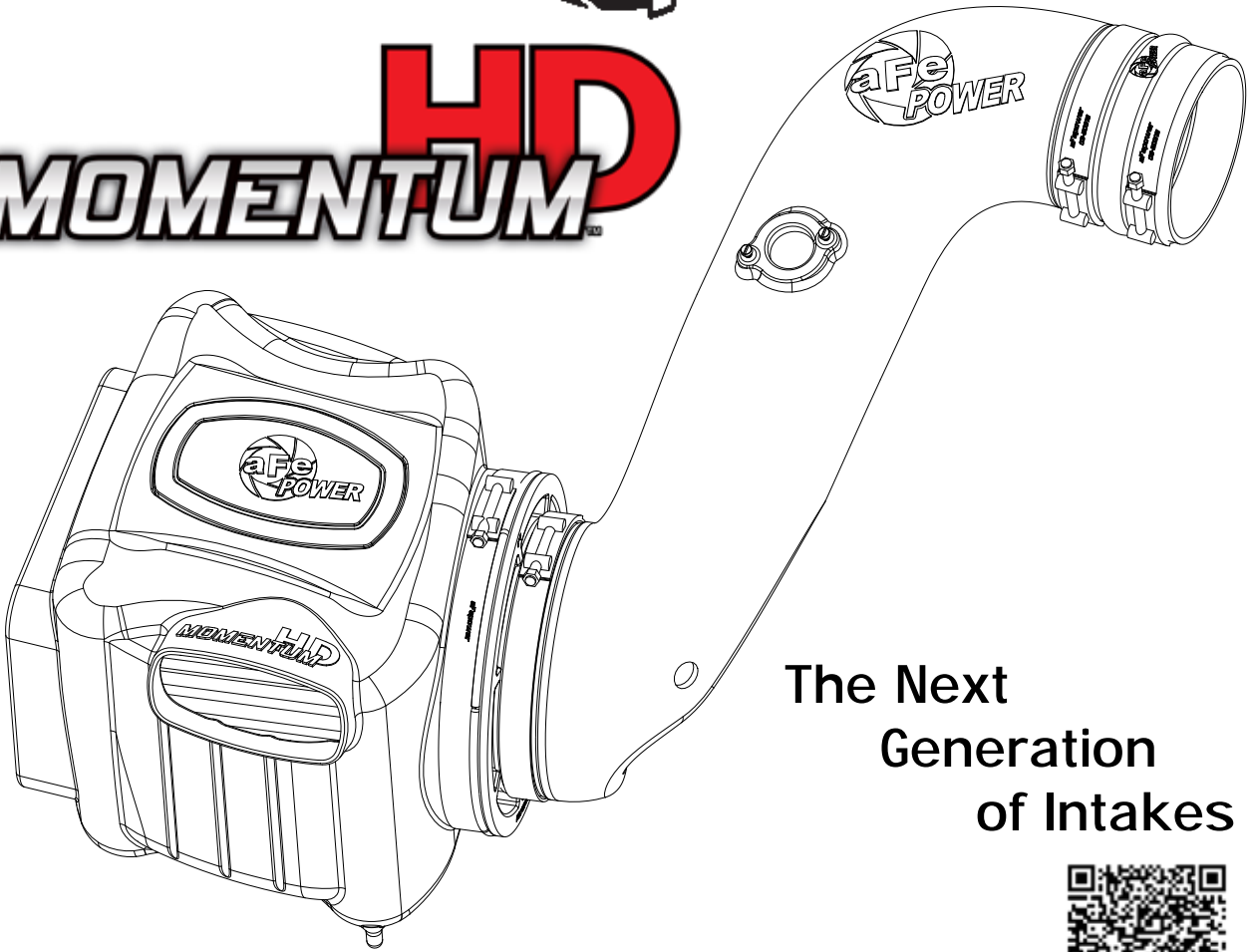

HD
MOMENTUM™



The Next
Generation
of Intakes



advanced FLOW engineering Momentum Air Intake

Instruction Manual P/N: 50-74003/51-74003/54-74003/75-74003

Make: **GM** Model: **Silverado/Sierra HD** Year: **2006-2007** Engine: **V8-6.6L (td) LLY/LBZ**



- Please read the entire instruction manual before proceeding.
- Ensure all components listed are present.
- If you are missing any of the components, call technical support at 951-493-7100 or e-mail tech@afepower.com.
- Ensure you have all necessary tools before proceeding.
- Do not attempt to work on your vehicle when the engine is hot.
- Disconnect both the negative battery terminal before proceeding.
- Retain factory parts for future use.

Label	Qty.	Description	Part Number
A	1	Plug, Urethane	05-01202
B	1	Seal Trim - 26"	05-00072
C	1	Housing	05-74003B2-S
D	1	Clamp, T-bolt (8-5/16")	03-50267
E1	1	PRO 5R (Blue Media)	24-91059
E2	1	PRO DRY S (Grey Media)	21-91059
E3	1	PRO-GUARD 7 (Yellow Media)	72-91059
E4	1	PRO 10R (Blue Media)	20-91059
F	1	Tube	05-74003B1
G	2	Screw, M4	03-50034
H	2	Clamp, T-bolt (4-7/16")	03-50319
I	1	Coupling, Silicone Hump	05-01201
J	1	T20 Torx Bit	03-50066

Installation will require the following tools:
 8mm Nut Driver, Flat Head Screw driver, 10mm Socket, Ratchet and Extension.

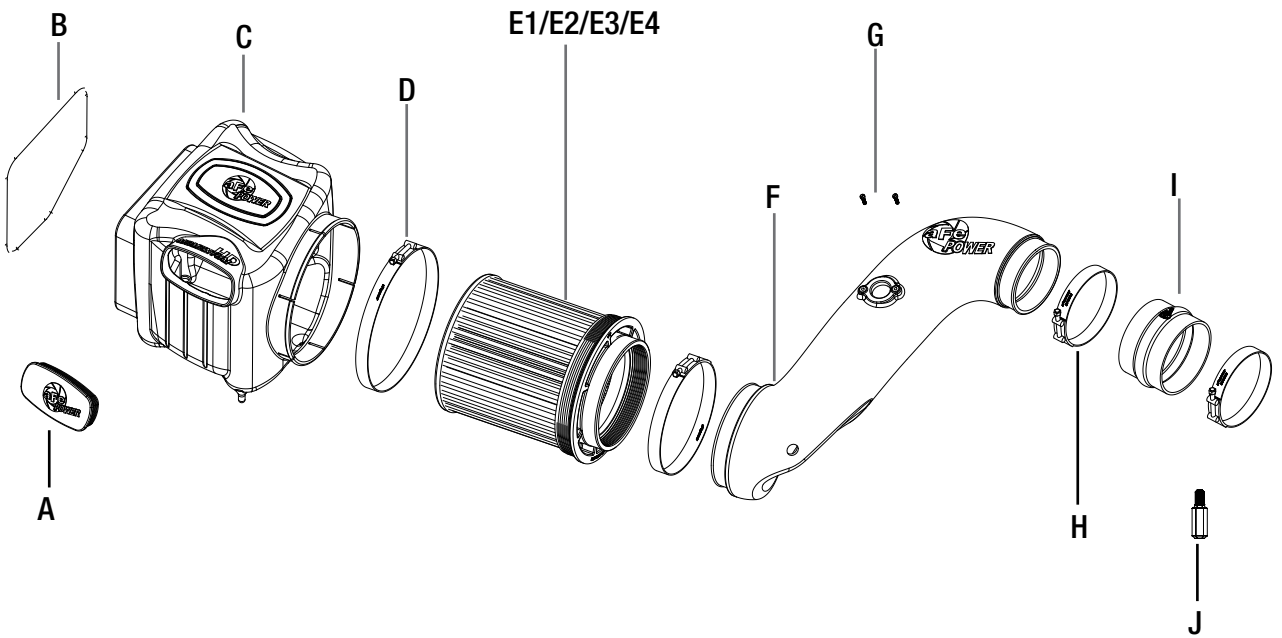



Refer to Figure A for steps 1-4

Step 1: Disconnect both batteries.

Step 2: Disconnect Mass Air Flow sensor (MAF) 1 .

Step 3: Loosen all intake tube clamps using a 8mm nut driver.

Step 4: Remove the factory intake tube and air box out of the vehicle. (Use an upward pull to release the air box from its mounting grommets)



Figure B

Refer to Figure B for step 6

Step 5: Clean the filter flange from release agent before installing the filter into the housing.

Step 6: Slide the air filter (E) into the air box (C). Install supplied T-bolt clamps (D) & (E).

(Do not tighten clamps at this time)

IMPORTANT: Prior to installation of T-bolt clamp, we recommend that you stretch the T-bolt clamps by installing it in its intended position and tightening.



Figure C

Refer to Figure C for steps 7 & 8

Step 7: Install the trim seal **B** on the edge of the Momentum HD air box.

Step 8: Remove the retaining plug **2** from the factory air box and install on the Momentum HD air box.

INSTALL



Refer to Figure D for step 10

Step 10: Install the Momentum HD air box into the vehicle. Firmly push down into the factory mounting grommets.

Figure E
Refer to Figure E for steps 11-15

Step 11: Remove the MAF sensor 3 from the factory intake tube using T-20 torx bit.

Step 12: Remove the filter minder 4 and the grommet it sits in from the factory air box.

Step 13: Install the MAF sensor in the Momentum intake tube F using supplied screws G.

Step 14: Install the factory grommet for the filter minder into the Momentum HD intake tube.

Firmly push the filter minder into the grommet on the intake tube to install it.

Step 15: Install the furnished silicone hump coupler I and the T-bolt clamps H on the Momentum HD intake tube. (Do not tighten clamps at this time)



Figure F

Refer to Figure F for steps 16 & 17

Step 16: Install the Momentum HD intake tube into the vehicle. Slide the coupling on to the turbo inlet first. Then rotate the tube down and slide it into the filter.

Step 17: Tighten all the T-bolt clamps.



Refer to Figure G for steps 18-20

Step 18: Reconnect the MAF sensor.

Step 19: Check all the components are tight and secured.

Step 20: Reconnect the batteries. Your installation is now complete.

Use the furnished plug (B) to close off the front auxiliary air inlet to completely seal the airbox.

NOTE: Retighten all connections after approximately 100-200 miles.

Place enclosed CARB EO sticker on or near the device on a smooth, clean surface.

EO identification label is required to pass the smog inspection.

Page left blank intentionally



Page left blank intentionally

Page left blank intentionally



Air Filter



PRO 10R P/N: 20-91059
PRO DRY S P/N: 21-91059
PRO 5R P/N: 24-91059
PRO GUARD 7 P/N: 72-91059

Pre-Filter



P/N: 28-10273

Blue Aerosol Restore Kit



P/N: 90-50001

Blue Squeeze Restore Kit



P/N: 90-50501

aFe Power Diesel T-Shirt



P/N: 40-30222 (L)
P/N: 40-30223 (XL)
P/N: 40-30224 (2XL)
P/N: 40-30225 (3XL)

aFe Power Hat



P/N: 40-10114 (S/M)
P/N: 40-10115 (L/XL)

aFe Power Ladies Hat



P/N: 40-10112

aFe Power Backpack



P/N: 40-33203



SAVE \$25
ON A REPLACEMENT
MOMENTUM
AIR FILTER. TO RECEIVE YOUR DISCOUNT PLEASE CALL
888.901.7693

To purchase any of the items above, view airflow charts, dyno graphs, photos, and video; please go to aFepower.com.

Warranty

General Terms:

- aFe warrants their products to be free from manufacturer's defects due to workmanship and material.
- This warranty applies only to the original purchaser of the product and is non-transferrable.
- Proof of purchase of the aFe product is required for all warranty claims.
- Warranty is valid provided aFe instructions for installation and/or cleaning were properly followed.
- Proper maintenance with regular inspections of product is required to insure warranty coverage.
- Damage due to improper installation, abuse, unauthorized repair or alteration is not warranted.
- Incidental or consequential damages or cost, including installation and removal of part, incurred due to failure of aFe product is not covered under this warranty.
- All warranty is limited to the repair and/or replacement of the aFe part. To request Return Goods Authorization ("RGA"), email RGA@afepower.com or call (951)493-7100. Upon receipt of the RGA, you must return the product to the address provided in the RGA, freight prepaid and accompanied with a dated proof of purchase and the RGA. Upon receipt of the defective product and upon verification of proof of purchase, aFe will either repair or replace the defective product within a reasonable time, not to exceed thirty days.

Product Category	P/N Prefix	Warranty duration
Direct OE Replacement Filters	10, 11, 30, 31, 71, 73	Life of the vehicle
Racing Filters	18	1 year
Universal	21, 24, 72	2 years
Air Intake Systems	50, 51, 54, 55, 75	2 years
Exhaust Systems	49	2 years
Intercoolers & Intercooler Tubes	46-2	2 years
Intake Manifolds	46-1	2 years
Differential Cover	46-7	Life of the vehicle
Exhaust Manifolds	46	2 years
Throttle Body Spacers	46-3	2 years
Fluid Filters	44	90 days
Pre-Filters	28	2 years
Heavy Duty OE Replacement	70	2 years
PowerSports OE Replacement	81, 87	2 years
PowerSports Intake Systems	85	2 years

No other warranty expressed or implied applies nor is any person or advanced FLOW engineering authorized to assume any other warranty. Some States do not allow the exclusion or limitation of incidental or consequential damages or do not allow limitations on how long an implied warranty lasts, so the above limitations or exclusions may not apply to you. This warranty gives you specific legal rights, and you may also have other rights which vary from State to State.



advanced FLOW engineering, inc.

252 Granite Street Corona, CA 92879

TEL: 951.493.7155 • TECH: 951.493.7100

E-Mail: Tech@aFepower.com