

advanced FLOW engineering Quantum Air Intake
Instruction Manual P/N: 53-10001D / 53-10001R

Make: **Dodge** Model: **RAM 2500/3500** Year: **1994-2002** Engine: **L6-5.9L (td) Cummins**



- Please read the entire instruction manual before proceeding.
- Ensure all components listed are present.
- If you are missing any of the components, call customer support at 951-493-7100 or e-mail at tech@afepower.com.
- Ensure you have all necessary tools before proceeding.
- Do not attempt to work on your vehicle when the engine is hot.
- Disconnect the negative battery terminal before proceeding.
- Retain factory parts for future use.

Label	Qty.	Description	Part Number
A1	1	Air Filter (Pro 5R)	R23-91129
A2	1	Air Filter (Pro DRY S)	R21-90098
B	1	Housing	05-52001B2
C	1	Tube	05-52001B1
D	1	Grommet	03-50033
E	1	Cap	03-50103
F	2	Clamp, #064	03-50006
G	1	Coupling, Silicone Hump	05-01332
H	1	Seal Trim (18")	05-00072
I	1	Clamp, #072	03-50010
J	1	Clamp, #080	03-50011
K	1	Coupling, Silicone Bellow	05-01457

Installation will require the following tools:

8mm Nut driver and Phillips #3 screwdriver.

Note: Legal in California for use on race vehicles only. The use of this device on vehicles used on public streets or highways is strictly prohibited in California and others states that have adopted California emission regulations.

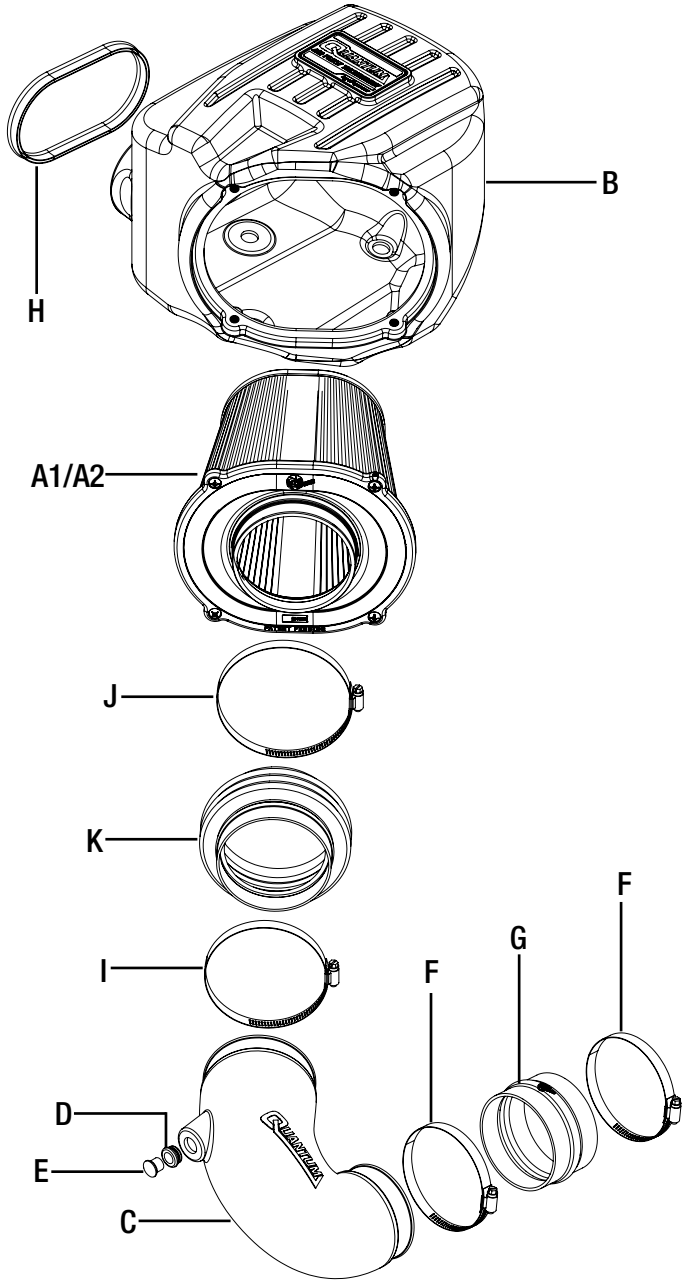

**Figure A****Refer to Figure A for Step 1**

Step 1: Use an 8mm nut driver to loosen the OE clamps (1) at the turbo and the airbox. Remove the OE intake tube (2).



Figure B

Refer to Figure B for Step 2

Step 2: Un-clip the upper half of the airbox and remove upper half and air filter.



Refer to Figure C for Step 3

Step 3: Remove the lower half of the airbox (3) by pulling up to release airbox from its mounting grommets (4).

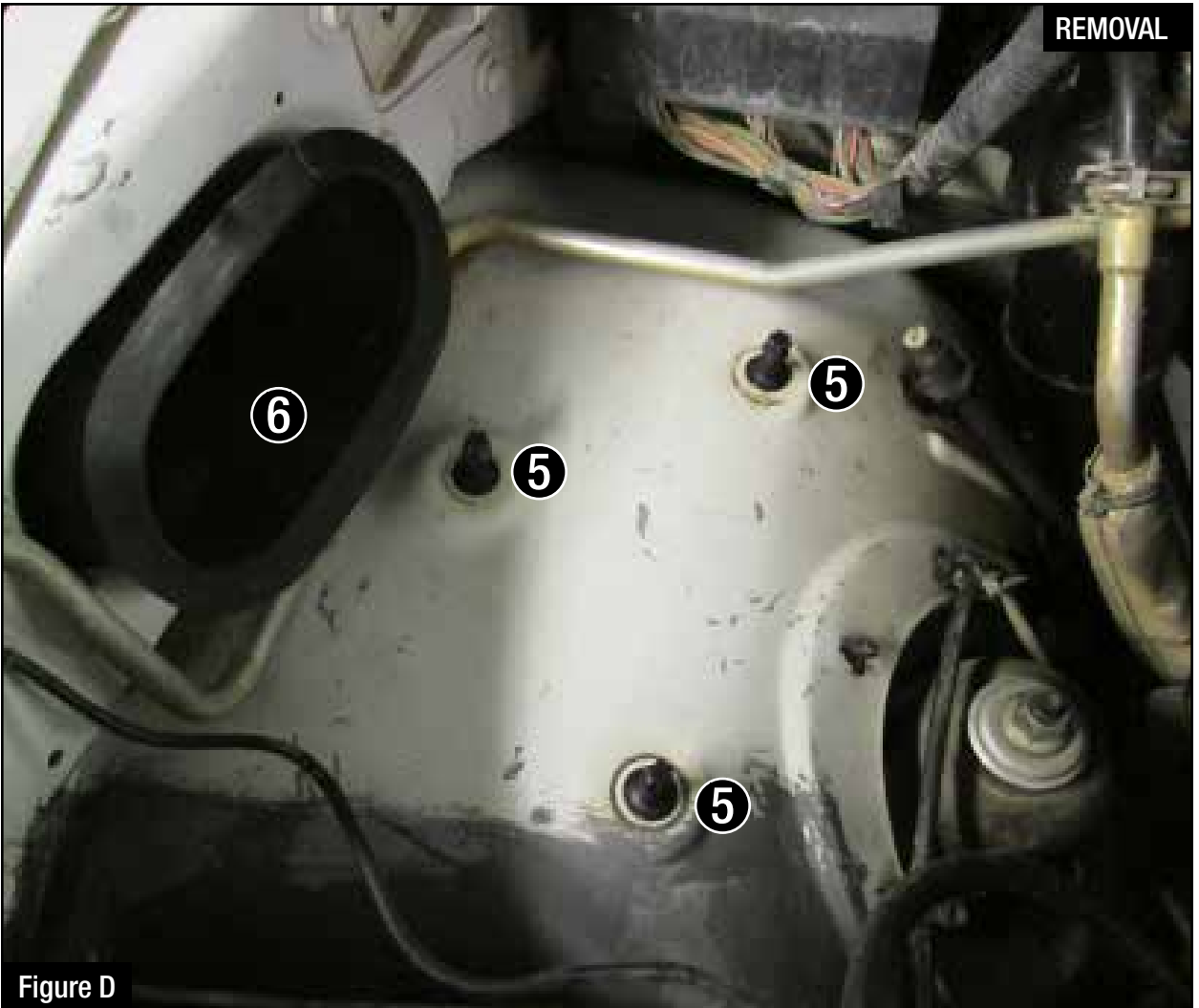

Figure D

Refer to Figure D for Step 4

Step 4: Make sure plastic inserts (5) are still on the mounting pins. If they pulled out and are stuck in the lower half of the airbox grommet, remove them and insert them back on the mounting pins. Remove the plastic air duct (6) that goes through the fender if equipped.



Refer to Figure E for Step 5

Step 5: Remove all three grommets (7) from the lower half of the airbox and install them onto the aFe airbox.



Figure F

Refer to Figure F for Step 6

Step 6: Install the trim seal (8) on the opening of the aFe airbox.

**Figure G****Refer to Figure G for Steps 7-8**

Step 7: Slide the aFe filter into the aFe housing. Install the aFe filter using a #3 Phillips screwdriver. Tighten all (x4) screws.

Step 8: Install the supplied bellows coupler (9) onto the air filter using the supplied #80 clamp (10). Tighten the clamp.



Figure H

Refer to Figure H for Step 9

Step 9: Install the housing assembly into the vehicle by pushing down into the plastic pins.

Make sure pins are completely through the mounting grommets.



Figure I

Refer to Figure I for Step 10

Step 10: Install the aFe coupler (11) onto the turbo using the supplied #064 clamp (12). Tighten the clamp.

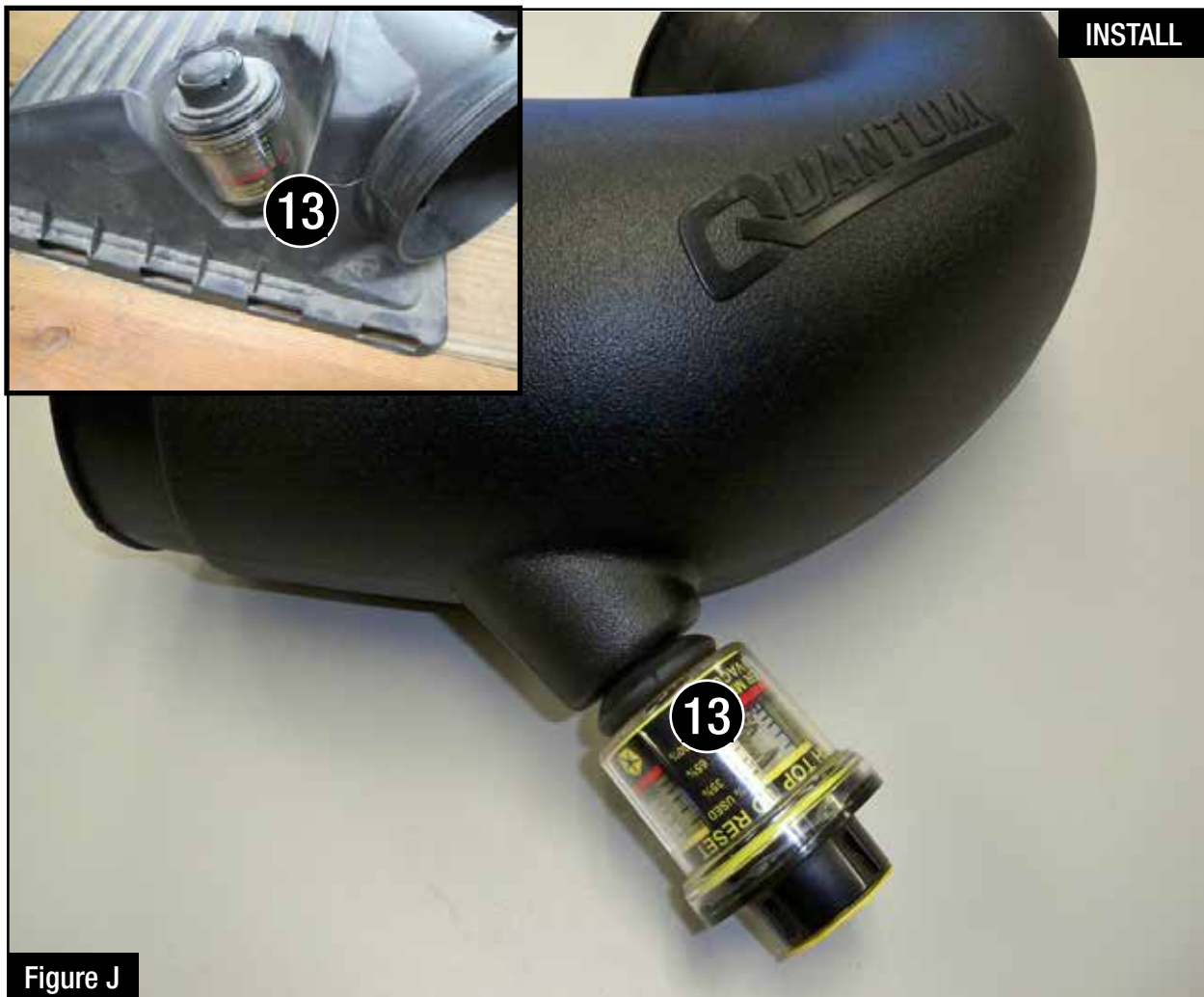

Figure J

Refer to Figure F for Step 11

Step 11: Remove the filter minder and grommet (13) from the upper half of the stock air box. Install the grommet into the aFe intake tube and then push in the filter minder. If you choose not to use the filter minder, just plug off the hole with the provided grommet and cap.

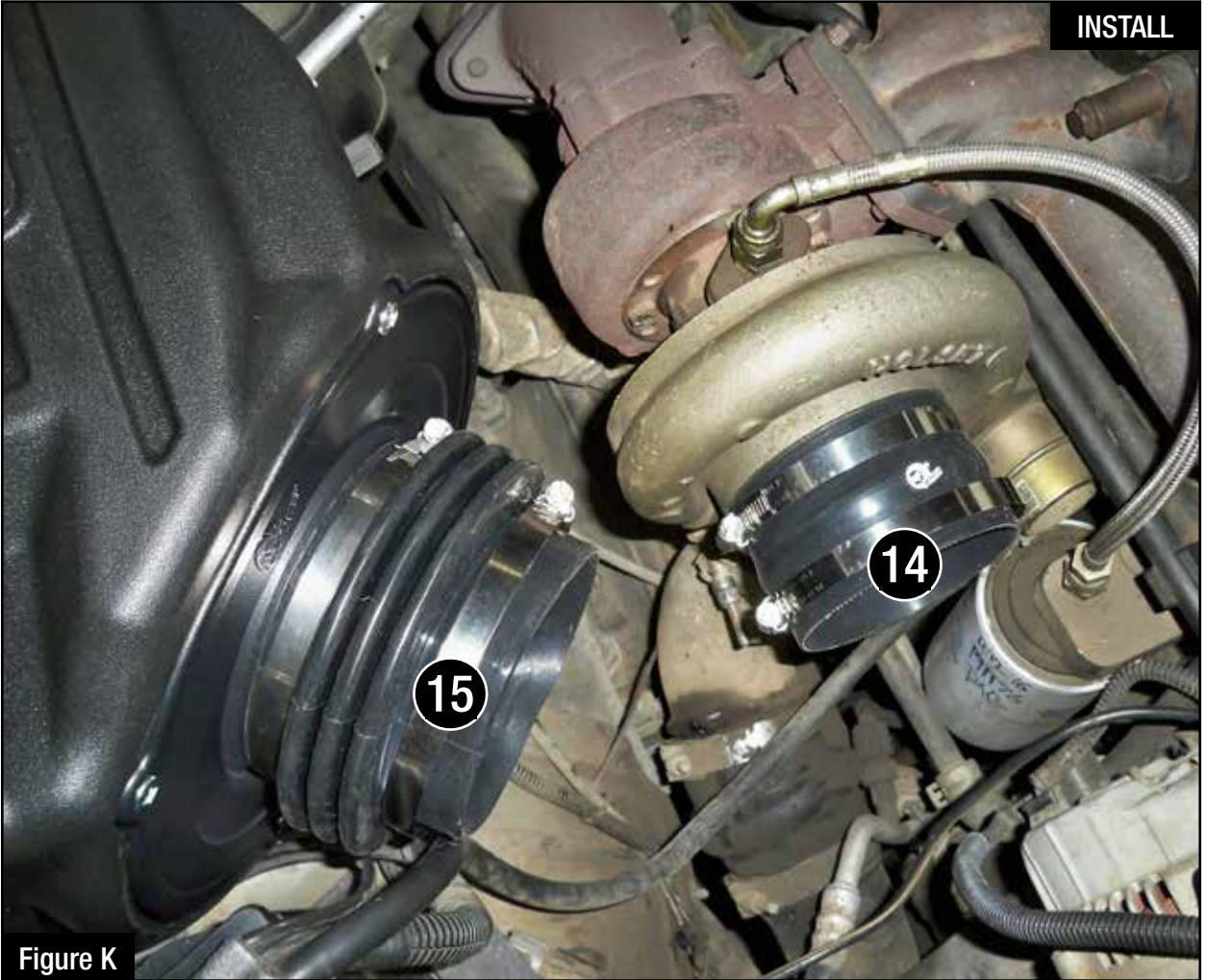

Figure K

Refer to Figure K for Step 12

Step 12: Install the provided #064 clamp (14) onto the coupler at the turbo and #072 clamp (15) onto the filter coupler.



Figure L

Refer to Figure L for Step 13

Step 13: Slide the aFe intake tube into the coupler at the filter, then install the intake tube into the coupler at the turbo. Tighten all clamps with an 8mm nut driver. Check all the components are tight and secure. Your installation is now complete.

NOTE: Check all bolts, clamps, and connectors after 100-200 miles.



Page left blank intentionally

Page left blank intentionally



Pro DRY S Air Filter



P/N: 21-90098

Pro 5R Air Filter



P/N: 23-91129

Blue Squeeze Restore Kit



P/N: 90-50501

Pro DRY S Restore Kit



P/N: 90-59999

Intercooler w/ Tubes



P/N: 46-20062 (GT Series)
46-21062-B (Street Series)

Exhaust Ported Manifold



P/N: 46-40044 ('94-'98)
46-40034 ('98.5-'02)

Intake Manifold



P/N: 46-10051 ('94-'98)
46-10021 ('98.5-'02)

Stainless Steel
Exhaust Manifold



P/N: 46-32019 (w/ T4 Flange)
46-32020 (w/ T3 Flange)

TB-Back Exhaust System



P/N: 49-42033-P (Pol. Tip)
49-42033-B (Blk. Tip)

Transmission Pan Cover



P/N: 46-70052

Fuel Filter



P/N: 44-FF004

Differential Cover w/ Oil



P/N: 46-70032-WL
46-70032 (Blk./Mach)
46-70030 (RAW)

To purchase any of the items above, view airflow charts, dyno graphs, photos, and video; please go to aFepower.com.

Warranty

General Terms:

- aFe warrants their products to be free from manufacturer's defects due to workmanship and material.
- This warranty applies only to the original purchaser of the product and is non-transferrable.
- Proof of purchase of the aFe product is required for all warranty claims.
- Warranty is valid provided aFe instructions for installation and/or cleaning were properly followed.
- Proper maintenance with regular inspections of product is required to insure warranty coverage.
- Damage due to improper installation, abuse, unauthorized repair or alteration is not warranted.
- Incidental or consequential damages or cost, including installation and removal of part, incurred due to failure of aFe product is not covered under this warranty.
- All warranty is limited to the repair and/or replacement of the aFe part. To request Return Goods Authorization ("RGA"), email RGA@afepower.com or call (951)493-7100. Upon receipt of the RGA, you must return the product to the address provided in the RGA, freight prepaid and accompanied with a dated proof of purchase and the RGA. Upon receipt of the defective product and upon verification of proof of purchase, aFe will either repair or replace the defective product within a reasonable time, not to exceed thirty days.

Product Category	P/N Prefix	Warranty duration
Direct OE Replacement Filters	10, 11, 30, 31, 71, 73	Life of the vehicle
Racing Filters	18	1 year
Universal	21, 24, 72	2 years
Air Intake Systems	50, 51, 54, 55, 75	2 years
Exhaust Systems	49	2 years
Intercoolers & Intercooler Tubes	46-2	2 years
Intake Manifolds	46-1	2 years
Differential Cover	46-7	Life of the vehicle
Exhaust Manifolds	46	2 years
Throttle Body Spacers	46-3	2 years
Fluid Filters	44	90 days
Pre-Filters	28	2 years
Heavy Duty OE Replacement	70	2 years
PowerSports OE Replacement	81, 87	2 years
PowerSports Intake Systems	85	2 years

No other warranty expressed or implied applies nor is any person or advanced FLOW engineering authorized to assume any other warranty. Some States do not allow the exclusion or limitation of incidental or consequential damages or do not allow limitations on how long an implied warranty lasts, so the above limitations or exclusions may not apply to you. This warranty gives you specific legal rights, and you may also have other rights which vary from State to State.



advanced FLOW engineering, inc.
252 Granite Street Corona, CA 92879
TEL: 951.493.7100 • TECH: 951.493.7134
E-Mail: Tech@aFepower.com