

advanced FLOW engineering Quantum Air Intake

Instruction Manual P/N: 53-10005D / 53-10005R

Make: **Chevrolet** Model: **Silverado HD** Year: **2007.5-2010** Engine: **V8-6.6L Duramax (LMM)**

Make: **GMC** Model: **Sierra HD** Year: **2007.5-2010** Engine: **V8-6.6L Duramax (LMM)**

Note: **Includes Denali Trim.**



- Please read the entire instruction manual before proceeding.
- Ensure all components listed are present.
- If you are missing any of the components, call customer support at 951-493-7100.
- Ensure you have all necessary tools before proceeding.
- Do not attempt to work on your vehicle when the engine is hot.
- Disconnect the negative battery terminal before proceeding.
- Retain factory parts for future use.

Label	Qty.	Description	Part Number
A1	1	Air Filter (Pro DRY S)	21-90098
A2	1	Air Filter (Pro 5R)	23-91129
B	1	Tube	05-54004B1
C	1	Housing	05-54006B2
D	1	Filter, Elbow	05-54004B3
E	1	Coupling, Filter Adaptor	05-01476
F	2	Clamp, #072	03-50010
G	1	Seal Trim 7/16" (26")	05-00072
H	2	Screws, Torx M4	03-50491
I	1	Grommet, Ait Temp Sensor	03-50033
J	1	Cap: 1/2"	03-50103
K	1	Clamp, #088	03-50005
L	1	Coupling, Silicone Bellow	05-01456
M	1	Coupling, Silicone Hump	05-01201
N	2	Clamp, #080	03-50011

Installation will require the following tools:

8mm Nut driver, T20 torx bit or driver, Phillips #3 screwdriver.

Note: Legal in California for use on race vehicles only. The use of this device on vehicles used on public streets or highways is strictly prohibited in California and others states that have adopted California emission regulations.

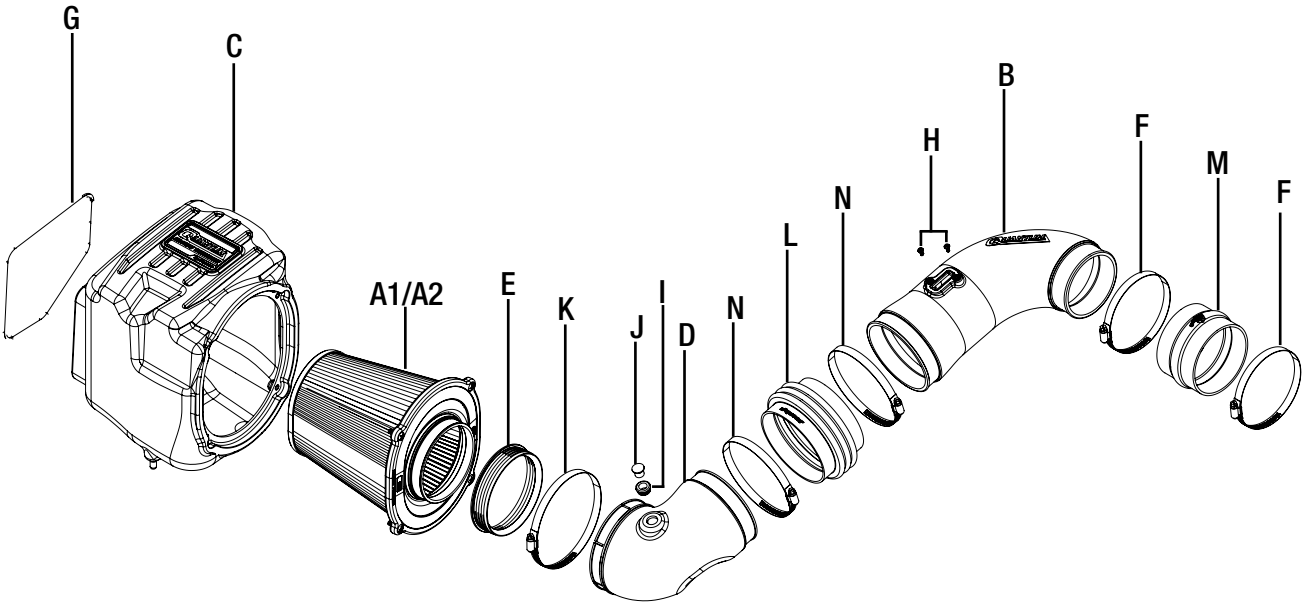



Refer to Figure A for Steps 1-4

- Step 1: Disconnect the Mass Air Flow sensor. ①
- Step 2: Using an 8mm nut driver, loosen the clamps ② from the intake tube.
- Step 3: Remove the factory intake tube. ③
- Step 4: Remove the factory airbox ④ out of the vehicle. (Use an upward pull to release the retaining plug).

**Figure B****Refer to Figure B for Steps 5-6**

Step 5: Slide the aFe filter into the aFe housing. Install the aFe filter using a #3 Phillips screwdriver. Tighten all (x4) screws.

Step 6: Install the supplied filter coupling ⑤ onto the air filter.



Figure C

Refer to Figure C for Steps 7-8

Step 7: Remove the retaining plug (6) from the bottom of the factory airbox and transfer it to the aFe housing.

Step 8: Install the supplied trim seal (7) on the opening of the aFe housing.



REMOVAL



Figure D

Refer to Figure D for Step 9

Step 9: On the mounting plate, move the front right mounting grommet (8) to the hole on the left. Install the aFe housing assembly into the vehicle. Firmly push it into the factory mounting grommets.

**Figure E****Refer to Figure E for Steps 10-11**

Step 10: Remove the filter minder and grommet (9) from factory airbox. Install the grommet into the aFe elbow tube and then push in the filter minder. If you choose not to use the filter minder, just plug off the hole with the supplied grommet and cap.

Step 11: Place the supplied #088 (10) clamp onto the elbow tube slot with cuts section.



Figure F

Refer to Figure F for Steps 12-13

Step 12: Install the aFe elbow tube assembly onto the filter coupling. Align elbow tube but do not tighten the clamp.

Step 13: Place the supplied #080 (11) clamp and bellows coupling (12) onto the aFe elbow tube.



Refer to Figure G for Steps 14-15

Step 14: Slide the supplied hump coupling (13) and #072 clamp (14) over the turbo inlet.

Step 15: Place the other supplied #072 (15) clamp over the hump coupling and #080 (16) clamp over the bellows couplings.



Figure H

Refer to Figure H for Steps 16-17

Step 16: Using a T-20 Torx driver, remove the MAF sensor (17) from the factory airbox.

Step 17: Install the MAF sensor into the aFe intake tube using the provided M4 screws and a T-20 Torx driver.

**Figure I****Refer to Figure I for Steps 18-20**

Step 18: Slide the aFe intake tube into the bellows coupling, then into the coupling at the turbo inlet.

Align tubes and clamps, then tighten all the clamps with an 8mm nut driver.

Step 19: Reconnect the MAF sensor. ⑱

Step 20: Check all the components are tight and secure. Your installation is now complete. Thank you for choosing aFe POWER.

NOTE: Check all bolts, clamps, and connectors after 100-200 miles.



Pro DRY S Air Filter



P/N: 21-90098

Pro 5R Air Filter



P/N: 23-91129

Pro DRY S Restore Kit



P/N: 90-59999

Blue Squeeze Restore Kit



P/N: 90-50501

Pre-Filter



P/N: 28-10423

Downpipe Back Exhaust



P/N: 49-04060 (No Tip)
49-04060NM (No Muffler)

Exhaust Manifolds



P/N: 46-40024

DPF-Back Exhaust



P/N: 49-44040-B (Blk. Tip)
49-44040-P (Pol. Tip)

Turbo Inlet Manifold



P/N: 46-60039-1

DFS PRO Fuel System



P/N: 42-24011

SCORCHER HD Module



P/N: 77-44006

Intercooler Hot-Side Tube



P/N: 46-20049

To purchase any of the items above, view airflow charts, dyno graphs, photos, and video; please go to aFepower.com.

Warranty

General Terms:

- aFe warrants their products to be free from manufacturer's defects due to workmanship and material.
- This warranty applies only to the original purchaser of the product and is non-transferrable.
- Proof of purchase of the aFe product is required for all warranty claims.
- Warranty is valid provided aFe instructions for installation and/or cleaning were properly followed.
- Proper maintenance with regular inspections of product is required to insure warranty coverage.
- Damage due to improper installation, abuse, unauthorized repair or alteration is not warranted.
- Incidental or consequential damages or cost, including installation and removal of part, incurred due to failure of aFe product is not covered under this warranty.
- All warranty is limited to the repair and/or replacement of the aFe part. To request Return Goods Authorization ("RGA"), email RGA@afepower.com or call (951)493-7100. Upon receipt of the RGA, you must return the product to the address provided in the RGA, freight prepaid and accompanied with a dated proof of purchase and the RGA. Upon receipt of the defective product and upon verification of proof of purchase, aFe will either repair or replace the defective product within a reasonable time, not to exceed thirty days.

Product Category	P/N Prefix	Warranty duration
Direct OE Replacement Filters	10, 11, 30, 31, 71, 73	Life of the vehicle
Racing Filters	18	1 year
Universal	21, 23, 24, 72	2 years
Air Intake Systems	50, 51, 53, 54, 55, 75, 56	2 years
Exhaust Systems	49	2 years
Intercoolers & Intercooler Tubes	46-2	2 years
Intake Manifolds	46-1	2 years
Differential Cover	46-7	Life of the vehicle
Exhaust Manifolds	46	2 years
Throttle Body Spacers	46-3	2 years
Fluid Filters	44	90 days
Pre-Filters	28	2 years
Heavy Duty OE Replacement	70	2 years
PowerSports OE Replacement	81, 87	2 years
PowerSports Intake Systems	85	2 years

No other warranty expressed or implied applies nor is any person or advanced FLOW engineering authorized to assume any other warranty. Some States do not allow the exclusion or limitation of incidental or consequential damages or do not allow limitations on how long an implied warranty lasts, so the above limitations or exclusions may not apply to you. This warranty gives you specific legal rights, and you may also have other rights which vary from State to State.

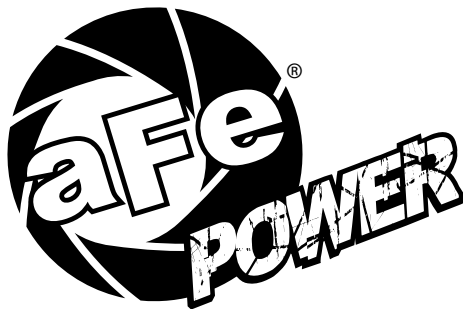

advanced FLOW engineering, inc.
252 Granite Street Corona, CA 92879
TEL: 951.493.7100 • TECH: 951.493.7134
E-Mail: Tech@aFepower.com