



INTAKE SYSTEMS FOR VEHICLES LISTED ARE 50 STATE LEGAL. SEE KNFILTERS.COM FOR CARB STATUS ON EACH PART FOR A SPECIFIC VEHICLE.

INSTALLATION INSTRUCTIONS

57-9034
TOYOTA
2010-19 4Runner
2010-14 FJ Cruiser
V6-4.0L

NOTE: This kit was not designed to fit vehicles with a body lift.

TOOLS NEEDED:

- flat blade screw driver
- phillips screw driver

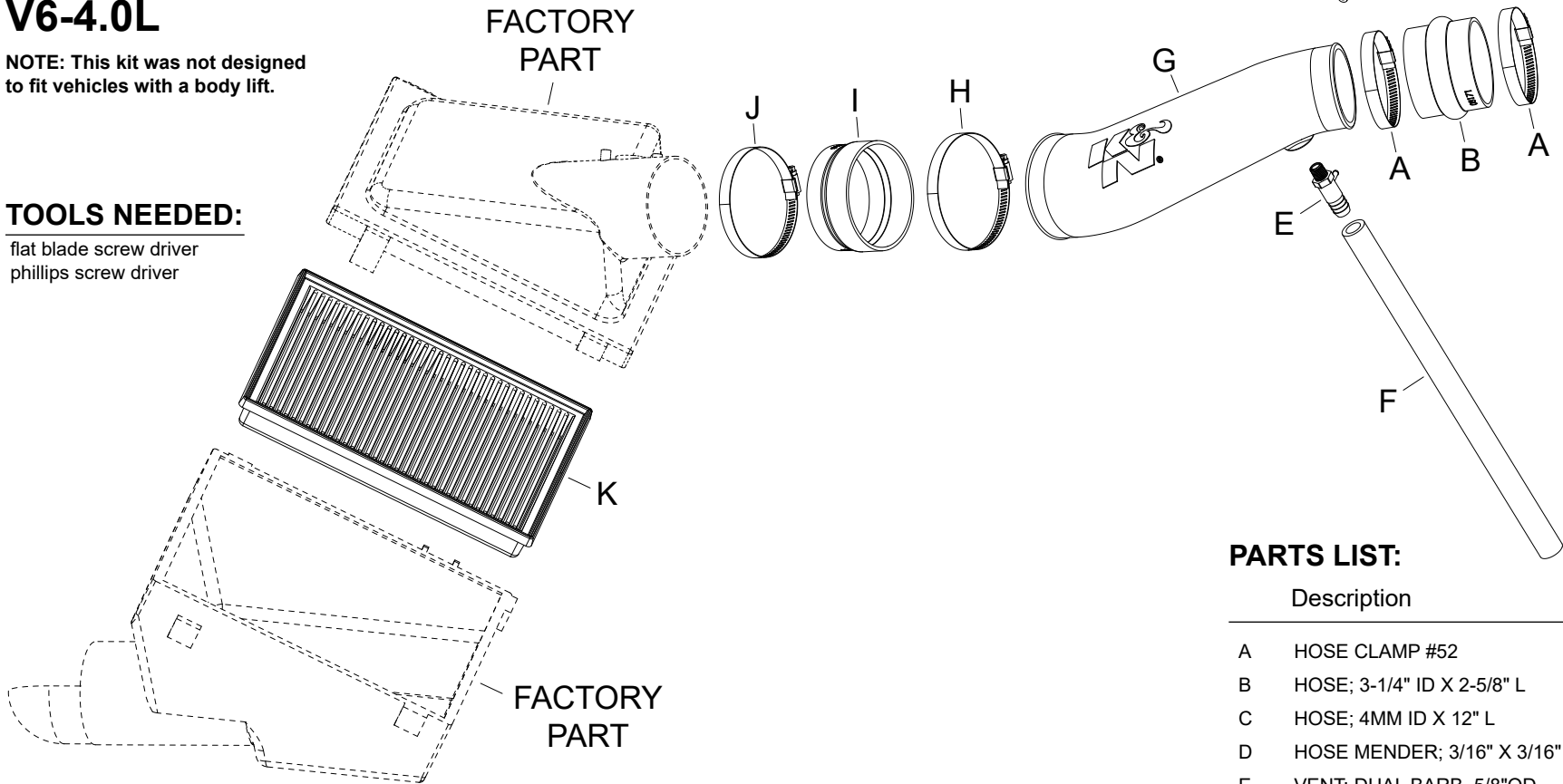

PARTS LIST:

	Description	Qty.	Part #
A	HOSE CLAMP #52	2	08610
B	HOSE; 3-1/4" ID X 2-5/8" L	1	08171
C	HOSE; 4MM ID X 12" L	1	08147
D	HOSE MENDER; 3/16" X 3/16"	1	08703
E	VENT; DUAL BARB, 5/8"OD	1	088018
F	HOSE; 5/8" ID X 16-1/2"	1	08482
G	INTAKE TUBE (LM)	1	087336A
H	HOSE CLAMP #64 STAINLESS	1	08645
I	HOSE; 4" TO 3-13/16" ID X 2"	1	08618
J	HOSE CLAMP #60 STAINLESS	1	08628
K	FILTER	1	33-2438

If you need any assistance please call 1-800-858-3333 to speak with a representative in our Customer Service Center before returning the product.

NOTE: FAILURE TO FOLLOW INSTALLATION INSTRUCTIONS AND NOT USING THE PROVIDED HARDWARE MAY DAMAGE THE INTAKE TUBE, THROTTLE BODY AND ENGINE.

TO START:

1. Turn off the ignition and disconnect the negative battery cable.
NOTE: Disconnecting the negative battery cable erases pre-programmed electronic memories. Write down all memory settings before disconnecting the negative battery cable. Some radios will require an anti-theft code to be entered after the battery is reconnected. The anti-theft code is typically supplied with your owner's manual. In the event your vehicles anti-theft code cannot be recovered, contact an authorized dealership to obtain your vehicles anti-theft code.



2. Lift up the decorative engine cover and remove it from the vehicle.



3. Release the spring clamp and then disconnect the crank case vent hose from the factory intake tube.
NOTE: Also disconnect the fuel pressure regulator vent hose, not pictured.



4. Remove the bolt which secures the intake plenum to the mounting bracket and unhook the mass air sensor wiring harness from the intake plenum.



5. Loosen the two hose clamps that secure the intake tube assembly to the throttle body and air filter housing.



6. Release the three air filter housing clips and then lift off the upper air filter housing and remove the intake tube assembly from the vehicle.
NOTE: K&N Engineering, Inc., recommends that customers do not discard factory air intake.



7. Remove the factory air filter and replace it with the provided K&N® air filter.



8. Install the provided combination vent fitting into the K&N® intake tube as shown.

NOTE: the small port of the fitting should be pointed towards the rear of the engine once the tube is installed.

NOTE: Plastic NPT fittings are easy to cross thread. Install the vent fitting "hand" tight, then turn it two complete turns with a wrench.



9. Install the provided coupler hoses onto the K&N® intake tube as shown and secure with the provided hose clamps.



10. Install the K&N® intake tube assembly onto the throttle body as shown but do not secure at this time.

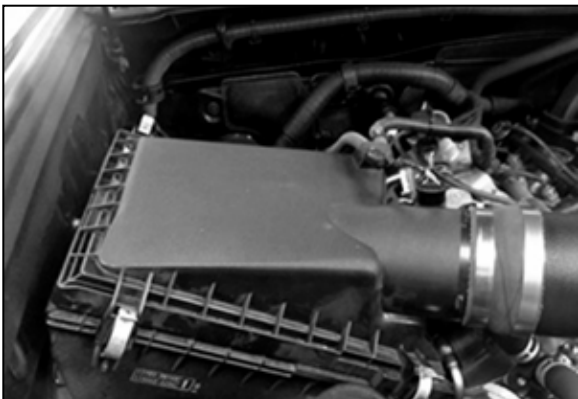

11. Reinstall the factory air filter housing and secure with the factory retaining clips.

NOTE: Insert the mass air sensor section of the housing into the coupling hose installed onto the K&N® intake tube as the housing is being installed.



12. Adjust the intake tube for best fit and then secure with the provide hose clamps.



13. Install the hose mender into the provided fuel pressure regulator hose as shown.



14. Connect the crank case vent hose to the fitting installed into the K&N® intake tube and secure with the factory spring clamp. Install the supplied fuel pressure regulator vent hose into the factory vent hose and then connect it to the small port of the fitting installed into the K&N® intake tube.



15. Reinstall the decorative engine cover.



15. Reconnect the vehicle's negative battery cable. Double check to make sure everything is tight and properly positioned before starting the vehicle.

16. The C.A.R.B. exemption sticker, (attached), must be visible under the hood so that an emissions inspector can see it when the vehicle is required to be tested for emissions. California requires testing every two years, other states may vary.

17. It will be necessary for all K&N® high flow intake systems to be checked periodically for realignment, clearance and tightening of all connections. Failure to follow the above instructions or proper maintenance may void warranty.

ROAD TESTING:

1. Start the engine with the transmission in neutral or park, and the parking brake engaged. Listen for air leaks or odd noises. For air leaks secure hoses and connections. For odd noises, find cause and repair before proceeding. This kit will function identically to the factory system except for being louder and much more responsive.

2. Test drive the vehicle. Listen for odd noises or rattles and fix as necessary.

3. If road test is fine, you can now enjoy the added power and performance from your kit.

4. K&N Engineering, Inc., requires cleaning the intake system's air filter element every 100,000 miles. When used in dusty or off-road environments, our filters will require cleaning more often. We recommend that you visually inspect your filter once every 25,000 miles to determine if the screen is still visible. When the screen is no longer visible some place on the filter element, it is time to clean it. To clean and re-oil, purchase our filter Recharger® service kit, part number 99-5050 or 99-5000 and follow the easy instructions.

INTAKE SYSTEMS FOR VEHICLES LISTED ARE 50 STATE LEGAL. SEE KNFILTERS.COM FOR CARB STATUS ON EACH PART FOR A SPECIFIC VEHICLE.