

***advanced FLOW engineering*** Turbo Inlet (with Takeda Intake)

**Instruction Manual** P/N: 59-20002

Make: Hyundai

Model: Veloster N

Year: 2019-2020

Engine: L4-2.0L(t)

(This part will only fit with Takeda Intake 56-70021R, 56-70021D, 56-10021R and 56-10021D)



- Please read the entire instruction manual before proceeding.
- Ensure all components listed are present.
- If you are missing any of the components, call customer support at 951-493-7185.
- Ensure you have all necessary tools before proceeding.
- Do not attempt to work on your vehicle when the engine is hot.
- Retain factory parts for future use.

Label	Qty.	Description	Part Number
A	1	Aluminum Adaptor, Turbo	05-01531
B	1	Silicone Coupling	05-01532
C	2	Clamp #048	03-50007

**Installation will require the following tools:**

8mm and 10mm socket, extension, ratchet, pliers and flat-head screwdriver

**Emissions Disclaimer:** This product is not currently CARB exempt and is not available for purchase in California or for use on any vehicle registered with the California Department of Motor Vehicles.

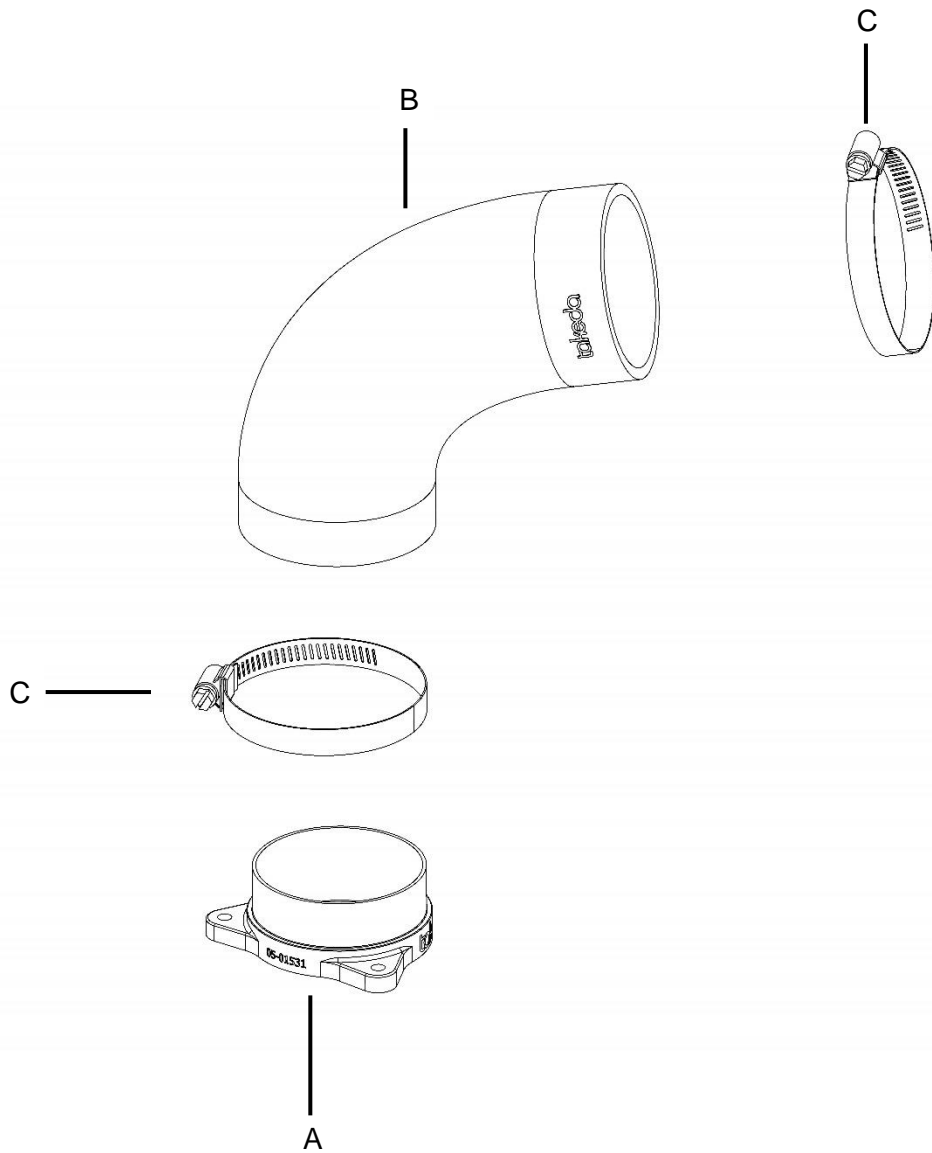

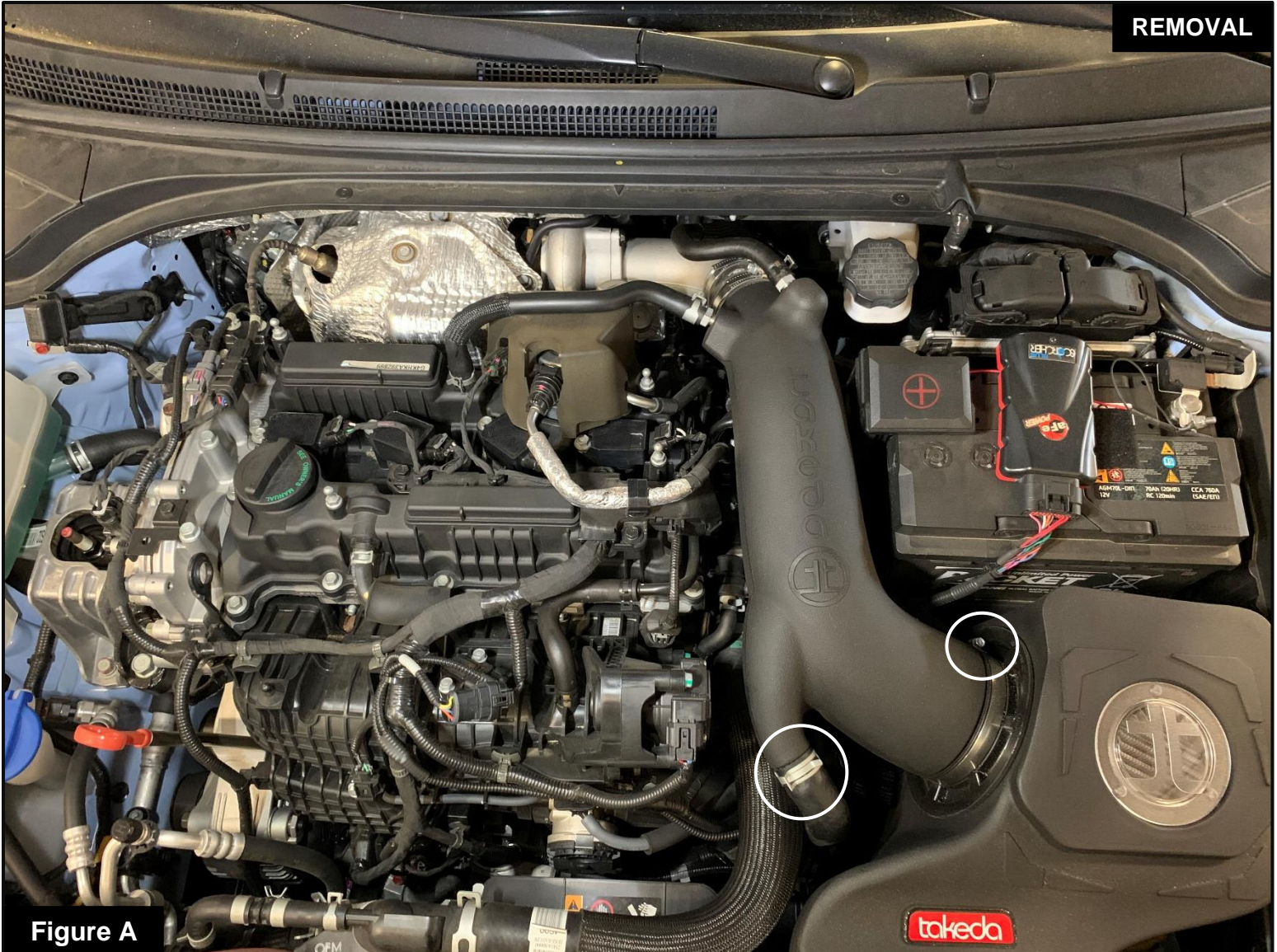
**Figure A****Refer to Figure A for Steps 1-3**

Step 1: Remove the engine cover by pulling upward on it.

Step 2: Using pliers, open the clamp securing the hose to the air intake tube, and then slide the clamp away from the intake tube. This clamp will be reused. Disconnect the rubber hose from the air intake tube.

Step 3: Loosen the clamp securing the Takeda intake tube to the Takeda air filter using a 8mm socket and ratchet or nut driver.



**Figure B****Refer to Figure B for Steps 4-6**

Step 4: Using pliers, open the clamps securing the small hoses to the air intake tube toward the firewall.

Slide the clamps away from the tube and disconnect the small rubber hoses from the intake tube. Those clamps will be reused.

Step 5: Loosen the clamp at the turbo inlet using an 8mm nut driver.

Step 6: Remove the Takeda intake tube from the vehicle.

**Figure C****Refer to Figure C for Step 7**

Step 7: Locate and disconnect the wire harness that is attached to the metal bracket on the bottom side of the turbo inlet. The wire harness will slide off of the bracket when pulled towards the driver side.





Figure D

**Refer to Figure D for Steps 8-9**

Step 8: Remove the three 10mm bolts securing the factory turbo inlet to the Turbo. These bolts will be reused.

Step 9: Remove the factory turbo inlet. Be careful not to drop or damage the turbo inlet gasket. The gasket will be reused for the installation of the Takeda Turbo Inlet.

**Figure E****Refer to Figure E for Steps 10-11**

Step 10: Using a 10mm nut driver or socket, remove the wire harness bracket from the factory turbo inlet.

Step 11: Transfer the bracket and bolt to the Takeda turbo inlet. Secure it as shown.

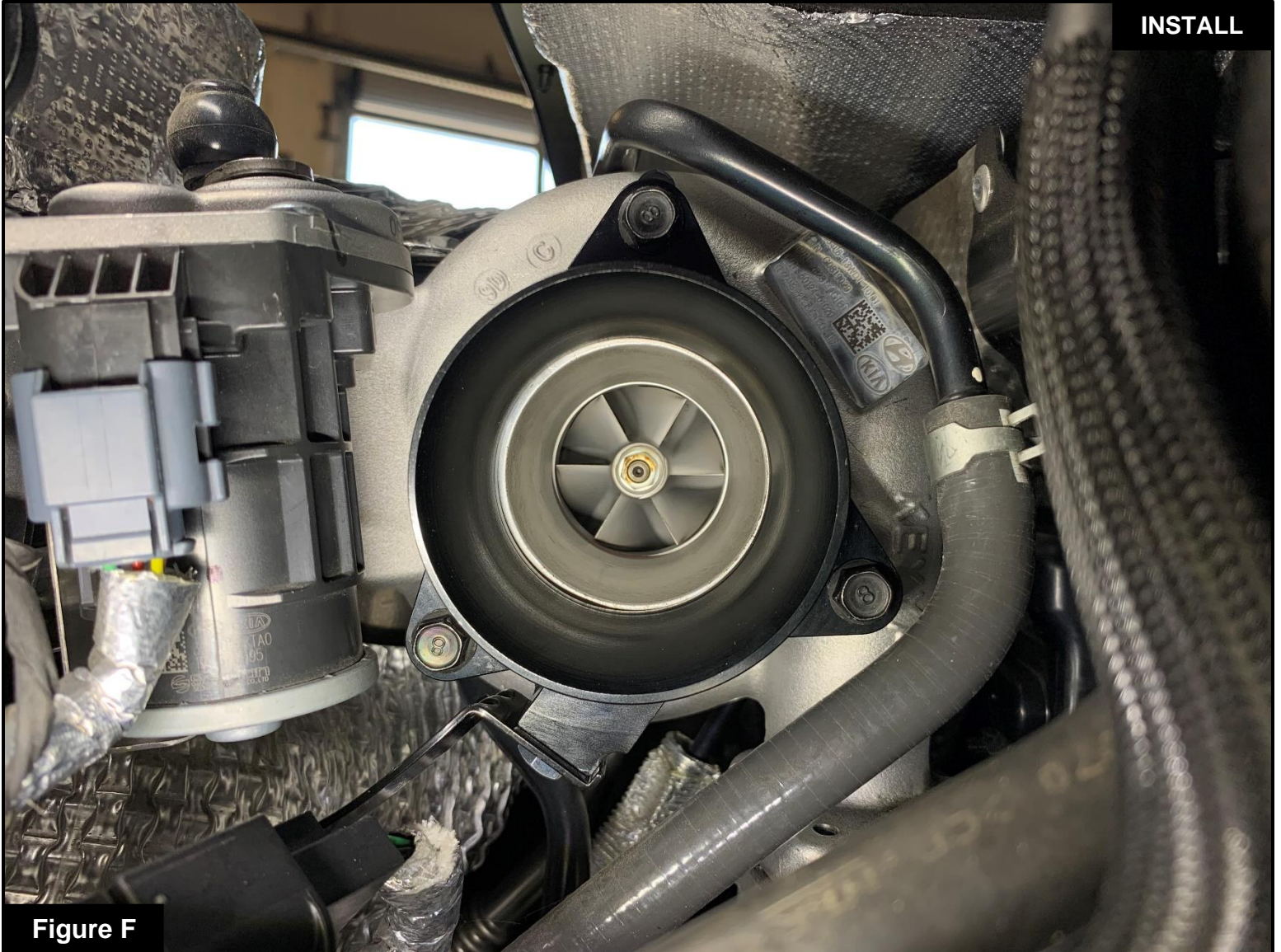

**Figure F****Refer to Figure F for Steps 12-13**

Step 12: Install the Takeda turbo inlet onto the turbo. Slide the factory gasket between the adaptor and turbo. Secure it using the three 10mm bolts removed at Step 8.

Step 13: Reconnect the wire harness to the bracket on the turbo inlet.



**Figure G****Refer to Figure G for Steps 14-16**

Step 14: Install the Takeda coupling onto the Takeda turbo inlet. Make sure to align the notch in the coupling with the aluminum adaptor to ensure correct orientation.

Step 15: Install the clamps on the coupling, but do not tighten the clamps yet.

Step 16: Remove the straight coupling from the Takeda intake tube.



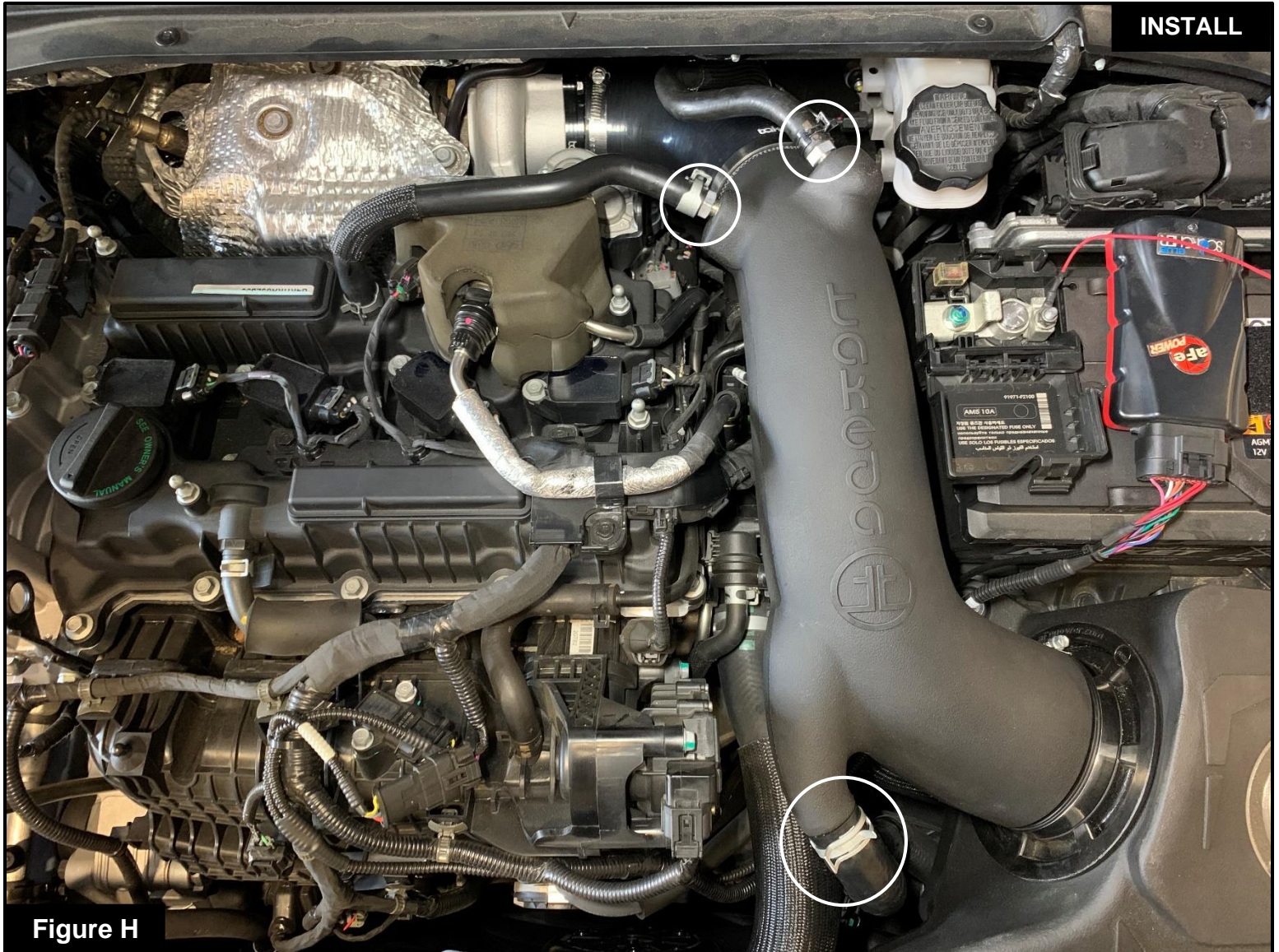

Figure H

**Refer to Figure H for Steps 17-21**

Step 17: Install the Takeda air intake tube into the takeda elbow coupling and reconnect the other end to the air filter. Make sure the tube and coupling are correctly aligned, then tighten all clamps.

Step 18: Remove the factory coupling from the factory air intake tube.

Step 19: Reconnect the three hoses that were disconnected at Step 2 and 4.

Step 20: Reinstall the engine cover.

Step 21: Make sure all clamps and connections are secured. Your installation is now complete. Thank you for choosing Takeda USA.



**Page left blank intentionally**





**Page left blank intentionally**



Pro DRY S Air Filter



P/N: 49-37008-B

Pro 5R Air Filter



P/N: 49-37007-B

Pre-Filter

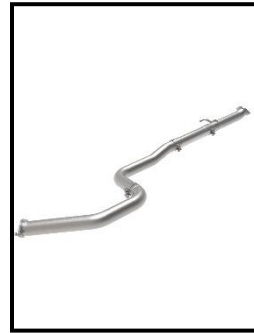

P/N: 49-37006

Pro DRY S Restore Kit



P/N: 90-59999

Blue Squeeze Restore Kit



P/N: 90-50501

Tactical Backpack



P/N: 40-33205-B

Flashlight LED



P/N: 40-10202

Mechanic Gloves (L)



P/N: 40-10149

Scorcher GT Power Module



P/N: 77-47004

To purchase any of the items above, view airflow charts, dyno graphs, photos, and video; please go to [aFepower.com](http://aFepower.com).





# Warranty

## General Terms:

- aFe warrants their products to be free from manufacturer's defects due to workmanship and material.
- This warranty applies only to the original purchaser of the product and is non-transferrable.
- Proof of purchase of the aFe product is required for all warranty claims.
- Warranty is valid provided aFe instructions for installation and/or cleaning were properly followed.
- Proper maintenance with regular inspections of product is required to insure warranty coverage.
- Damage due to improper installation, abuse, unauthorized repair or alteration is not warranted.
- Incidental or consequential damages or cost, including installation and removal of part, incurred due to failure of aFe product is not covered under this warranty.
- All warranty is limited to the repair and/or replacement of the aFe part. To request Return Goods Authorization ("RGA"), email RGA@afepower.com or call (951)493-7100. Upon receipt of the RGA, you must return the product to the address provided in the RGA, freight prepaid and accompanied with a dated proof of purchase and the RGA. Upon receipt of the defective product and upon verification of proof of purchase, aFe will either repair or replace the defective product within a reasonable time, not to exceed thirty days.

Product Category	P/N Prefix	Warranty duration
Direct OE Replacement Filters	10, 11, 30, 31, 71, 73	Life of the vehicle
Racing Filters	18	1 year
Universal	20, 21, 23, 24, 72, TF	2 years
Air Intake Systems	50, 51, 53, 54, 56, 57, 58, 59, 75, TR, TA, TL, TM	2 years
Exhaust Systems	49	2 years
Intercoolers & Intercooler Tubes	46-2	2 years
Intake Manifolds	46-1	2 years
Differential Cover	46-7	Life of the vehicle
Exhaust Manifolds	46	2 years
Throttle Body Spacers	46-3	2 years
Turbochargers	46-6	2 years*
Fluid Filters	44	90 days
Pre-Filters	28	2 years
Heavy Duty OE Replacement	70	2 years
PowerSports OE Replacement	81, 87	2 years
PowerSports Intake Systems	85	2 years

No other warranty expressed or implied applies nor is any person or advanced FLOW engineering authorized to assume any other warranty. Some States do not allow the exclusion or limitation of incidental or consequential damages or do not allow limitations on how long an implied warranty lasts, so the above limitations or exclusions may not apply to you. This warranty gives you specific legal rights, and you may also have other rights which vary from State to State.

\*See turbocharger warranty for more info



***advanced FLOW engineering, inc.***

252 Granite Street Corona, CA 92879  
TEL: 951.493.7100 • TECH: 951.493.7185  
E-Mail: Tech@aFepower.com

P/N: 06-81365