



AIRCHARGER®

HIGH-FLOW INTAKE KITS

LEGAL IN CALIFORNIA ONLY FOR RACING VEHICLES WHICH MAY NEVER BE USED, REGISTERED OR LICENSED FOR USE UPON A HIGHWAY.
See knfilters.com for CARB status on each part for a specific vehicle

INSTALLATION INSTRUCTIONS

63-3083
CADILLAC
2013-16 ATS
L4-2.5L

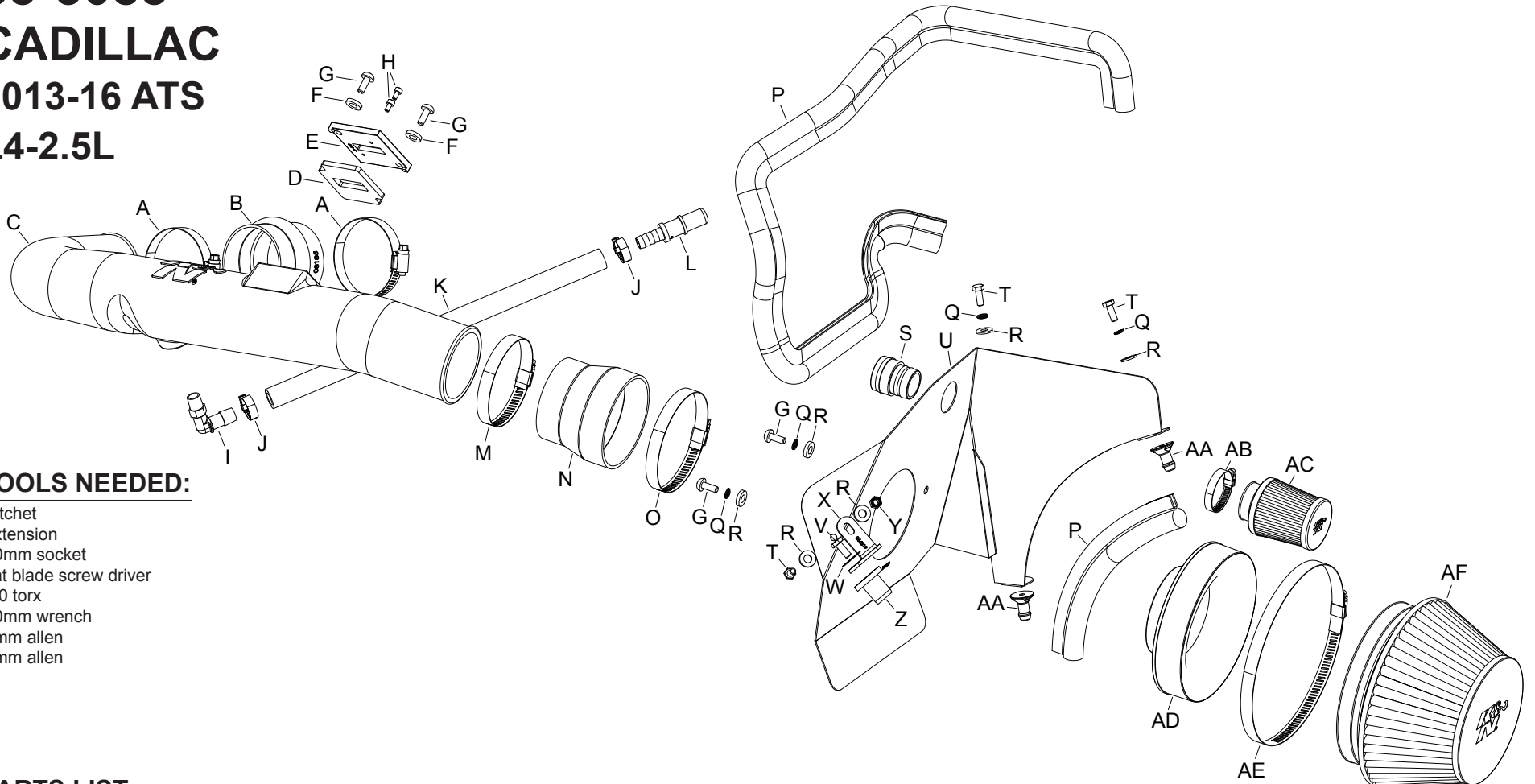

TOOLS NEEDED:

- ratchet
- extension
- 10mm socket
- flat blade screw driver
- t20 torx
- 10mm wrench
- 4mm allen
- 3mm allen

PARTS LIST:

Description	Qty.	Part #	Description	Qty.	Part #	Description	Qty.	Part #
A Hose Clamp #40	2	08554	L Vent; 1/2" Barb To quick	1	82629	W Washer; 3/8" Flat Washer, SS	1	08134
B Hose; 2-3/4" ID X 2-1/2"L Hump	1	08185	M Hose Clamp #48	1	08601	X Bracket; "L", 63-3083, STL	1	064319
C Intake Tube	1	087281A	N Hose; 3-1/2" To 3" ID X 3"L TPRD	1	084055	Y Nut; 6MM Nylock, Hexhead, SS	1	07512
D Gasket; 57-2556, 3/16 Poron	1	09069	O Hose Clmap #56	1	08620	Z Insert; 3/8-16 X 3/400 X 15/16	1	08163
E Adaptor; #420, Nylon 6/6 GF	1	21515	P Edge Trim (55")	1	102480	AA Mount, Plastic Airbox	2	8-186-1
F Washer; 6MM Flat, SS	2	08269	Q Washer; M6 Split Lock Zinc	4	1-3025	AB Hose Clamp #20 Mini	1	08431
G Bolt; M6 X 1.00 X 16MM, SS	4	07730	R Washer; 1/4" ID X 5/8" OD- SAE	6	08275	AC 1-1/8" FLG, 2 1/4" B, 2 "T", 21/2"	1	RC-2540
H Bolt; M4-0.07 8MM, A/H Cap, SS	2	07733	S Adaptor; 1-1/8" OD Quick	1	088012	AD Adapter; Universal, 6" Filter 3.5"	1	21512-1
I Vent; 90 DEG, 1/2" Hose, 1/4"	1	08110FK	T Bolt; 6MM-1.00 X 16MM, SS	3	07812	AE Hose Clamp #104	1	08697
J Hose Clamp #6 Mini	2	08407	U Heat Shield	1	073165	AF Air Filter	1	RF-1009
K Hose; 1/2" ID X 14"L	1	08402	V Bolt; 3/8"-16 X 1-1/4" L SS Hex	1	07779			

NOTE: FAILURE TO FOLLOW INSTALLATION INSTRUCTIONS AND NOT USING THE PROVIDED HARDWARE MAY DAMAGE THE INTAKE TUBE, THROTTLE BODY AND ENGINE.

TO START:

1. Turn off the ignition and disconnect the negative battery cable.
NOTE: Disconnecting the negative battery cable erases pre-programmed electronic memories. Write down all memory settings before disconnecting the negative battery cable. Some radios will require an anti-theft code to be entered after the battery is reconnected. The anti-theft code is typically supplied with your owner's manual. In the event your vehicles anti-theft code cannot be recovered, contact an authorized dealership to obtain your vehicles anti-theft code.

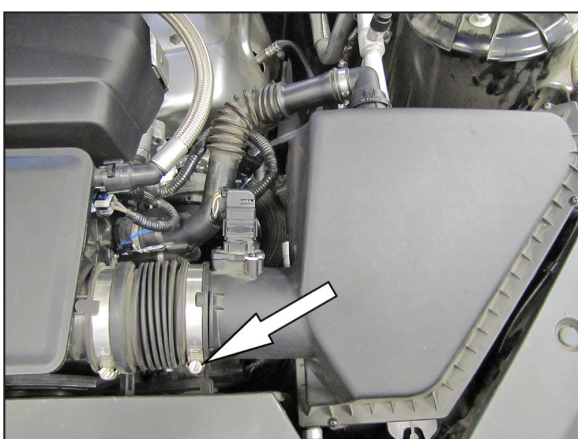

2. Loosen the hose clamp securing the intake tube to the air filter housing.

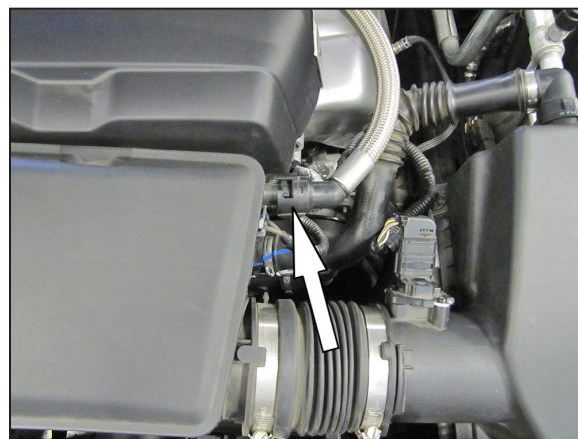

3. Disconnect the Crank case vent hose from the intake plenum.



4. Loosen the hose clamp securing the intake plenum to the throttle body.



5. Remove the intake plenum from the vehicle.

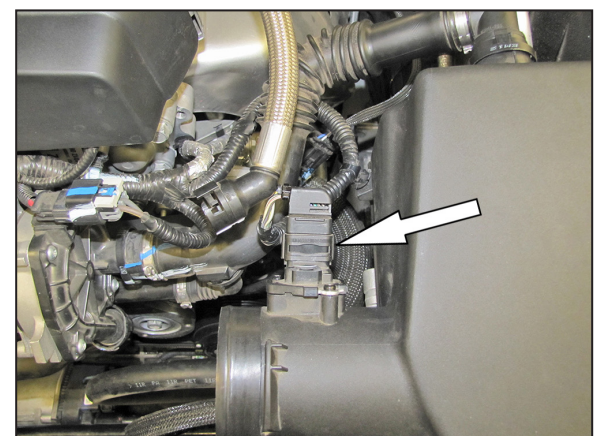

6. Disconnect the mass air sensor electrical connection and unhook the wiring harness from the air filter housing.

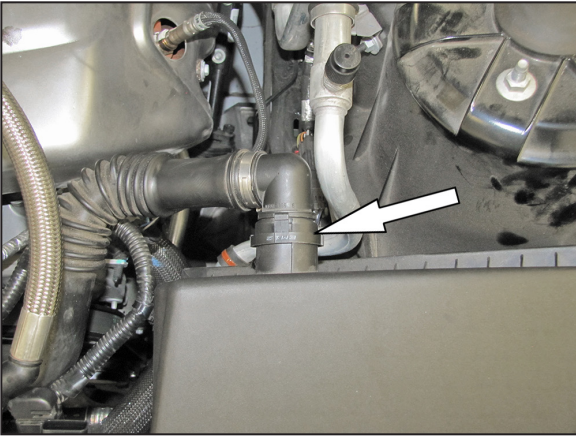

7. Disconnect the secondary air hose from the air filter housing.

NOTE: Some vehicles may not be equipped with the secondary air injection system.



8. Lift up the air filter housing to dislodge it from the mounting grommets and then remove it from the vehicle.

NOTE: K&N Engineering, Inc., recommends that customers do not discard factory air intake.

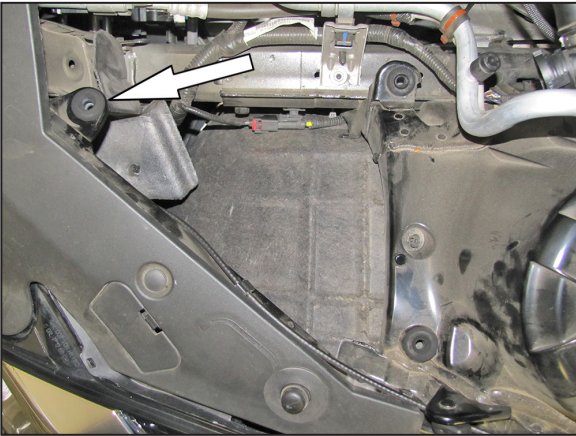

9. Remove the forward most air filter housing mounting grommet shown.

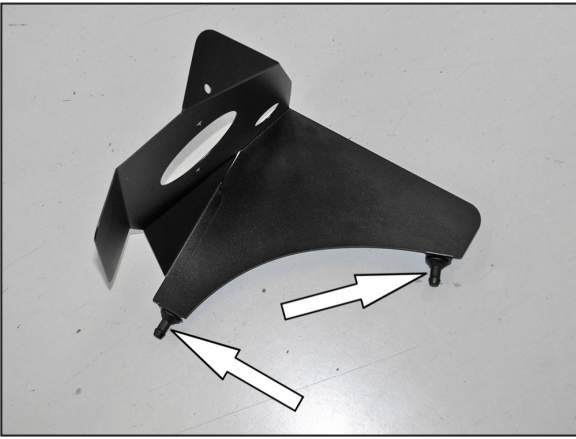

10. Install the two provided mounts onto the heat shield as shown using the provided hardware.



11. Install the insert nut onto the bracket (064319) as shown.

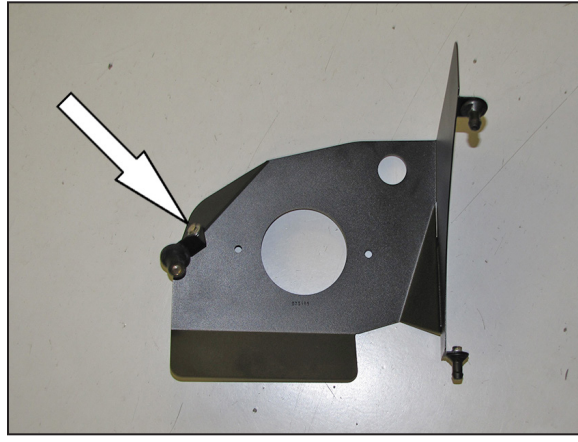

12. Install the bracket assembly onto the heat shield but do not completely tighten at this time.

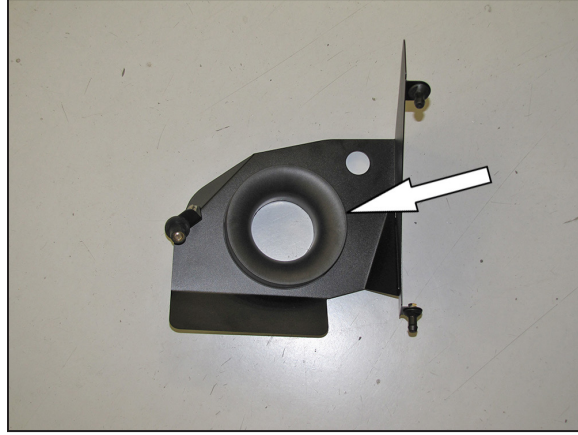

13. Install the filter adapter into the heat shield and secure with the provided hardware.

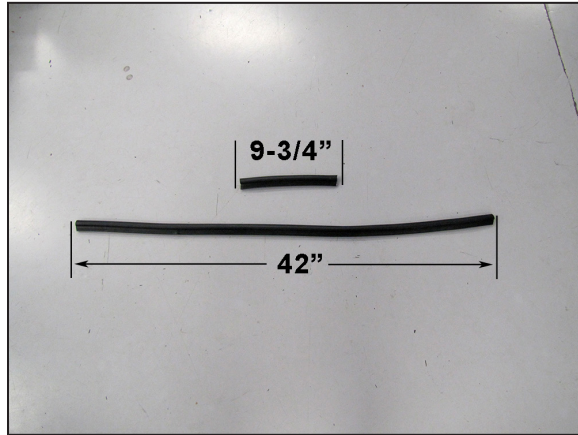

14. Cut the provided edge trim into two sections as shown. One section is 9-3/4" long and the other section is 42" long.



15. Install the provided edge trim onto the heat shield as shown.



16. Install the secondary air filter onto the heat shield using the provided adapter.
NOTE: On vehicles that are not equipped with a secondary air system it is not necessary to install the breather filter.



17. Install the K&N® air filter onto the filter adapter and secure with the provided hose clamp.

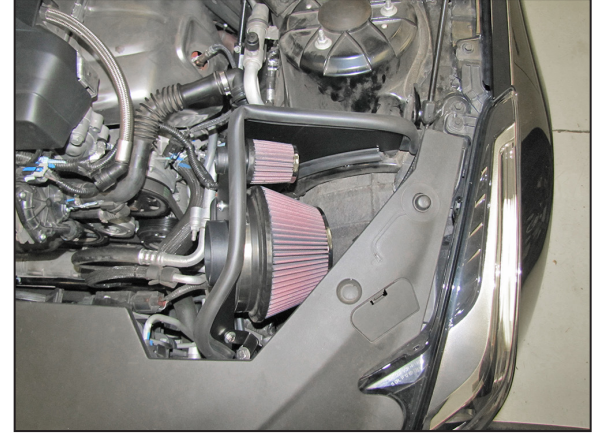

18. Install the heat shield assembly into the engine compartment so the mounting studs go into the mounting grommets and the insert nut goes into the front mounting grommet location. Secure the heat shield by tightening the bolt into the insert nut.

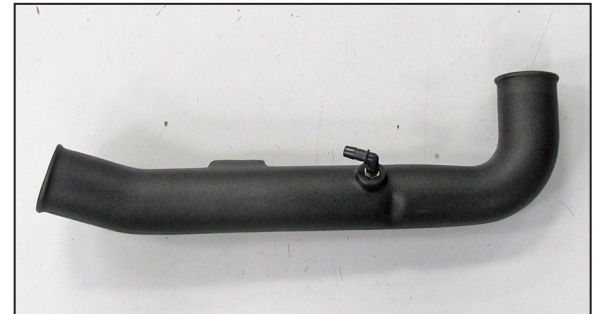

19. Install the provided vent fitting into the K&N® intake tube.

NOTE: Plastic NPT fittings are easy to cross thread. Install the vent fitting "hand" tight, then turn it two complete turns with a wrench.



20. Install the provided Quick connect union fitting into the provided vent hose and secure with the hose clamp provided.



21. Install the vent hose assembly onto the fitting installed into the K&N® intake tube and secure with the provided hose clamp.

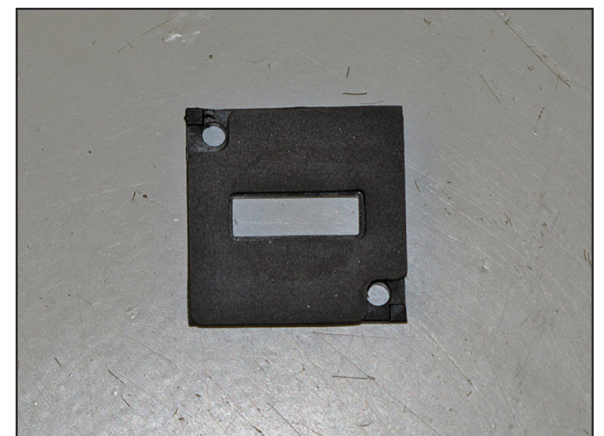

22. Install the provided gasket onto the K&N® mass air adapter.

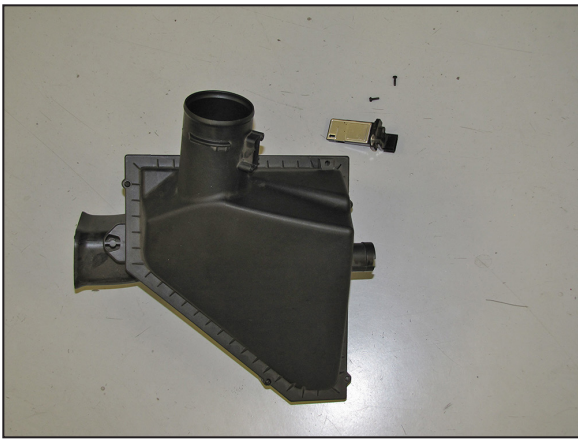

23. Remove the mass air sensor from the air filter housing.

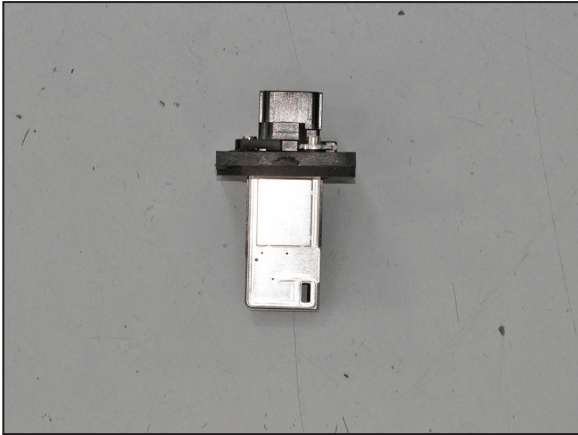

24. Install the mass air sensor into the K&N® adapter and secure with the provided hardware.

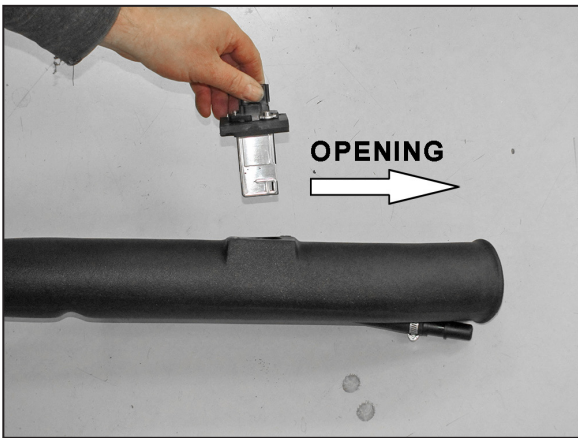

25. Install the mass air sensor into the K&N® tube with the opening facing the direction shown.

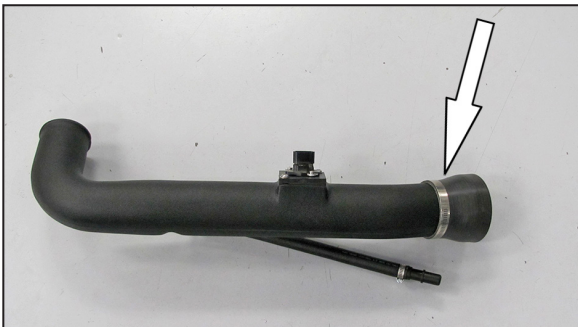

26. Install the provided Step coupler onto the K&N® intake tube as shown.

NOTE: Do not completely tighten at this time.

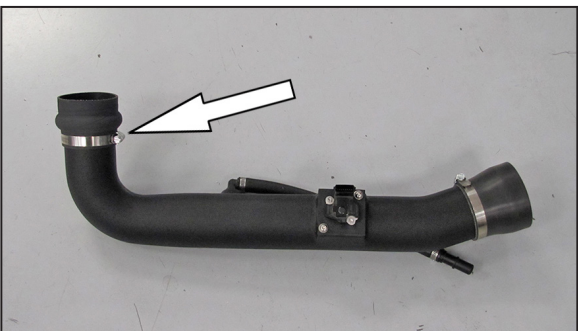

27. Install the provided hump coupler (08185) onto the K&N® intake tube and secure with the provided hose clamp.

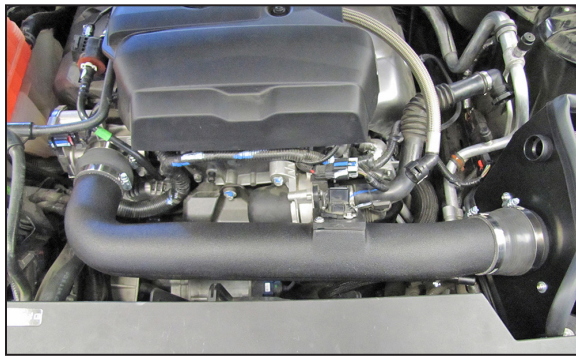

28. Install the K&N® intake tube assembly onto the filter adapter and then onto the throttle body. Adjust the tube and step hose for best fit and then secure with the provided hose clamps.

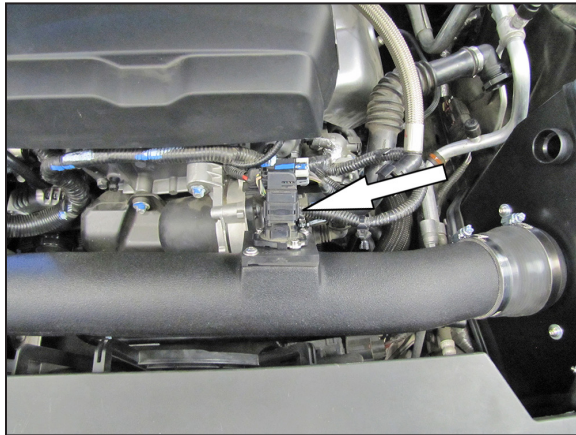

29. Reconnect the mass air sensor electrical connection.

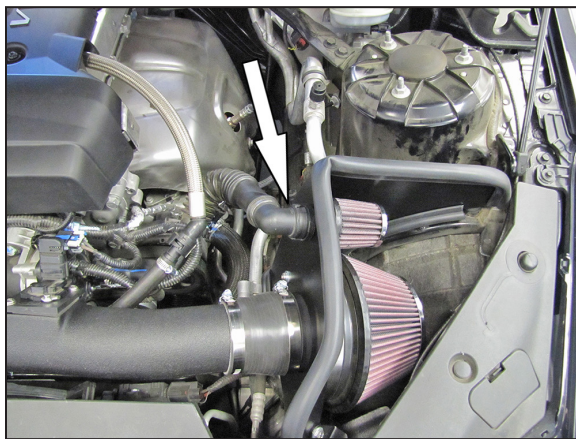

30. On vehicles equipped with secondary air, connect the secondary air hose to the adapter installed into the Heat shield as shown.
NOTE: It will be necessary to twist the 90° fitting in the hose so that it will connect with the adapter.



31. Reconnect the vehicle's negative battery cable. Double check to make sure everything is tight and properly positioned before starting the vehicle.

32. It will be necessary for all K&N® high flow intake systems to be checked periodically for realignment, clearance and tightening of all connections. Failure to follow the above instructions or proper maintenance may void warranty.

ROAD TESTING:

1. Start the engine with the transmission in neutral or park, and the parking brake engaged. Listen for air leaks or odd noises. For air leaks secure hoses and connections. For odd noises, find cause and repair before proceeding. This kit will function identically to the factory system except for being louder and much more responsive.

2. Test drive the vehicle. Listen for odd noises or rattles and fix as necessary.

3. If road test is fine, you can now enjoy the added power and performance from your kit.

4. K&N Engineering, Inc., requires cleaning the intake system's air filter element every 100,000 miles. When used in dusty or off-road environments, our filters will require cleaning more often. We recommend that you visually inspect your filter once every 25,000 miles to determine if the screen is still visible. When the screen is no longer visible some place on the filter element, it is time to clean it. To clean and re-oil, purchase our filter Recharger® service kit, part number 99-5050 or 99-5000 and follow the easy instructions.

LEGAL IN CALIFORNIA ONLY FOR RACING VEHICLES WHICH MAY NEVER BE USED, REGISTERED OR LICENSED FOR USE UPON A HIGHWAY.

See knfilters.com for CARB status on each part for a specific vehicle