



TYPHOON INTAKE SYSTEMS

SOME INTAKE SYSTEMS ARE NOT LEGAL FOR SALE OR USE ON ANY POLLUTION CONTROLLED MOTOR VEHICLE IN CALIFORNIA OR STATES ADOPTING CALIFORNIA EMISSION PROCEDURES.

See knfilters.com for CARB status on each part for a specific vehicle

INSTALLATION INSTRUCTIONS

69-6027TTK

MAZDA

2007-08 Mazda 6

L4-2.3L

NOTE: C.A.R.B. E.O. # D-269-37 EXCLUDES LEV2 SULEV 2007 & 2008 TEST GROUPS 7TKXV02.3NH1 & 8TKXV02.3NH2

TOOLS NEEDED:

3mm Allen Wrench
10mm Socket
12mm Socket
Extension
Flat Blade Screwdriver
Phillips Screwdriver
Pliers
Ratchet

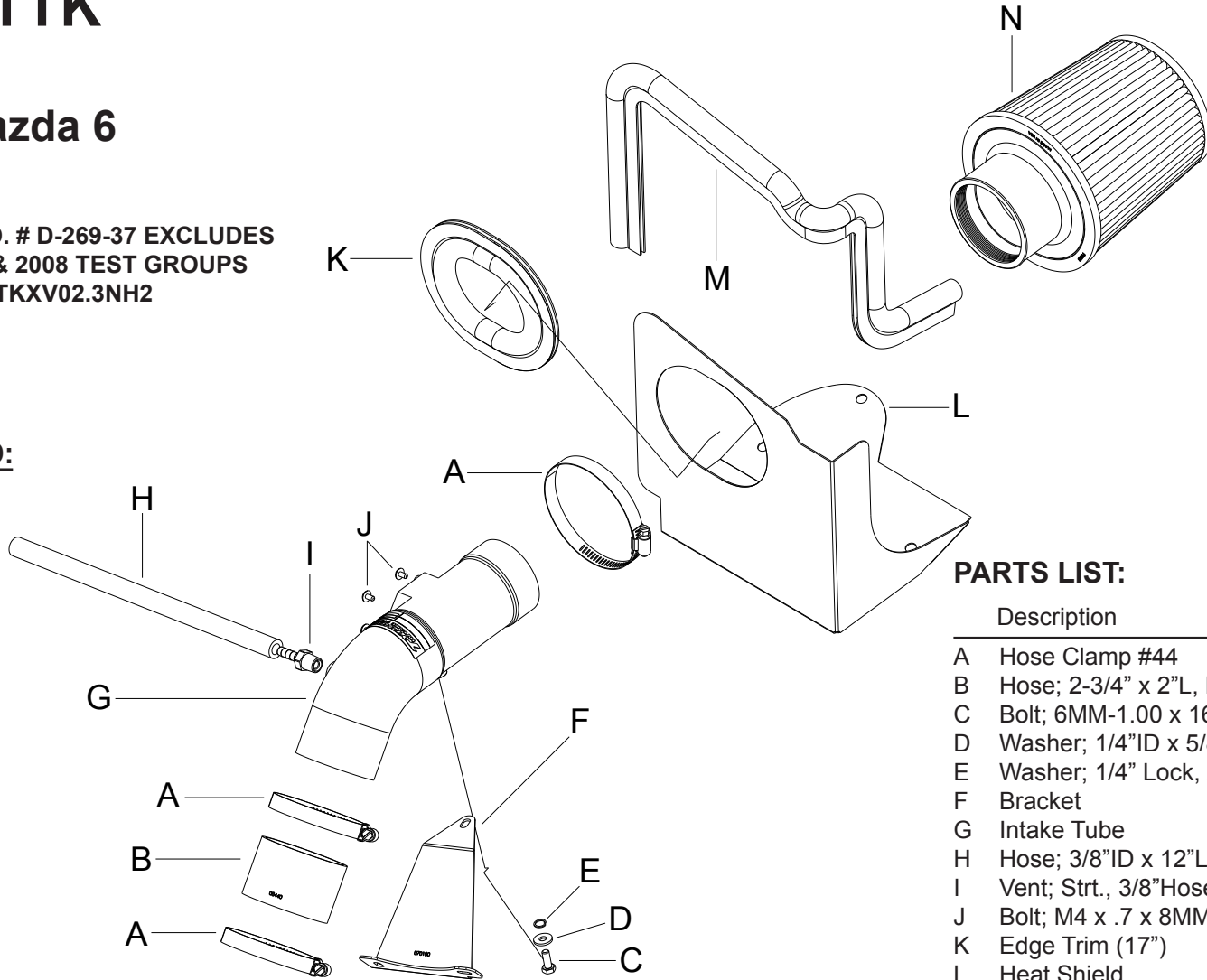

PARTS LIST:

Description	Qty.	Part #
A Hose Clamp #44	3	08577
B Hose; 2-3/4" x 2"L, Blk.	1	08440
C Bolt; 6MM-1.00 x 16MM, SS	1	07812
D Washer; 1/4"ID x 5/8"OD - SAE	1	08275
E Washer; 1/4" Lock, ZN	1	08198
F Bracket	1	070100
G Intake Tube	1	27556
H Hose; 3/8"ID x 12"L, Silicone	1	08412
I Vent; Strt., 3/8"Hose, 1/4"NPT	1	08047
J Bolt; M4 x .7 x 8MM, Bttnhd, SS	2	07741
K Edge Trim (17")	1	102469
L Heat Shield	1	074049
M Edge Trim (35")	1	102471
N Air Filter	1	RU-4870

NOTE: FAILURE TO FOLLOW INSTALLATION INSTRUCTIONS AND NOT USING THE PROVIDED HARDWARE MAY DAMAGE THE INTAKE TUBE, THROTTLE BODY AND ENGINE.

TO START:

1. Turn off the ignition and disconnect the negative battery cable.

NOTE: Disconnecting the negative battery cable erases pre-programmed electronic memories. Write down all memory settings before disconnecting the negative battery cable. Some radios will require an anti-theft code to be entered after the battery is reconnected. The anti-theft code is typically supplied with your owner's manual. In the event your vehicles' anti-theft code cannot be recovered, contact an authorized dealership to obtain your vehicles anti-theft code.

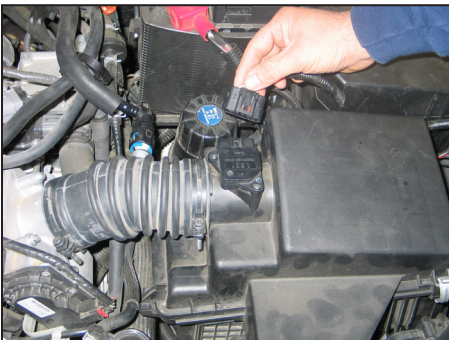

2. Disconnect the mass air sensor electrical connection.



3. Disconnect the crankcase vent hose from the intake tube as shown.

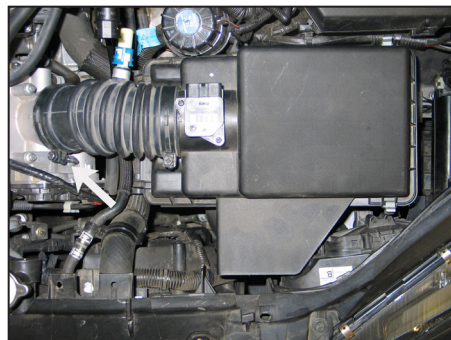

4. Loosen the hose clamp which secures the intake tube to the throttle body.



5. Pull up firmly on the airbox assembly to dislodge it from the mounting grommets and then remove the airbox assembly from the vehicle.
NOTE: K&N Engineering, Inc., recommends that customers do not discard factory air intake.

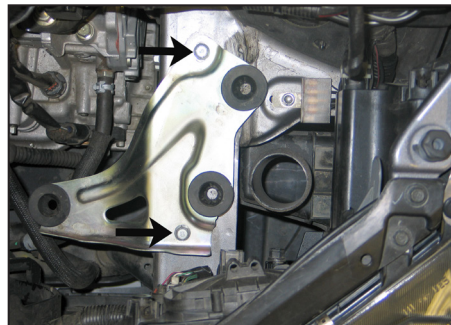

6. Remove the two bolts which secure the airbox mounting bracket to the inner fender and then remove the bracket from the vehicle.
NOTE: These bolts will be reused in a later step.



7. Remove the bolt which retains the ground strap to the inner fender.

NOTE: This bolt will be reused in a later step.

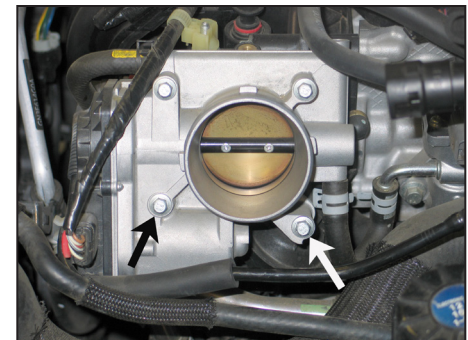

8. Remove the two lower throttle body mounting bolts shown.

NOTE: These bolts will be reused in the next step.



9. Install the intake tube mounting bracket onto the throttle body and secure with the original bolts removed in the previous step.

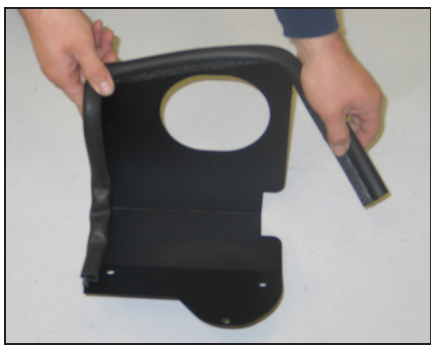

10. Install the provided long edge trim onto the heat shield as shown.

NOTE: Some trimming of the edge trim will be necessary.

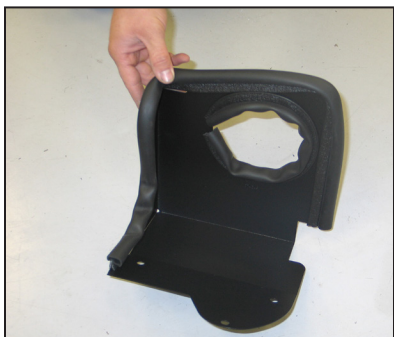

11. Install the provided short edge trim into the hole of the heat shield as shown.

NOTE: Some trimming of the edge trim will be necessary.

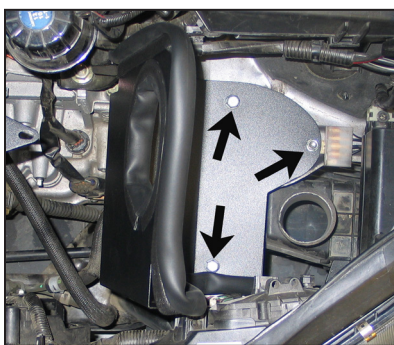

12. Install the heat shield assembly onto the inner fender and secure with the factory bolts removed during steps #6 and #7.

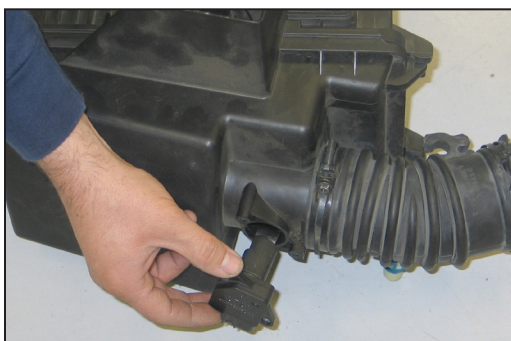

13. Remove the two bolts which secure the mass air sensor to the factory airbox and then remove the mass air sensor as shown.



14. Install the mass air sensor into the K&N intake tube and secure with the provided hardware.

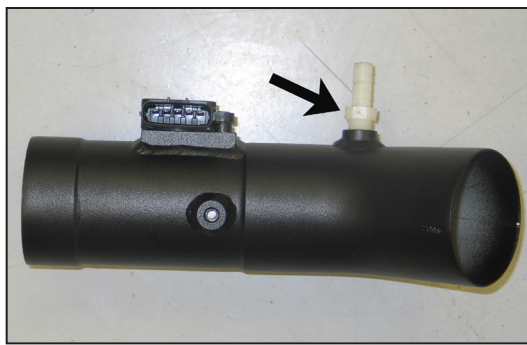

15. Install the provided vent fitting into the K&N intake tube as shown.

NOTE: Plastic NPT fittings are easy to cross thread. Install the vent fitting "hand" tight, then turn it two complete turns with a wrench.



16. Remove the crankcase vent fitting from the engine valve cover, and then cut off the intake tube end of the assembly 2.5" from the end as shown. Reinstall the crankcase tube onto the valve cover.



17. Install the silicone hose (08440) onto the throttle body and secure with the provided hose clamp.



18. Install the K&N intake tube into the silicone hose at the throttle body and align with the tube mounting bracket. Secure the intake tube with the provided hose clamp and hardware.

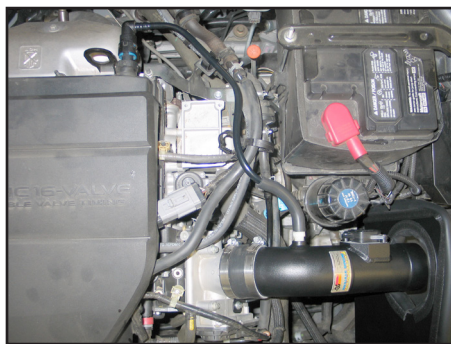

19. Install the provided crankcase vent hose onto the factory vent tube and onto the vent fitting installed into the K&N intake tube as shown.



20. Install the K&N air filter onto the K&N intake tube and secure with the provided hose clamp.

NOTE: Drycharger air filter wrap; part # RX-4730DK is available to purchase separately. To learn more about Drycharger filter wraps or look up color availability please visit <http://www.knfilters.com>.



21. Reconnect the mass air sensor electrical connection.



22. Reconnect the vehicle's negative battery cable. Double check to make sure everything is tight and properly positioned before starting the vehicle.

23. It will be necessary for all K&N high flow intake systems to be checked periodically for realignment, clearance and tightening of all connections. Failure to follow the above instructions or proper maintenance may void warranty.

24. The C.A.R.B. exemption sticker, (attached), must be visible under the hood so that an emissions inspector can see it when the vehicle is required to be tested for emissions. California requires testing every two years, other states may vary.

ROAD TESTING:

1. Start the engine with the transmission in neutral or park, and the parking brake engaged. Listen for air leaks or odd noises. For air leaks secure hoses and connections. For odd noises, find cause and repair before proceeding. This kit will function identically to the factory system except for being louder and much more responsive.

2. Test drive the vehicle. Listen for odd noises or rattles and fix as necessary.

3. If road test is fine, you can now enjoy the added power and performance from your kit.

4. K&N Engineering, Inc., suggests checking the air filter element periodically for excessive dirt build-up. When the element becomes covered in dirt (or once a year), service it according to the instructions on the Recharger service kit, part number 99-5050 or 99-5000.

SOME INTAKE SYSTEMS ARE NOT LEGAL FOR SALE OR USE ON ANY POLLUTION CONTROLLED MOTOR VEHICLE IN CALIFORNIA OR STATES ADOPTING CALIFORNIA EMISSION PROCEDURES.

See [knfilters.com](http://www.knfilters.com) for CARB status on each part for a specific vehicle