



# Installation Instructions

## C-4 Conversion Kit for Mustang Console Hammer Shifter

### Part No. 81020

©1999 B&M Racing and Performance Products

The **B&M Mustang Hammer C-4 Conversion Kit** is intended for use in a 1987-99 Mustang that has had a C-4 or C-5 transmission installed in place of the original AOD transmission. This kit is used in conjunction with the B&M Mustang Hammer shifter (part Nos. 81001, 81002 or 81003). This kit includes a shifter cable and transmission cable bracket and shift lever for a C-4 or C-5 transmission.

Please read the instructions and review the illustrations thoroughly before beginning the installation. The installation of the shifter into the car is covered in the instructions with the shifter itself as well as these instructions. Follow the steps as shown below.

#### INSTALLATION

**STEP 1.** Before the shifter is installed in the car the Neutral safety switch, the back up light switch and the cam plate that operates the switches must be installed on the shifter. Also a different cable pin must be installed on the shifter to work with the B&M cable.

The cam plate is screwed onto shift indicator arm with a #4 self tapping screw. (**See figure 1**) Put a lockwasher under the head of the screw. If your shifter does not have

this hole drilled, use template #1 and drill a .098" dia. (#40 drill) hole to install the cam plate.

The switches are installed as shown in **figure 2**. The switch support is attached to the shifter base plate with two #10 screws and nuts. If these two holes are not drilled in your shifter, drill two 7/32" holes using template #2. The two switches are installed on the switch support with two #4 screws, nuts and lock washers. Put a lock washer between the screw head and the switch on each side in addition to the lock washer under the nut.

The cable pin on the shifter must also be changed. (**See figure 3**) Remove the ball shaped cable pin and replace it with the pin type cable pin included in this kit. Tighten the nut securely. The B&M cable bracket spacer must also be installed. It is secured to the **BACK** side of the shifter cable bracket using the two #14 X 5/8" self tapping screws included with shifter. (**See figure 4**)

**STEP 2.** Under the car remove the nut and lockwasher holding the downshift linkage onto the downshift lever shaft if there is any on your vehicle. The downshift lever is the outer lever on C-4 and C-5 transmissions. Pull the lever off the shaft and allow the

linkage to hang free. Most C-4 and C-5 transmissions have a Neutral safety/Backup light switch on the transmission shift lever. If your transmission is so equipped, remove the two bolts holding the switch in place and slide it off the shift shaft. Disconnect the switch at the factory plug and discard it. You will need to connect the Neutral safety switch and backup light switch wiring that is in this wiring harness to the switches on the shifter. **STEP 3.** Install the **B&M** selector lever, (**See figure 5**). Note: The B&M lever must point downward for proper operation. If the stock shift lever on your transmission points down, you will have to remove the lower part of the stock arm by cutting it off to clear the **B&M** lever, (**See figure 5**). Install **B&M** selector lever onto shift shaft of transmission. Align selector lever so when it points straight down it travels equal arcs in both directions from center, then tighten 1/4"-20 x 1 1/2" pinch bolt and nut. The lever should travel smoothly from front to back with a positive click in each gear position. Make sure O-ring is in position on downshift shaft and install downshift lever in position on shaft. Install lockwasher and nut and tighten securely. Downshift lever must operate

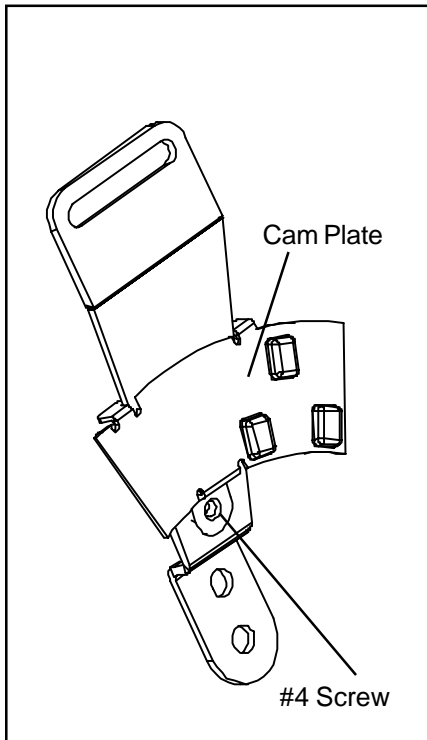

Figure 1

smoothly. Reconnect downshift linkage, if used.

**STEP 4.** Cable bracket installation: Remove the two lower bolts from the rear servo cover. Install cable bracket in position, (**See figure 5**). Install two servo cover bolts as removed and tighten 12-13 lb-ft. Do not over tighten as this can distort servo cover.

**STEP 5.** Install the shifter in the car as described in the shifter installation instructions. Continue through step 3. Then install the supplied B&M cable in the car, routing the cable the same as the original Ford cable. Attach it to the underbody in the same locations as the Ford cable. Do not route it close to the exhaust. Connect the cable to the cable bracket spacer. The tab on the cable goes on the front side of cable bracket spacer.

Remove the two rubber boots, one large nut, and a large lockwasher from the threaded end of the shifter cable. Slide the end of the cable into the cable bracket, Install large nut and lockwasher loosely over end of cable. Install two rubber boots onto end of cable. Install the swivel on the threaded end of the cable and position it in the center of the threaded portion.

**STEP 6.** Move the transmission selec-

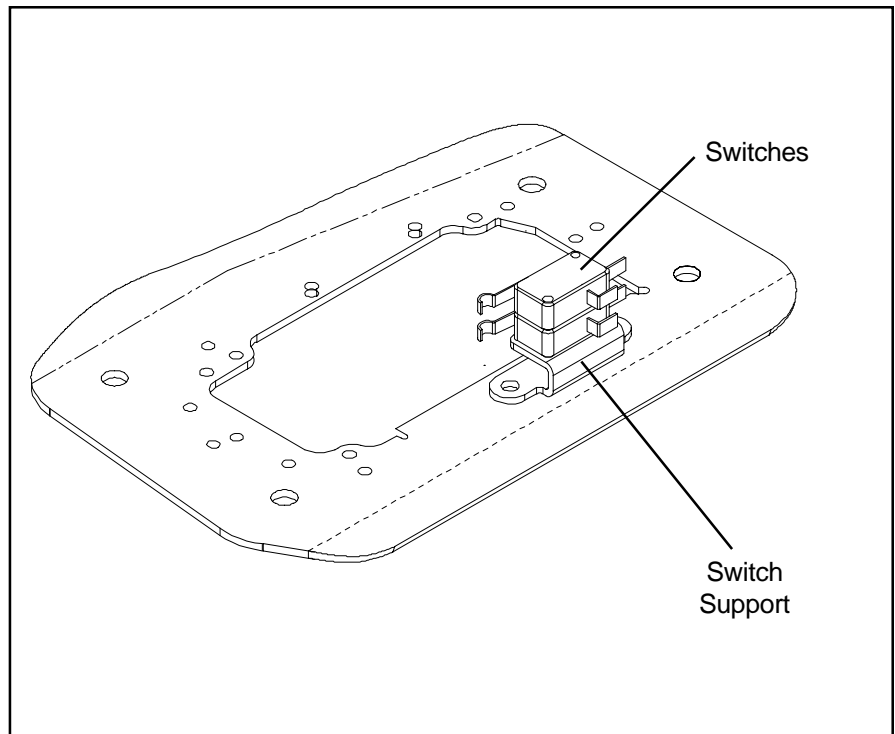

Figure 2

tor lever by hand to full rear position (LOW). Place the shifter lever to the low gear position (ratcheted all the way back). Adjust the large nuts on the cable so that the swivel will slide into the hole on the selector lever. Tighten the large nuts completely. Be sure that the swivel will slide freely in and out of the hole in the selector lever.

Adjust the cable with the procedure shown here, rather than the procedure in the shifter instructions. With the swivel in the selector lever, ratchet the shifter to PARK position, as far forward as the shifter will go without forcing it. The shift lever on the transmission should be all the way forward. Check to see that the swivel will slide freely in and out of the hole in the lever in this position. If it does not slip in freely, adjust the swivel slightly until it will slip into the hole in the lever in both LOW and PARK positions. Operate shifter through all gear positions. Check to make sure swivel will slide in and out of the selector lever hole in each gear position. Install cotter key supplied with shifter into swivel and spread key ends.

If you have a problem, **DO NOT FORCE THE SHIFTER**, this will dam-

age the cable, the shifter or the transmission. Simply start at the beginning and carefully check all your steps.

If your vehicle has an ignition and/or brake interlock adjust the interlock cable as shown in the shifter instructions.

In addition to wiring the indicator light in the shifter, it will be necessary to hook up the Neutral safety and Backup light switches on the shifter. In the plug that originally connected to the switch on the transmission locate and identify the Neutral safety switch wires. (The engine will not crank unless these wires are connected together), and backup light wires. Disconnect Battery ground cable before beginning to wire the Neutral safety and backup light switches. Reroute the wires to the shifter and lengthen if necessary. Strip 1/4" insulation off wires and install supplied slip-on terminals. Crimp terminals onto wires using a crimping tool or pliers. Connect the Neutral safety wires to the **LOWER** switch and the Reverse light wires to the **UPPER** switch, See **figure 1**. Tape terminal connections to prevent shorts. Reconnect battery ground cable, disconnect coil wire and set the parking brake. Check switch

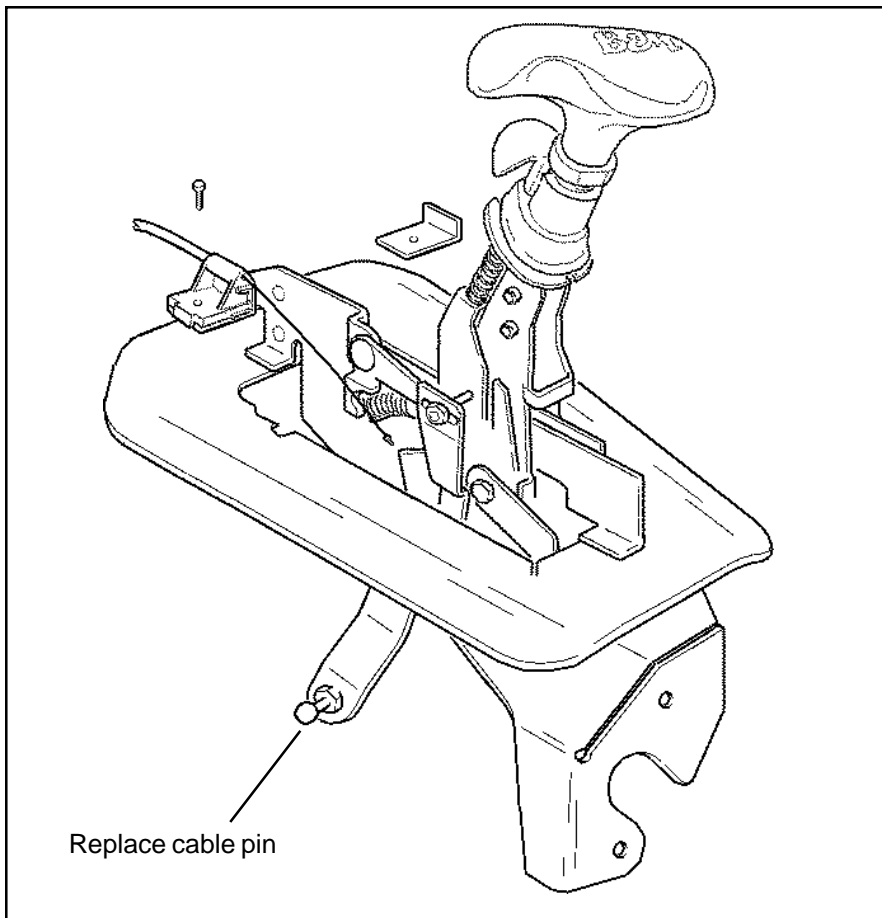

Figure 3

operation by attempting to start motor in each shifter position. **The starter must crank only when shifter is in the Park or Neutral position.** Check Backup light operation when the shifter is shifted to the Reverse position. Adjust switches if required. Reconnect coil wire.

After the switches are correctly wired, continue with replacing the console and installing the top plate as covered in the shifter instructions.

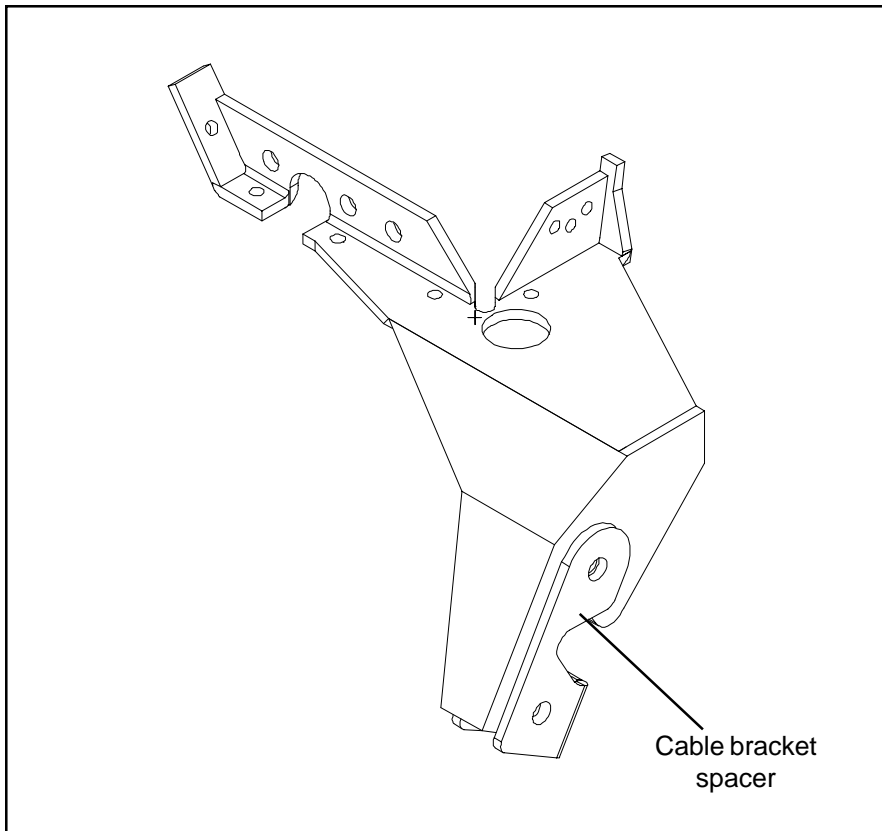

Figure 4

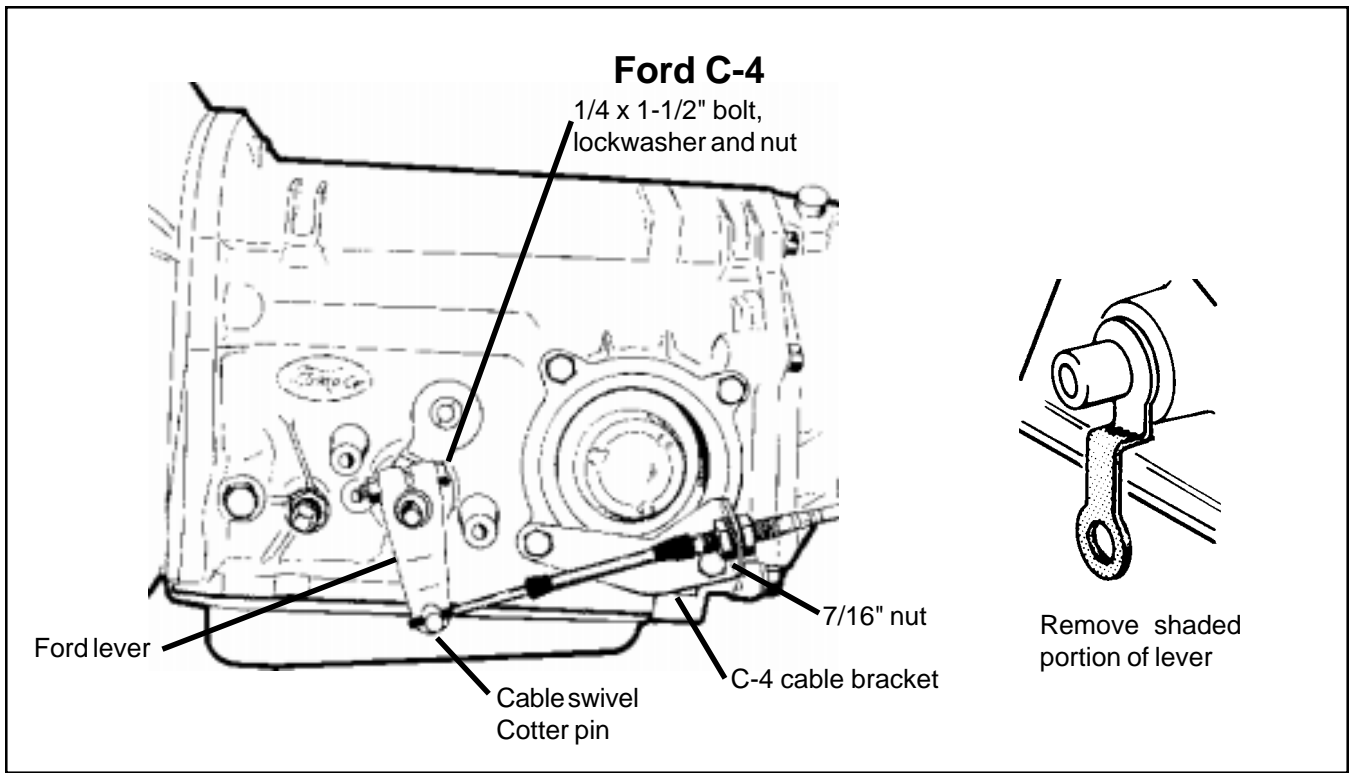

Figure 5

