



Equipped with AEM® Dryflow™ Filter
No Oil Required!

INSTALLATION INSTRUCTIONS

PART NUMBER

21-795C (GUN METAL GRAY FINISH)

2016	HONDA	PILOT	3.5L	V6
2017	HONDA	RIDGELINE	3.5L	V6

Not legal for sale or use on any pollution controlled motor vehicle in California or states adopting California emission procedures. See AEMIntakes.com for CARB status on each part for a specific vehicle.

ITEM NO.	PART NUMBER	DESCRIPTION	QTY.
1	2-1576C	TUBE; 3.50"OD X 15", 21-795, GUNMETAL GRAY	1
2	20-8582	HEAT SHIELD, HONDA PILOT 3.5L, 2016, TB/PC	1
3	21-2047DK	AIR FILTER; 3.5" X 7" DRYFLOW	1
4	08496	HOSE; 3.5"ID TO 3.25"ID X 2.5"L TPRD REINFORCED	1
5	8-163	VACUUM CAP, REDUCER .625-.190	1
6	102454	EDGE TRIM; 3/4"BULB, TOP LOC, 70"L	1
7	5-5002	HOSE; 1/2"ID X 2"L	1
8	22224	BOLT; M6X1.00X12 HEX; FLG, GRADE 10.9, GEO	2
9	08160	WASHER; 1"D X 1/4 HOLE FENDER	1
10	070228	STUD; RUBBER MNT, M/F, 1/2"L X 1"W, M6 X 1.00	1
11	21685	WASHER; 1" X .300 X .100 RUBBER	1
12	1-113	ZIP TIE,6 LONG	2
13	9452	1/2" BNDHOSE CLAMP,2.90"-3.75"	1
14	9456	1/2" BNDHOSE CLAMP,3.15"-4.00"	2

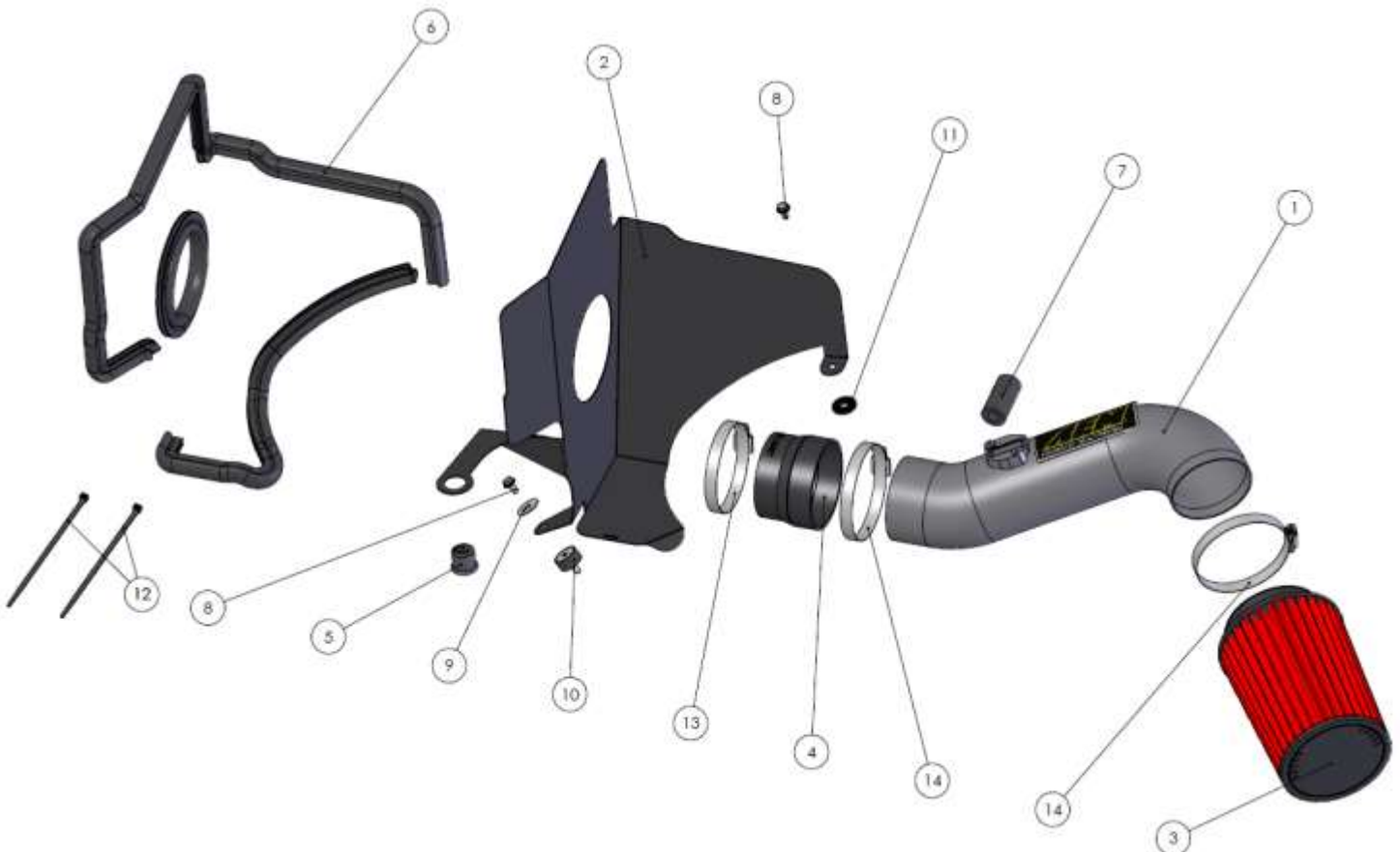

Read and understand these instructions **BEFORE** attempting to install this product. Failure to follow installation instructions and not using the provided hardware may damage the intake tube, throttle body and engine.

1. Preparing Vehicle

- a. Make sure vehicle is parked on level surface.
- b. Set the parking brake.
- c. If engine has run in the past two hours, let it cool down.
- d. Disconnect negative battery terminal.
- e. Do not discard stock components after removal of the factory system.
- f. Open the air intake kit package and make sure all parts are included.

Tools Needed:	Side Cutters
Screwdriver	Optional:
10mm Socket	Small Torque Wrench
5.5mm Socket	
Long Extension	
Socket Driver	

2. Removal of stock system



a. Remove the plastic engine cover by pulling up with both hands, tilting the cover towards you so that it can be maneuvered out of the engine bay.



b. Remove the plastic core support cover by pulling up gently, from right to left, disengaging the clips holding it in place. Bring cover towards you to clear hood latch. Note: Clips can sometimes be knocked loose from cover.



c. Unclip the MAF sensor connector and remove its wire from the intake hose clip and tuck it out of the way.



d. Unbolt the factory air box mount at the driver's side inner fender location.



e. Unbolt the factory air box behind the battery using a long extension and loosen hose clamp at air box side of intake hose.



f. Loosen hose clamp at throttle body side of intake hose and remove the vent tube by releasing the pressure on the spring clamp while pulling the vent tube.



g. Remove the two plastic pop-out mounts securing the cold air scoop by unscrewing them with a Philips screw driver. Note: Use care to not drop the clips as they are easily lost in the core support area.



h. Lift out cold air scoop, leaving rubber coupler on cold air scoop.



i. Remove the stock intake hose by first removing it from the air box and then collapsing the bellows so it can clear the air box. Then, remove it from the throttle body and engine bay.



j. Unclip the three wire harnesses from the air box bracket by depressing each latch and sliding them from the clips.



k. Remove factory air box from engine bay.



l. Remove MAF sensor from factory air box. The sensor and screws will be reused in step 3b.

3. Installation of AEM® intake system.

a. When installing the intake system, do not completely tighten the hose clamps or mounting hardware until

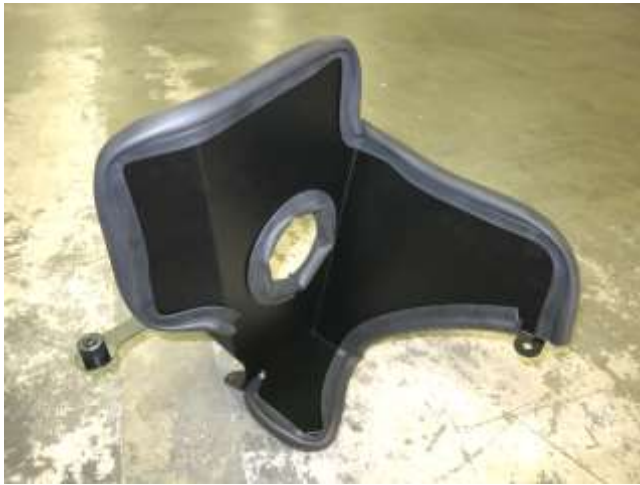

a. Prepare the AEM heatshield by applying edge trim and rubber grommet as shown. Edge trim will need to be trimmed to 36", 20" and 14" lengths.



b. Install MAF sensor and screws into the AEM intake tube that were removed in step 2l.



c. Install the supplied rubber isolator onto the air box mount behind the battery.



d. Install the AEM heatshield by inserting as shown and rotating counter-clockwise into position. Place a rubber washer between the heatshield and mounting location at inner fender mounting location as shown.



e. Using the supplied bolt, tighten heatshield mount at inner fender location ensuring the rubber washer is still in its location. Ensure other heatshield mounting hole lines up properly during tightening.



f. Using the supplied bolt and washer, tighten the heatshield mount behind the battery box.

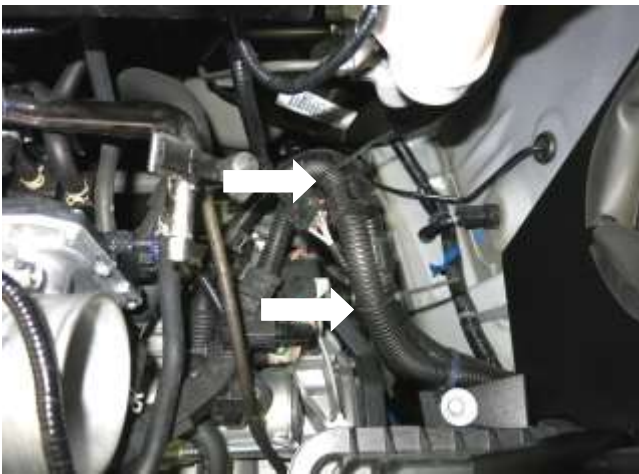

g. Using the two supplied zip ties, bundle wiring harnesses as shown in these locations. Clip excess zip tie lengths with diagonal cutters.



h. Install the supplied coupler and two smaller hose clamps onto the throttle body. Tighten the throttle body side coupler to 30 in-lbs at this time.



i. Install the provided vent hose onto the stock vent tube. Note: Warm soapy water may help installation.



j. Install the AEM intake tube into the heatshield by inserting it as shown and maneuvering it into place, aligning it with the coupler.



k. Install the vent hose onto the nipple on the AEM intake tube and insert the AEM intake tube into the coupler.



l. Position the AEM air filter into the engine bay as shown and maneuver it onto the AEM intake tube.



m. Tighten the hose clamp on the air filter to 30in-lbs.



n. Attach the sensor connector to the MAF sensor.



o. Reinstall the cold air duct and plastic pop-outs removed in step 2g. Note: Use care to not drop the clips as they are easily lost in the core support area. Position the AEM intake for best fit and tighten the hose clamp at the coupler to 30in-lbs at this time.



p. Reinstall the plastic core support cover by sliding it under the hood latch into position and gently pressing down, snapping it into place from left to right. Then, reinstall the plastic engine cover by aligning the rubber grommets with their posts and gently pressing down.



STOCK INTAKE INSTALLED



AEM INTAKE INSTALLED

4. Reassemble Vehicle (where applicable)

- a. Position all kit components for best fitment. Ensure that no components contact any unintended part of the vehicle.
- b. Check for proper hood clearance. Re-adjust components if necessary and re-tighten them.
- c. Inspect the engine bay for any loose tools and ensured that all fasteners that were moved or removed are properly tightened.
- d. Reconnect negative battery terminal and start engine. Let the vehicle idle for 3 minutes. Perform a final inspection before driving the vehicle.

5. Service and Maintenance (where applicable)

- a. AEM Induction Systems requires cleaning the intake system's air filter element every 100,000 miles. When used in dusty or off-road environments, our filters will require cleaning more often. We recommend that you visually inspect your filter once every 25,000 miles to determine if the screen is still visible. When the screen is no longer visible some place on the filter element, it is time to clean it. To clean, purchase our Synthetic air filter cleaner, part number 1-1000 and follow the easy instructions.
- b. Use window cleaner to clean your powder coated AEM[®] intake tube.

NOTE: DO NOT USE aluminum polish on powder coated AEM[®] intake tubes.

For technical inquiries
e-mail us at
sales@aemintakes.com
or
call us at
800.992.3000

AEM Air Intake System Warranty Policy

AEM® warrants that its intake systems will last for the life of your vehicle. AEM® will not honor this warranty due to mechanical damage (i.e. improper installation or fitment), damage from misuse, accidents or flying debris. AEM® will not warrant its powder coating if the finish has been cleaned with a hydrocarbon-based solvent. The powder coating should only be cleaned with a mild soap and water solution. Proof of purchase of both the vehicle and AEM® intake system is required for redemption of a warranty claim.

This warranty is limited to the repair or replacement of the AEM® part. In no event shall this warranty exceed the original purchase price of the AEM® part nor shall AEM® be responsible for special, incidental or consequential damages or cost incurred due to the failure of this product. Warranty claims to AEM® must be transportation prepaid and accompanied with dated proof of purchase. This warranty applies only to the original purchaser of product and is nontransferable. Improper use or installation, use for racing, accident, abuse, unauthorized repairs or alterations voids this warranty. AEM® disclaims any liability for consequential damages due to breach of any written or implied warranty on all products manufactured by AEM®. Warranty returns will only be accepted by AEM® when accompanied by a valid Return Merchandise Authorization (RMA) number. Credit for defective products will be issued pending inspection. Product must be received by AEM® within 30 days of the date RMA is issued.

If you have a warranty issue, please call (800) 992-3000 and our customer service department will assist you. A proof of purchase is required for all AEM® warranty claims.

Not legal for sale or use on any pollution controlled motor vehicle in California or states adopting California emission procedures. See AEMIntakes.com for CARB status on each part for a specific vehicle.