



INSTALLATION INSTRUCTIONS

21-865C

TOYOTA

2019 Corolla Hatchback

2020 Corolla

L4-2.0L

TOOLS NEEDED:

flat blade screw driver
ratchet
extension
phillips screw driver
3mm allen
4mm allen

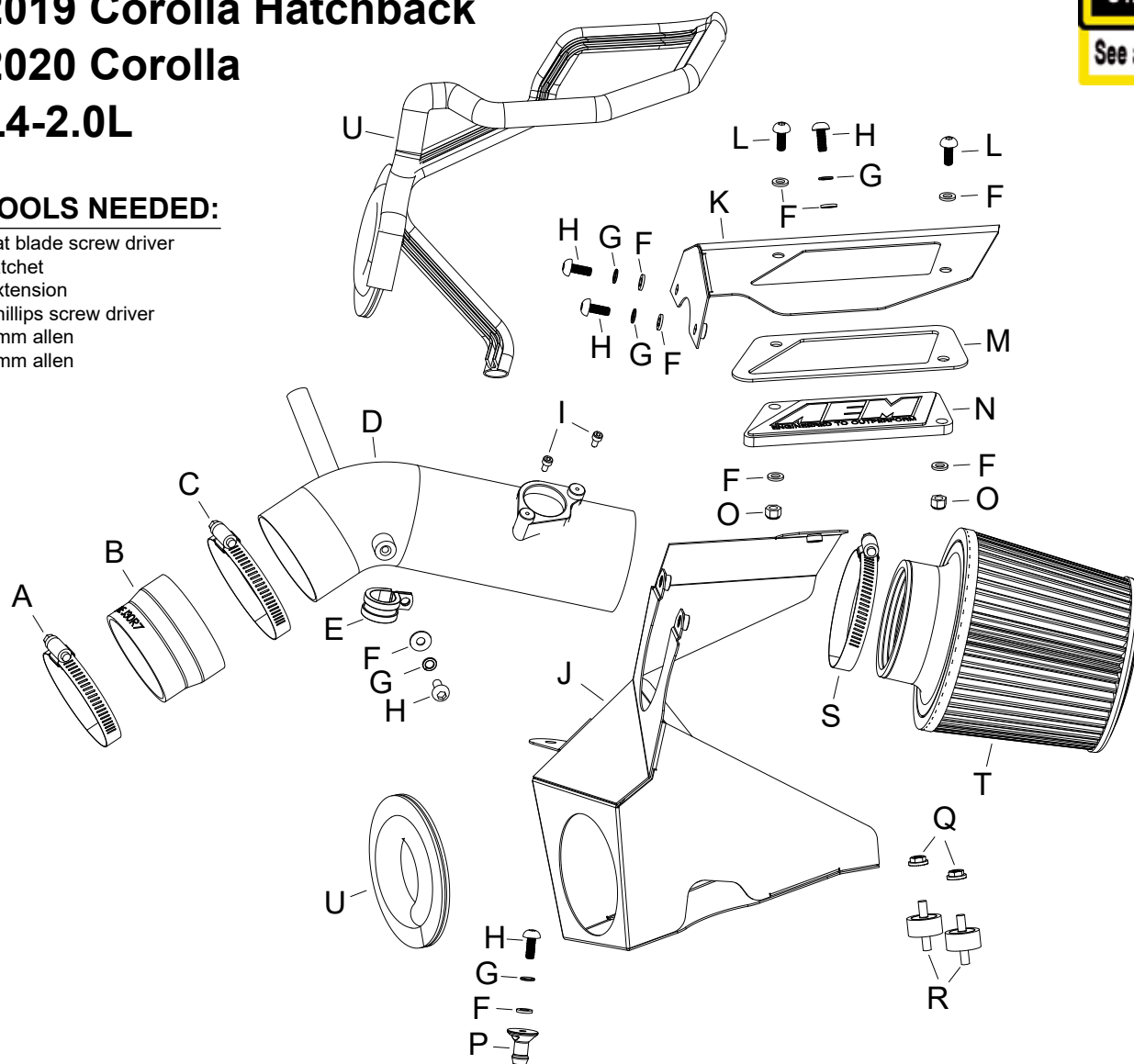

NOT LEGAL FOR SALE OR USE ON ANY POLLUTION CONTROLLED MOTOR VEHICLE IN CALIFORNIA OR STATES ADOPTING CALIFORNIA EMISSION PROCEDURES.

See aemintakes.com for CARB status on each part for a specific vehicle

PARTS LIST:

Description	Qty.	Part #
A HOSE CLAMP; #44	1	08577
B HOSE; 3" TO 2.75"ID X 2"L	1	084036
C HOSE CLAMP; #48	1	08601
D TUBE; 3"OD X 8", GUNMETAL	1	2-1635C
E CLAMP; LOOP, 3/4", RUBBER	1	077014
F WASHER; 6MM FLAT, SS	9	08269
G WASHER; M6 SPLIT LOCK ZINC	5	1-3025
H BOLT; M6 X 1.00" 12MM, SS	5	07794
I BOLT; M4-.7 X 8MM, ALLEN, SS	2	07733
J HEAT SHIELD, TB/PC	1	20-8652
K HEAT SHIELD; LID	1	20-8653
L SCREW; M6 X 20MM, BUTTON	2	KIT20BHC3060
M SPACER; ALUM CLEAR BADGE	1	7-364
N PLATE; AEM LOGO, CLEAR	1	8-211
O NUT; 6MM NYLOCK, HEXHEAD	2	07512
P MOUNT, PLASTIC AIRBOX	1	8-186-1
Q NUT; M6, HEX, SERRATED	2	444.460.04
R STUD; M6-1.00 M/M, RUBBER	2	07027
S 1/2" BNDHOSE CLAMP, 2.90"	1	9452
T AIR FILTER; 3" X 5" DRYFLOW	1	21-203DK
U EDGE TRIM; 3/4" BULB, TOP	1	102481

If you need any assistance please call 1-800-858-3333 to speak with a representative in our Customer Service Center before returning the product.

Read and understand these instructions **BEFORE** attempting to install this product. Failure to follow installation instructions and not using the provided hardware may damage the intake tube, throttle body and engine.

TO START:

1. Turn off the ignition and disconnect the negative battery cable.

NOTE: Disconnecting the negative battery cable erases pre-programmed electronic memories. Write down all memory settings before disconnecting the negative battery cable. Some radios will require an anti-theft code to be entered after the battery is reconnected. The anti-theft code is typically supplied with your owner's manual. In the event your vehicles anti-theft code cannot be recovered, contact an authorized dealership to obtain your vehicles anti-theft code.



2. Disconnect the mass air sensor electrical connection.



3. Disconnect the EVAP solenoid and bracket from the factory intake tube.



4. Loosen the hose clamp that secures the intake tube to the throttle body.



5. Remove the PCV hose from the factory intake tube and then loosen the hose clamp that secures the intake hose to the air filter housing and then remove it from the vehicle.



6. Release the two clips that secure the upper air filter housing and then remove the upper housing from the vehicle.



7. Remove the two bolts that secure the lower air filter housing and then remove the housing from the vehicle.



8. Install the two provided rubber mounted studs into the frame at the factory air filter housing mounting locations.

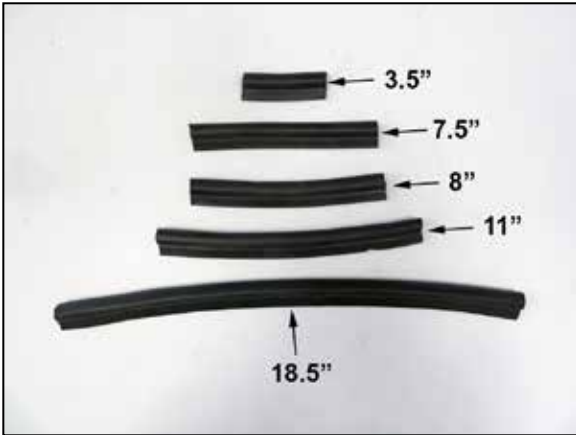

9. Cut the edge trim into sections of 3.5\", 7.5\", 8\", 11\" and 18.5\".



10. Install the AEM® window and 18.5\" edge trim onto the heat shield lid as shown.



11. Install the 3.5\" edge trim onto the bottom of the heat shield lid as shown.

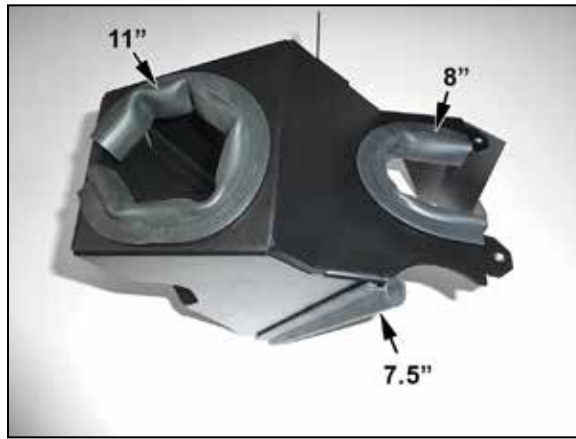

12. Install the 7.5\", 8\" and 11\" edge trim onto the heat shield as shown.



13. Install the mounting stud onto the heat shield using the provided hardware as shown.



14. Remove the factory fresh air intake duct from the factory air filter housing.



15. Install the fresh air intake duct into the hole of the heat shield as shown.



16. Install the heat shield assembly and align the fresh air intake duct. Secure the assembly with the provided hardware.



17. Remove the mass air sensor from the factory air filter housing and then install it into the AEM® intake tube and secure with the hardware provided.



18. Install the provided loop clamp onto the AEM® intake tube and secure with the provided hardware.



19. Install the AEM® air filter onto the intake tube and secure with the provided hardware.



20. Install the provided coupler (084036) onto the throttle body and secure with the provided hose clamp.



21. Install the intake tube assembly into the coupler at the throttle body and adjust for best fit.



22. Connect the PCV hose to the AEM® intake tube and secure with the factory spring clamp.



23. Insert the EVAP solenoid bracket into the adel clamp attached to the intake tube.



24. Install the heat shield lid and secure with the provided hardware.



25. Reconnect the mass air electrical connection.



Reassemble Vehicle

Position the inlet pipes for the best fitment. Be sure that the pipes or any other components do not contact any part of the vehicle. Tighten the rubber mount, all bolts, and hose clamps. Check for proper hood clearance. Re-adjust pipes if necessary and re-tighten them. Inspect the engine bay for any loose tools and check that all fasteners that were moved or removed are properly tightened. Reconnect negative battery terminal and start engine. Let the vehicle idle for 3 minutes. Perform a final inspection before driving the vehicle.

Service and Maintenance

AEM Induction Systems requires cleaning the intake system's air filter element every 100,000 miles. When used in dusty or off-road environments, our filters will require cleaning more often. We recommend that you visually inspect your filter once every 25,000 miles to determine if the screen is still visible. When the screen is no longer visible some place on the filter element, it is time to clean it. To clean, purchase our Synthetic air filter cleaner, part number 99-0624 and follow the easy instructions. Use window cleaner to clean your powder coated AEM® intake tube.

NOTE: DO NOT USE aluminum polish on powder coated AEM® intake tubes.

NOT LEGAL FOR SALE OR USE ON ANY POLLUTION CONTROLLED MOTOR VEHICLE IN CALIFORNIA OR STATES ADOPTING CALIFORNIA EMISSION PROCEDURES.

See aemintakes.com for CARB status on each part for a specific vehicle

AEM Air Intake System Warranty Policy

AEM® warrants that its intake systems will last for the life of your vehicle. AEM will not honor this warranty due to mechanical damage (i.e. improper installation or fitment), damage from misuse, accidents or flying debris. AEM will not warrant its powder coating if the finish has been cleaned with a hydrocarbon-based solvent. The powder coating should only be cleaned with a mild soap and water solution. Proof of purchase of both the vehicle and AEM intake system is required for redemption of a warranty claim.

This warranty is limited to the repair or replacement of the AEM part. In no event shall this warranty exceed the original purchase price of the AEM part nor shall AEM be responsible for special, incidental or consequential damages or cost incurred due to the failure of this product. Warranty claims to AEM must be transportation prepaid and accompanied with dated proof of purchase. This warranty applies only to the original purchaser of product and is nontransferable. Improper use or installation, use for racing, accident, abuse, unauthorized repairs or alterations voids this warranty. AEM disclaims any liability for consequential damages due to breach of any written or implied warranty on all products manufactured by AEM. Warranty returns will only be accepted by AEM when accompanied by a valid Return Merchandise Authorization (RMA) number. Credit for defective products will be issued pending inspection. Product must be received by AEM within 30 days of the date RMA is issued.

If you have a warranty issue, please call (800) 992-3000 and our customer service department will assist you. A proof of purchase is required for all AEM warranty claims.