

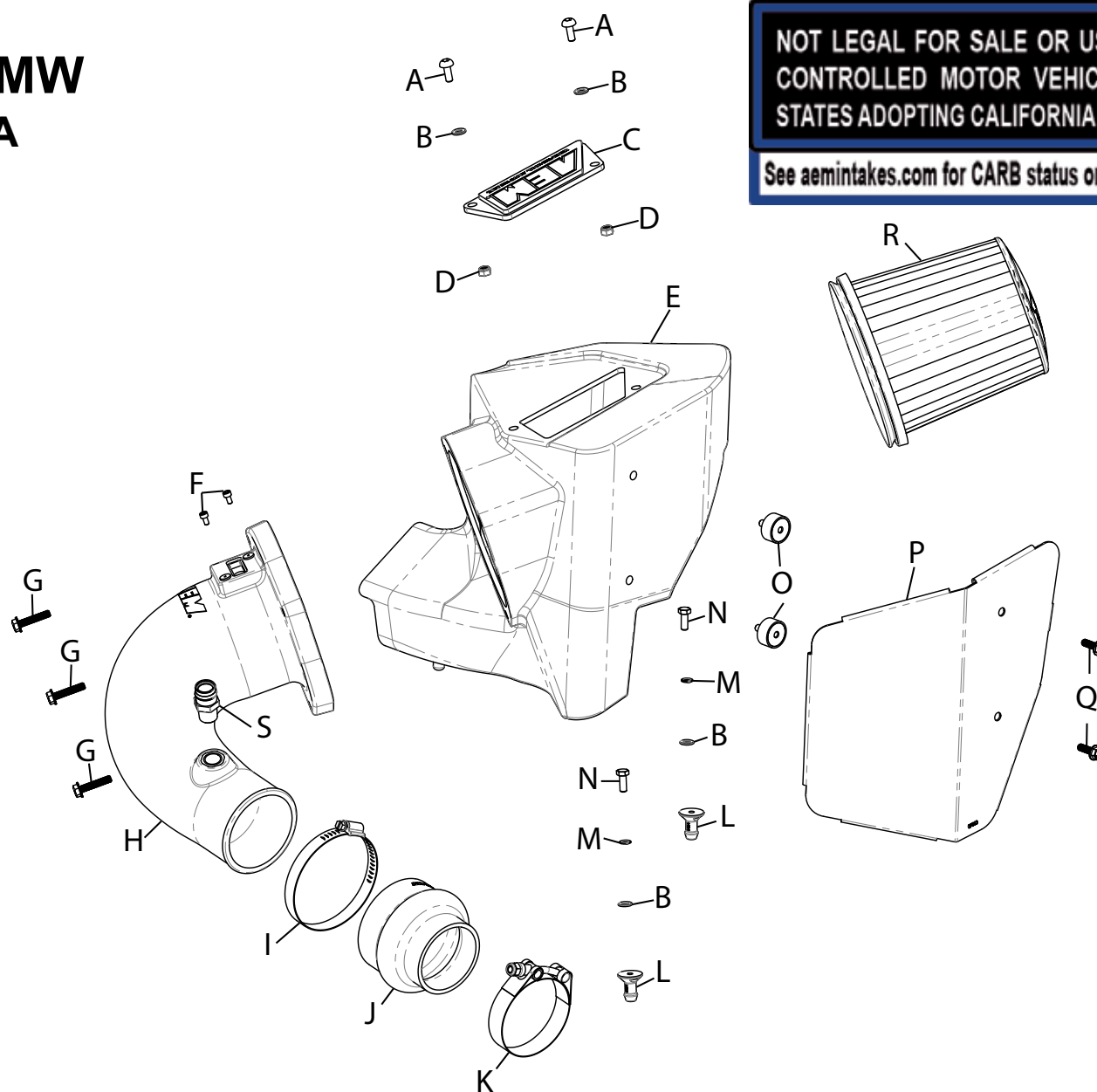

## INTAKE SYSTEM

# INSTALLATION INSTRUCTIONS

**21-882DS**  
**TOYOTA / BMW**  
**2020-22 SUPRA**  
**L4-2.0L**  
**2020-22 Z4**  
**L4-2.0L**



**NOT LEGAL FOR SALE OR USE ON ANY POLLUTION CONTROLLED MOTOR VEHICLE IN CALIFORNIA OR STATES ADOPTING CALIFORNIA EMISSION PROCEDURES.**  
 See [aemintakes.com](http://aemintakes.com) for CARB status on each part for a specific vehicle

### TOOLS NEEDED:

- Phillips screw driver
- Flat blade screw driver
- Ratchet
- Extension
- 10mm socket
- 3mm allen key
- 4mm allen key
- adjustable wrench
- thread sealer

### PARTS LIST:

Description	Qty.	Part #	Description	Qty.	Part #	Description	Qty.	Part #
A BOLT; M6 X 1 X 16MM	2	07730	H TUBE; (PU)	1	087525	O STUD; RUBBER 1/2"L X 1"W	2	070228
B WASHER; 6MM FLAT	4	08269	I HOSE CLAMP; #52	1	08610	P HEAT SHIELD	1	07380
C PLATE; AEM LOGO CLEAR	1	8-211-1	J HOSE; HUMP 2.5"ID X 3.25"ID	1	084121	Q BOLT; M6-1 X 12	2	1-2110
D NUT; 6MM NYLOCK	2	07553	K HOSE CLAMP; #44	1	08560	R AIR FILTER	1	21-1016DK
E AIRBOX (NV)	1	087463	L MOUNT; PLASTIC AIRBOX	2	8-186-1	S FITTING; 3/4"OD X 1.12"L	1	82934
F BOLT; M4-.7 X 8MM	2	07733	M WASHER; M6 SPLIT LOCK	2	1-3025			
G BOLT; M6-1 X 30	3	1-1016	N BOLT; M6-1 X 16MM	2	07812			

**If you need any assistance please call 1-800-858-3333 to speak with a representative in our Customer Service Center before returning the product.**

**Read and understand these instructions BEFORE attempting to install this product. Failure to follow installation instructions and not using the provided hardware may damage the intake tube, throttle body and engine.**

### TO START:

1. Turn off the ignition and disconnect the negative battery cable.  
**NOTE: Disconnecting the negative battery cable erases pre-programmed electronic memories. Write down all memory settings before disconnecting the negative battery cable. Some radios will require an anti-theft code to be entered after the battery is reconnected. The anti-theft code is typically supplied with your owner's manual. In the event your vehicles anti-theft code cannot be recovered, contact an authorized dealership to obtain your vehicles anti-theft code.**



2. Disconnect the temperature sensor electrical connection. Loosen the hose clamp connecting the intake tube to the factory air filter housing, separate the tube from the housing. Lift the air filter housing up and remove it from the vehicle.



3. Pinch the locking tabs on the CCV hose connection and then disconnect the CCV hose from the factory intake tube.



4. Remove the clip that locks the intake tube to the turbo inlet and then disconnect the tube from the turbo and remove it from the vehicle.



5. Install the provided mounting studs onto the AEM air filter housing using the provided hardware.



6. Install the AEM window into the air filter housing using the provided hardware.



7. Install the two rubber mounted studs onto the AEM air filter housing using the provided hardware.

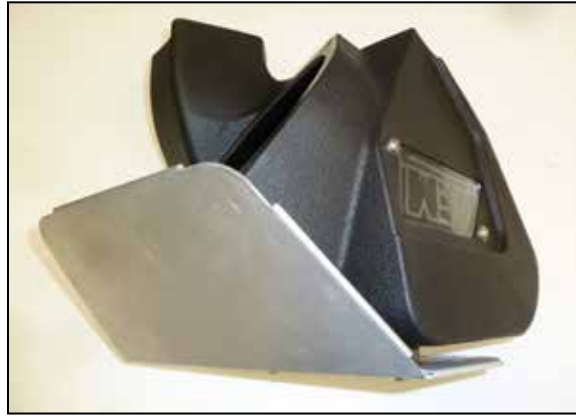

8. Install the heat shield onto the rubber mounted studs using the provided hardware.



9. Install the provided CCV fitting into the AEM intake tube. Be sure to apply thread sealer before installing the fitting into the intake tube.



10. Remove the sensor from the factory intake tube. Install the sensor into the intake tube using the provided hardware.



11. Place the air filter into the AEM air filter housing.



12. Install the AEM tube onto the filter housing and secure with the provided hardware.



13. Install the provided coupler onto the turbo inlet.



14. Install the assembly into the vehicle so the intake tube engages the coupler and the mounting studs engage the mounting grommets. Tighten hose clamp.



15. Connect the CCV hose to the fitting installed into the intake tube.



16. Reconnect the sensor electrical connection.



### Reassemble Vehicle

Position the inlet pipes for the best fitment. Be sure that the pipes or any other components do not contact any part of the vehicle. Tighten the rubber mount, all bolts, and hose clamps. Check for proper hood clearance. Re-adjust pipes if necessary and re-tighten them. Inspect the engine bay for any loose tools and check that all fasteners that were moved or removed are properly tightened. Reconnect negative battery terminal and start engine. Let the vehicle idle for 3 minutes. Perform a final inspection before driving the vehicle.

### Service and Maintenance

AEM Induction Systems requires cleaning the intake system's air filter element every 100,000 miles. When used in dusty or off-road environments, our filters will require cleaning more often. We recommend that you visually inspect your filter once every 25,000 miles to determine if the screen is still visible. When the screen is no longer visible some place on the filter element, it is time to clean it. To clean, purchase our Synthetic air filter cleaner, part number AEM-1-1000 and follow the easy instructions. Use window cleaner to clean your powder coated AEM® intake tube.

**NOTE: DO NOT USE aluminum polish on powder coated AEM® intake tubes.**

NOT LEGAL FOR SALE OR USE ON ANY POLLUTION CONTROLLED MOTOR VEHICLE IN CALIFORNIA OR STATES ADOPTING CALIFORNIA EMISSION PROCEDURES.

See [aemintakes.com](http://aemintakes.com) for CARB status on each part for a specific vehicle

### AEM Air Intake System Warranty Policy

AEM® warrants that its intake systems will last for the life of your vehicle. AEM will not honor this warranty due to mechanical damage (i.e. improper installation or fitment), damage from misuse, accidents or flying debris. AEM will not warrant its powder coating if the finish has been cleaned with a hydrocarbon-based solvent. The powder coating should only be cleaned with a mild soap and water solution. Proof of purchase of both the vehicle and AEM intake system is required for redemption of a warranty claim.

This warranty is limited to the repair or replacement of the AEM part. In no event shall this warranty exceed the original purchase price of the AEM part nor shall AEM be responsible for special, incidental or consequential damages or cost incurred due to the failure of this product. Warranty claims to AEM must be transportation prepaid and accompanied with dated proof of purchase. This warranty applies only to the original purchaser of product and is nontransferable. Improper use or installation, use for racing, accident, abuse, unauthorized repairs or alterations voids this warranty. AEM disclaims any liability for consequential damages due to breach of any written or implied warranty on all products manufactured by AEM. Warranty returns will only be accepted by AEM when accompanied by a valid Return Merchandise Authorization (RMA) number. Credit for defective products will be issued pending inspection. Product must be received by AEM within 30 days of the date RMA is issued.

If you have a warranty issue, please call (800) 992-3000 and our customer service department will assist you. A proof of purchase is required for all AEM warranty claims.