



**INFINITI Q50/Q60**

# ALPHA AIR BOXES

---

By letting the turbos ingest all the cold air they need, the Q60 and Q50 Red Alpha Performance Intake System when combined with the other Q60 and Q50 Red Alpha components boosts power significantly.

ALPHA

# Table of Contents

PAGE	<b>03</b>	Introduction
PAGE	<b>04</b>	Disassembly Guide
PAGE	<b>05</b>	Passenger's Side Air Box Installation
PAGE	<b>15</b>	Driver's Side Air Box Installation
PAGE	<b>20</b>	Adjustment & Panel Re-Installation
PAGE	<b>21</b>	Alpha Filter Cleaning

# Introduction

The goal of Alpha Performance is to provide the highest quality, best performing products available. By utilizing research and development, and rigorous testing programs Alpha Performance will never compromise the quality or performance of our products. In addition, Alpha Performance will only provide the finest customer service offering only parts and advice that are in the best interests of the customer. Alpha Performance was built on a foundation of integrity. This is who we are; this is what you can count on.

A vehicle modified by the use of performance parts may not meet the legal requirements for use on public roads. Federal and state laws prohibit the removal, modification, or rendering inoperative of any part or element of design affecting emissions or safety on motor vehicles used for transporting persons or property on public streets or highways. Use or installation of performance parts may adversely affect the drivability and reliability of your vehicle, and may also affect or eliminate your insurance coverage, factory warranty, and/or new OEM part warranty. Performance parts are sold as-is without any warranty of any type. There is no warranty stated or implied due to the stresses placed on your vehicle by performance parts and our inability to monitor their use, tuning, or modification.

These instructions are provided as a guide only as there are many variables that cannot be accounted for concerning your particular vehicle, including but not limited to model year differences, model differences, the presence of non-OEM parts, and modifications that may already be or were previously installed. A basic knowledge of automotive parts and systems is helpful but a better understanding of the parts and systems on your particular vehicle may be required.

If you have any questions or issues at any time during the installation of your Alpha Performance product(s) please call us for technical assistance. The Alpha Performance tech line can be reached during business hours at 847-709-0530 for Alpha Performance products only.



## Dissassembly

01. Start by removing both the brake master and battery cowl covers.



02. Remove both plastic fender trim panels. These panels can be difficult to remove due to the plastic clips. The clips under the panels run along the fender edge. In order to remove these panels without breaking the clips, lift straight upwards starting at the front by the head light and work backwards.

- a. The trick is to place a finger through the headlight adjustment hole and washer fill hole while supporting the edge by the hood latches. Lift straight upwards while wiggling the panel in the different directions. A circular wiggle motion is the most effective. Once the main clip closest to the headlight is disconnected, the rest of the clips release easily.



03. Remove the front air box inlet / core support cover. Take note of the different style clips as they are specific to the location installed. There will be six (3 prong) along the front bumper and then two (4 prong) clips close to the air boxes.

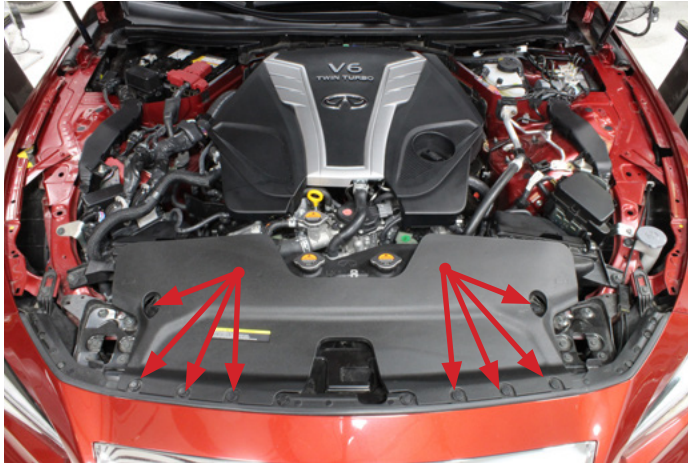

## Right Side OEM Air Box Installation (Passenger)

04. Remove the two M6 bolts from the front air box mounting brackets. Unclip the front portion and remove it along with the filter.

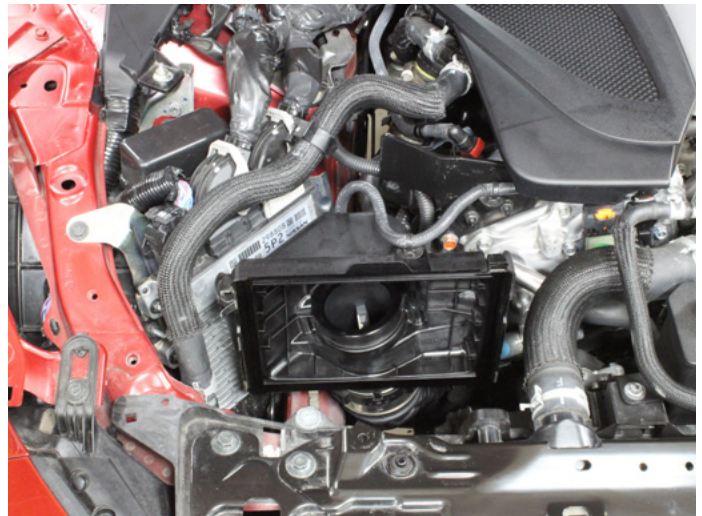

05. Disconnect the MAF sensor and unclip the harness from the top and rear side of the air box.

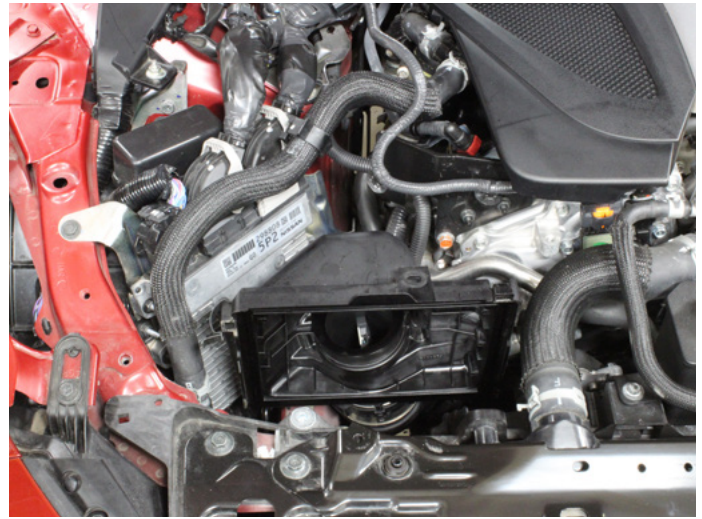
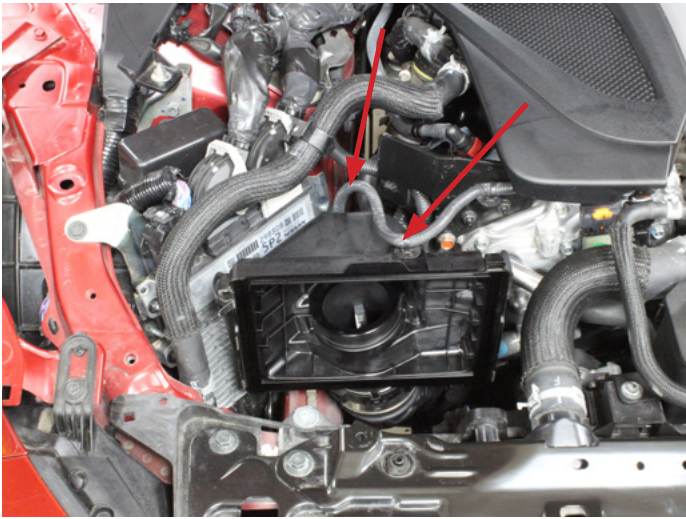

06. Disconnect the OEM coupler from the rear section of the air box and remove the air box.

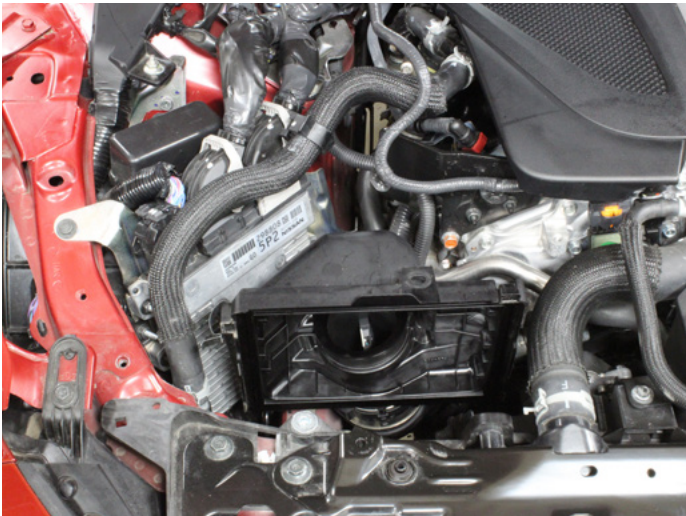

**Tech Note:** The OEM coupler has a double retention method. In order to disconnect, you must do two things. First place a hand on the coupler and force it towards the MAF housing and air box. This moves the retention ring out of the locked area to allow it to disconnect. Next, while still forcing the coupler against the MAF housing and air box, use a long flat head screw driver and release the retention clip. The retention clip will sit in detents when properly released. Remove the air box once disconnected. (The below pictures were taken off the car to better show the process)

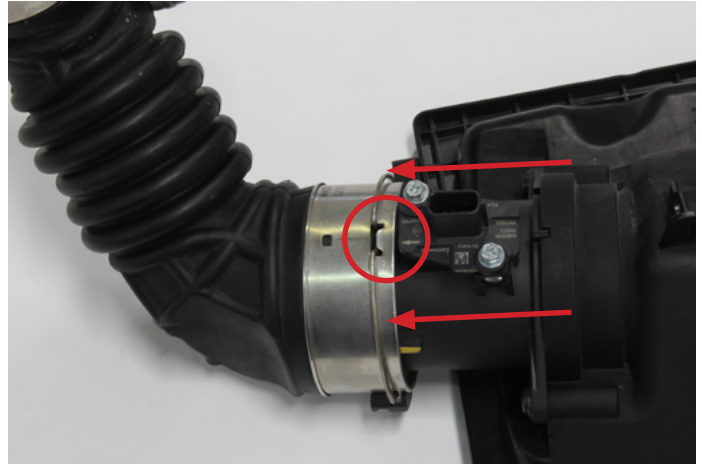

07. Disconnect the coupler from the turbo inlet. The hose clamp is a little difficult to get to but can be done with a small 8mm ratchet and socket or a long extension and a swivel 8mm socket. Once disconnected, pull the coupler forwards.

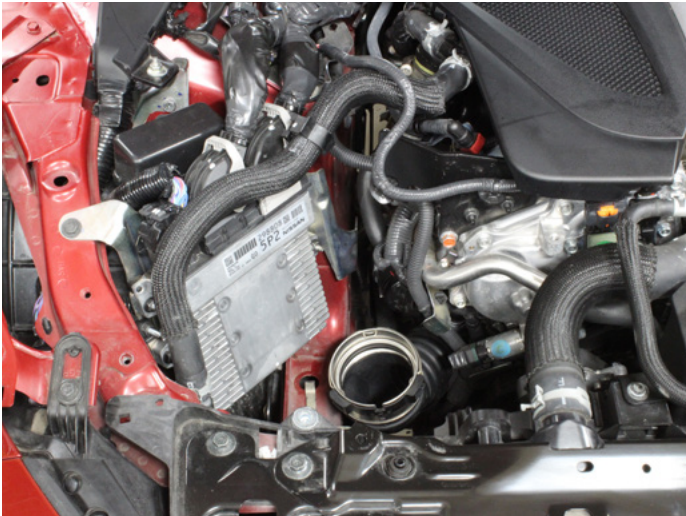

08. Disconnect the PCV hose from the OEM coupler. Only disconnect the small clamp at this time. Completely remove the OEM coupler.





09. For the right side only (Passenger Side), remove the OEM air box support bracket. Remove the rubber grommet from the bracket and reinstall it on the open hole on the frame rail as shown. Use a little silicone spray or available lube on the grommet to aid installation.

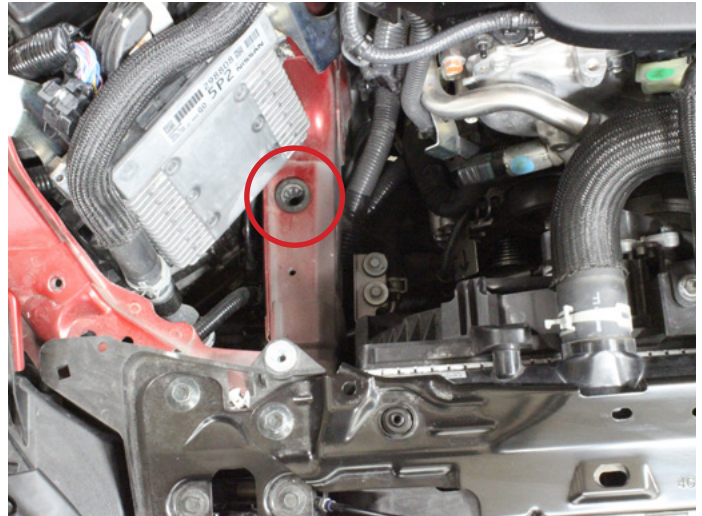
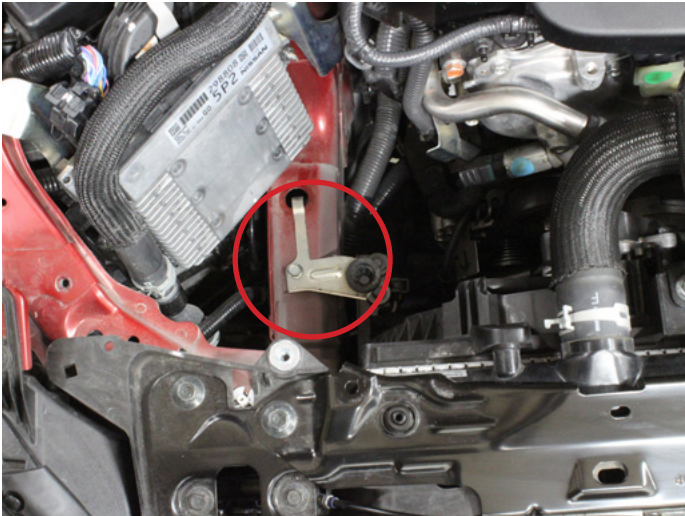

10. Remove the MAF housing from the rear section of the OEM air box. The Phillips head screws and O-ring will not be reused.



11. Locate the Pem style nut in the hardware kit. It is a press in type nut that will aid in installing the intake boxes. Orientate the MAF housing as shown in the second photo below and press the nut into the MAF housing using a pair of pliers. Make sure the nut is pressed in straight and is fully installed.

**NOTES:** *If for some reason the Pem nut will not remain in place in the MAF housing, a standard M6 nut can be used and will be installed in a later step.*



**TECH NOTES:** *Pem nuts are often referred to as clinch style captive nuts. They press into a drilled or punched hole with an arbor press or similar pressure tool. In this case, as we're installing it into a plastic material, a pair of pliers will do the trick. Below is a close up of the Pem nut supplied. You can see the knurled area that is slightly tapered. This will lock the nut in place after it is pressed into the MAF housing.*



12. Locate the longer of the two silicone couplers with the small port on the top. Also locate one #48 and one #32 hose clamp. Place the #48 hose clamp on the silicone and install the silicone coupler as shown. Align the tab on the MAF housing with the notch in the silicone coupler. Center the tab in the notch. Note the direction and location of the hose clamp's worm gear so you will be able to access the clamp once it is installed in the vehicle.

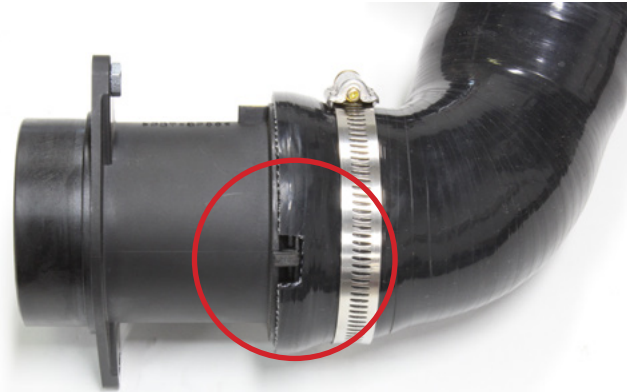

13. Once the silicone is installed on the MAF housing, tighten the #48 hose clamp as shown in the first picture below. The worm gear will align on the side of the MAF housing with the Pem nut. Loosely install the #32 hose clamp on the smaller end in the orientation shown.

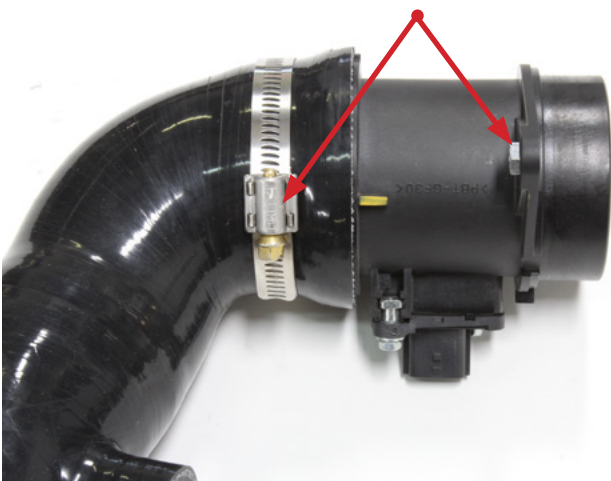

14. Remove the plastic barb from the OEM coupler and transfer it to the silicone coupler. Use the #10 hose clamp provided in the hardware kit. Align the hose clamp exactly as shown.

**NOTES:** It may be possible to reuse the OEM spring clamp for the plastic barb that is being transferred to the silicone depending on the thickness of the silicone in this area.



15. Install the silicone coupler in the car. First attach the PCV vent hose using the smaller OEM clamp. Then fully install the coupler onto the turbo inlet. Do not tighten the hose clamp yet.

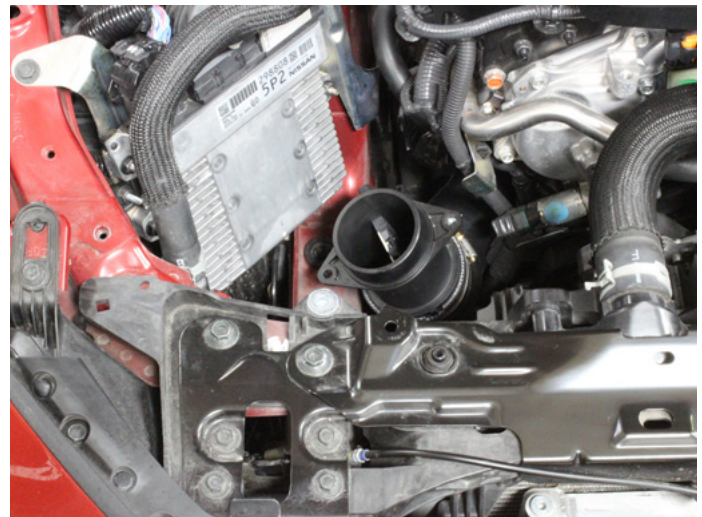
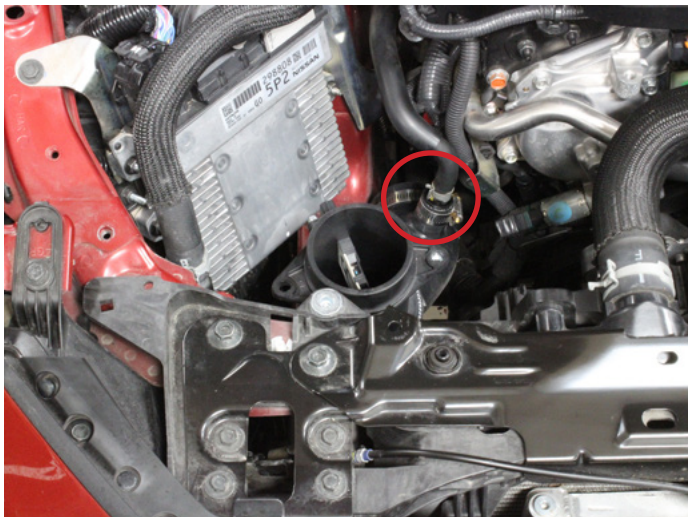

16. Locate the stainless steel air box support brackets and aluminum ball studs. These parts are mirrors of each other and can be easily mixed up but can only be installed one way. The pictures below show the orientation and what side they both go on. Install the aluminum ball studs as shown below and make sure to not over tighten them. They are only to be snugged down. Over tightening will cause the aluminum studs to break.



17. Place the right side (Passenger) bracket into the rubber grommet that was moved in step #9 as shown. The top of the support bracket will sit just under the MAF housing mounting ear. Clock the silicone coupler and MAF housing so that the bracket perfectly aligns with the mounting ear. At this point, tighten the #32 hose clamp on the turbo inlet locking the coupler in place.

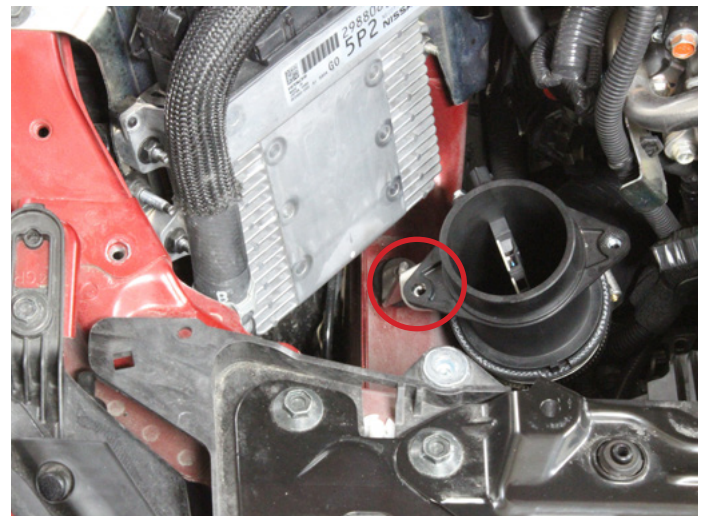
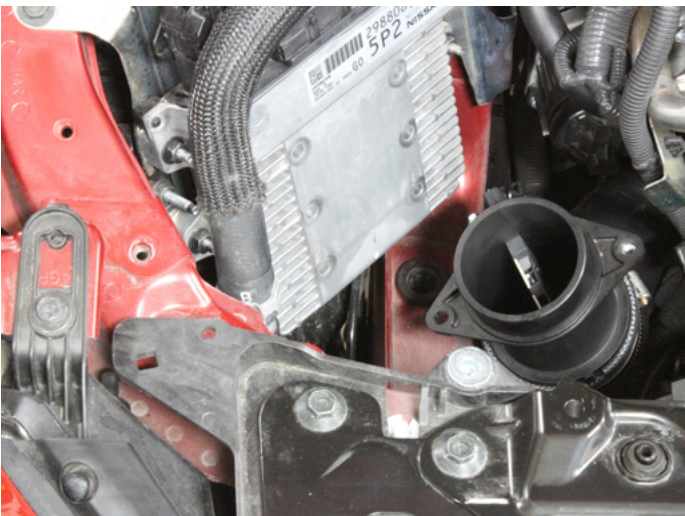

18. Locate the right side (Passenger) lower air box and two of the longer stainless steel M6 button head bolts. Install the lower air box on the MAF housing making sure the alignment tab on the MAF housing aligns with the notch in the bottom of the air box. Install the bolts making sure not to press out the Pem nut installed in the MAF housing. There is a welded nut on the bracket support side. Reconnect the MAF harness connector now as it will be difficult to get to after the upper air box lid is installed.

**NOTES:** If the Pem nut is having issues staying in place for some reason, you may have to support it from the back side while installing the bolt or you may use a standard M6 nut.

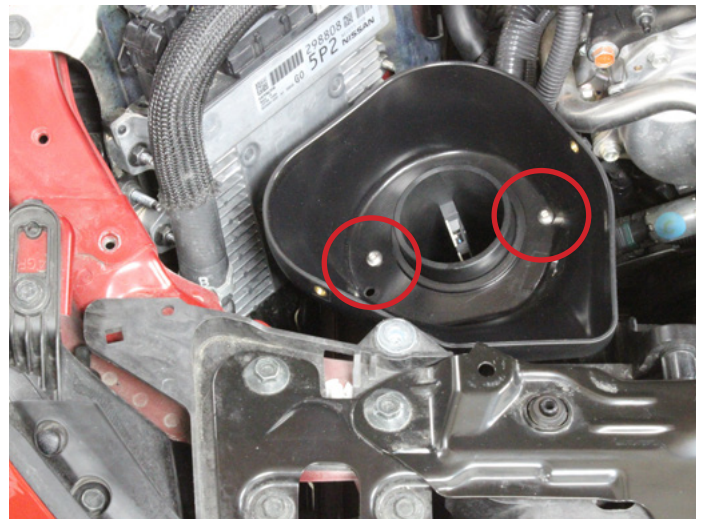
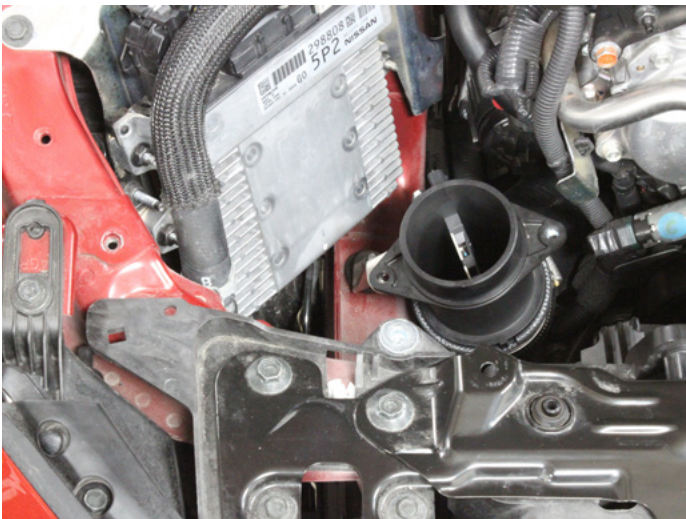

19. Install the air filter onto the MAF housing. The lower air box has a hole in the side to be able to tighten the clamp on the filter. Make sure the air filter is fully seated on to the MAF and align the clamp to the hole. Use a small screw driver or small socket and extension to tighten the clamp through this hole. After installing the air filter, locate one of the plastic caps in the hardware kit and install it into the open hole. It may take a little bit of force to fully seat the plastic cap since the surface is not perfectly flat.

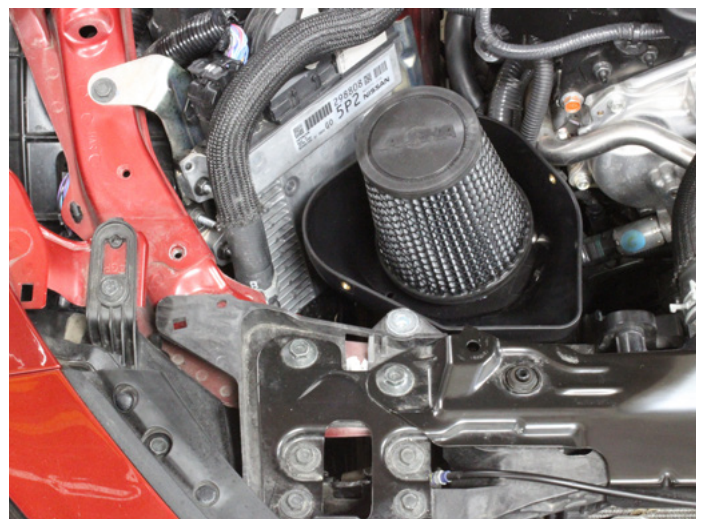

20. Locate the upper air box lid and two of the short stainless steel M6 button head bolts. Remove the rubber mounting grommets from the OEM air box. Do so by removing the metal sleeve in the grommet first then the grommet itself. Reinstall the grommets into the Alpha upper air box in the reverse order, grommet first then the metal sleeve second. Install the upper lid and install the two shorter M6 bolts making sure to not over tighten them. Lastly, reinstall the OEM M6 mounting bolts and center the bolt within the grommet.

**NOTES:** Over tightening the short M6 bolts that hold together the upper and lower sections of the air box can lead to insert damage, seized bolts, or pulling the insert out completely.



## Left Side Air Box Installation (Driver's Side)

21. Remove the two M6 bolts from the front air box mounting brackets. Unclip the front portion and remove it along with the filter.

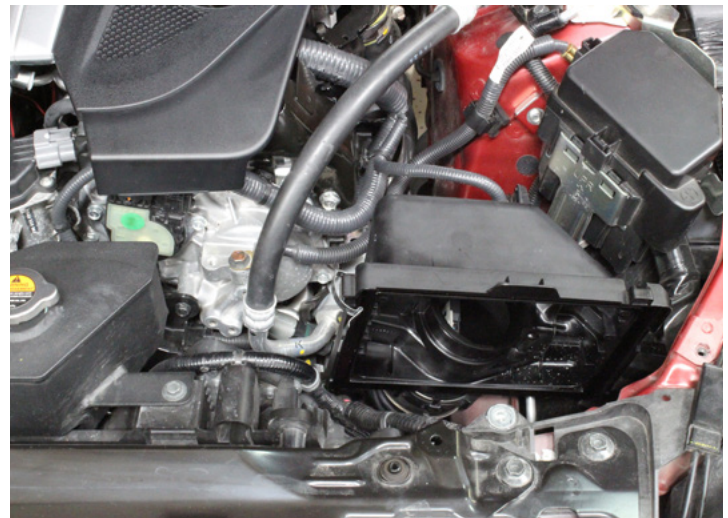
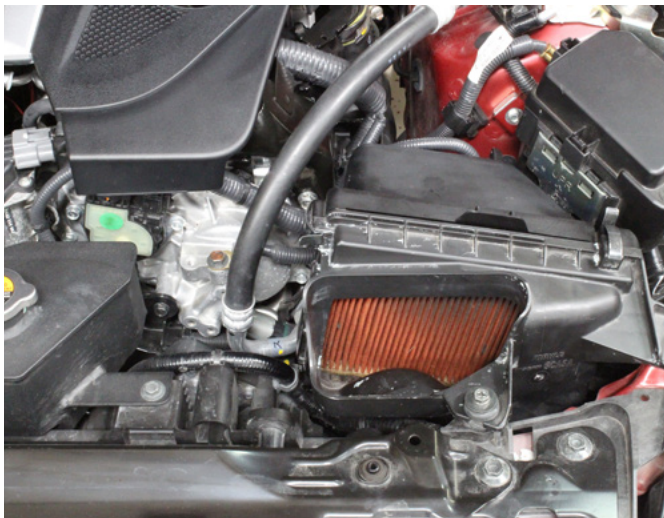

22. Disconnect the MAF harness and connector from the air box. Loosen the hose clamp on the OEM coupler at the turbo inlet. The coupler and rear section of the air box can be removed together on this side. Remove the assembly and remove the MAF housing from the OEM air box as was done in step #10 for the right side (Passenger).

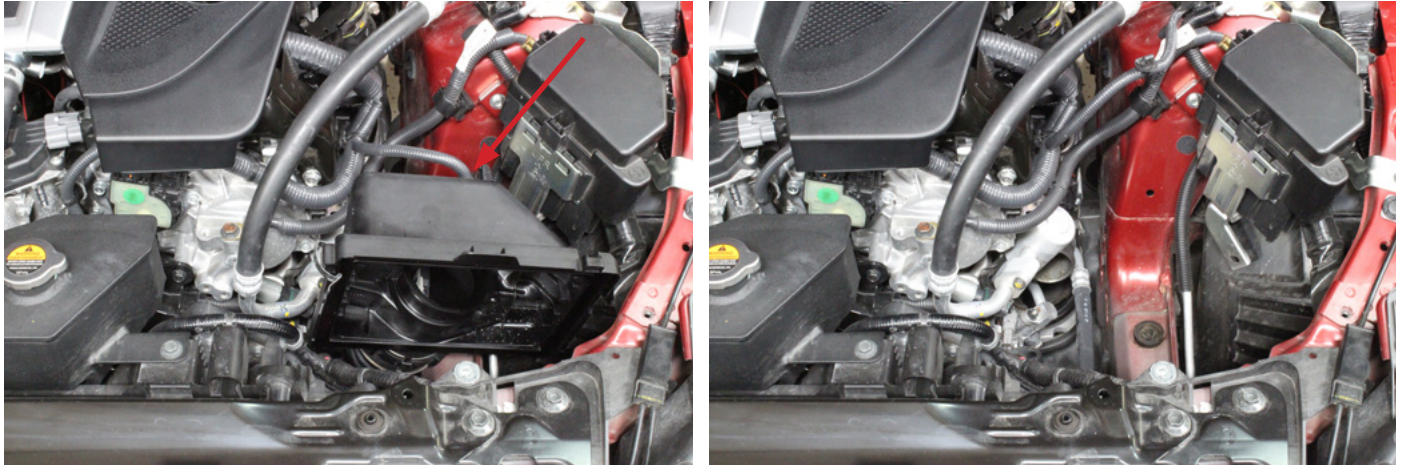

23. Locate the last remaining Pem style nut in the hardware kit. It is a press in type nut that will aid in installing the intake boxes. Orientate the MAF housing as shown in the second photo below and press the nut into the MAF housing using a pair of pliers. Make sure the nut is pressed in straight and is fully installed.

**NOTES:** If for some reason the Pem nut will not remain in place in the MAF housing, a standard M6 nut can be used and will be installed in a later step.





24. Locate the shorter of the two silicone couplers. Also locate the last #48 and #32 hose clamp. Place the #48 hose clamp on the silicone and install the silicone coupler as shown. Align the tab on the MAF housing with the notch in the silicone coupler. Center the tab in the notch. Note the direction and location of the hose clamp's worm gear so you will be able to access the clamp once it is installed in the vehicle.



25. Once the silicone is installed on the MAF housing, tighten the #48 hose clamp as shown in the first picture below. The worm gear will align on the side of the MAF housing with the Pem nut. Loosely install the #32 hose clamp on the smaller end in the orientation shown.



26. Install the silicone coupler in the car. Do not tighten the hose clamp yet.

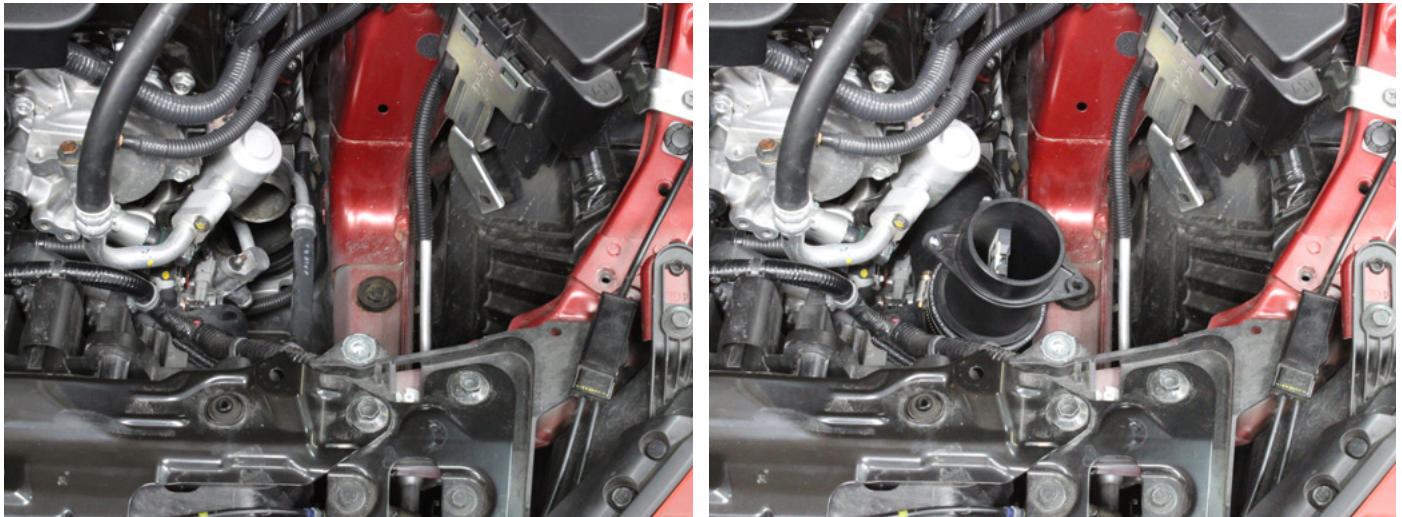

27. Place the left side (Driver) bracket into the rubber grommet on the frame rail. The top of the support bracket will sit just under the MAF housing mounting ear. Clock the silicone coupler and MAF housing so that the bracket perfectly aligns with the mounting ear. At this point, tighten the #32 hose clamp on the turbo inlet locking the coupler in place.

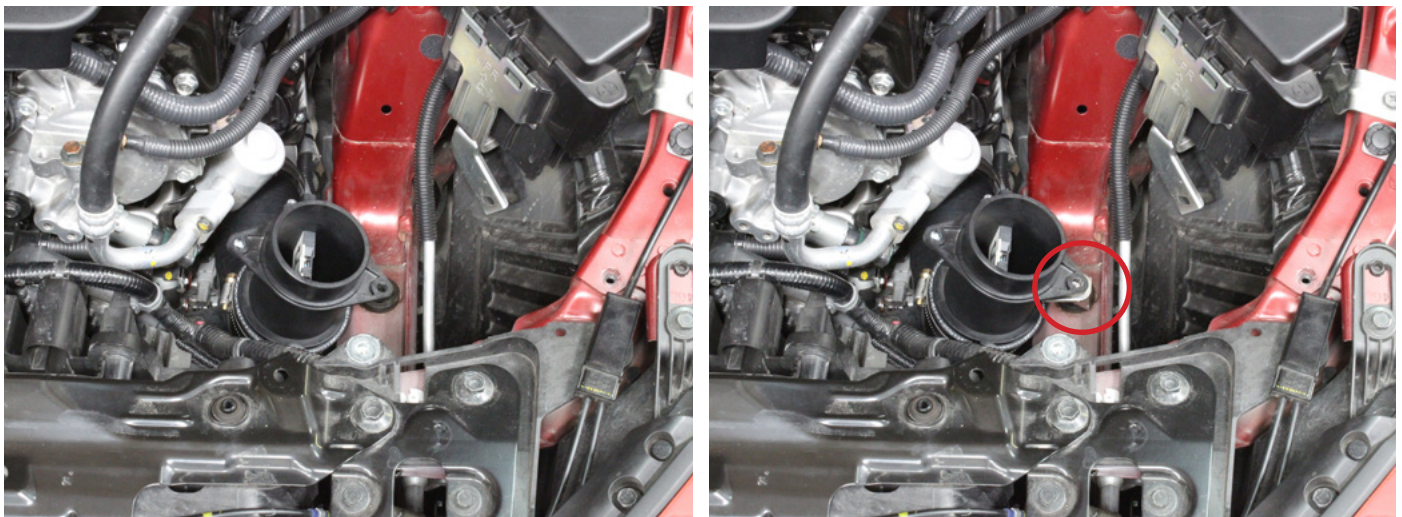

28. Locate the left side (Driver) lower air box and two of the longer stainless steel M6 button head bolts. Install the lower air box on the MAF housing making sure the alignment tab on the MAF housing aligns with the notch in the bottom of the air box. Install the bolts making sure not to press out the Pem nut installed in the MAF housing. There is a welded nut on the bracket support side. Reconnect the MAF harness connector now as it will be difficult to get to after the upper air box lid is installed.

**NOTES:** If the Pem nut is having issues staying in place for some reason, you may have to support it from the back side while installing the bolt or you may use a standard M6 nut.

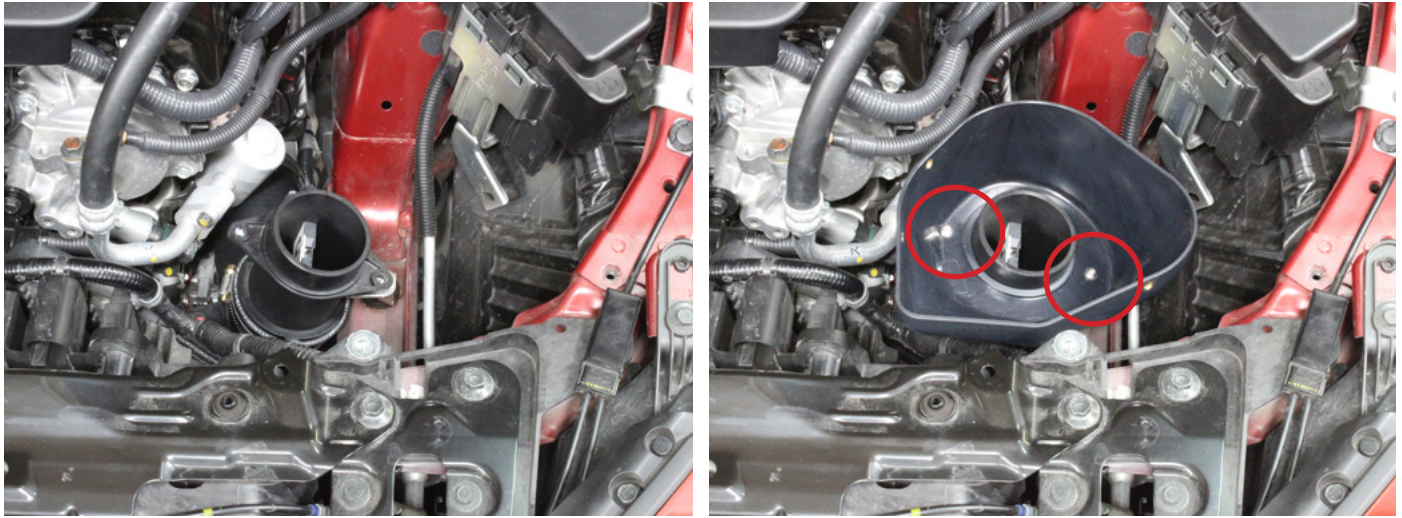

29. Install the air filter onto the MAF housing. The lower air box has a hole in the side to be able to tighten the clamp on the filter. Make sure the air filter is fully seated on the MAF housing and align the clamp gear to the access hole. Use a small screw driver or small socket and extension to tighten the clamp through this hole. After installing the air filter, locate one of the plastic caps in the hardware kit and install it into the open hole. It may take a little bit of force to fully seat the plastic cap since the surface is not perfectly flat.

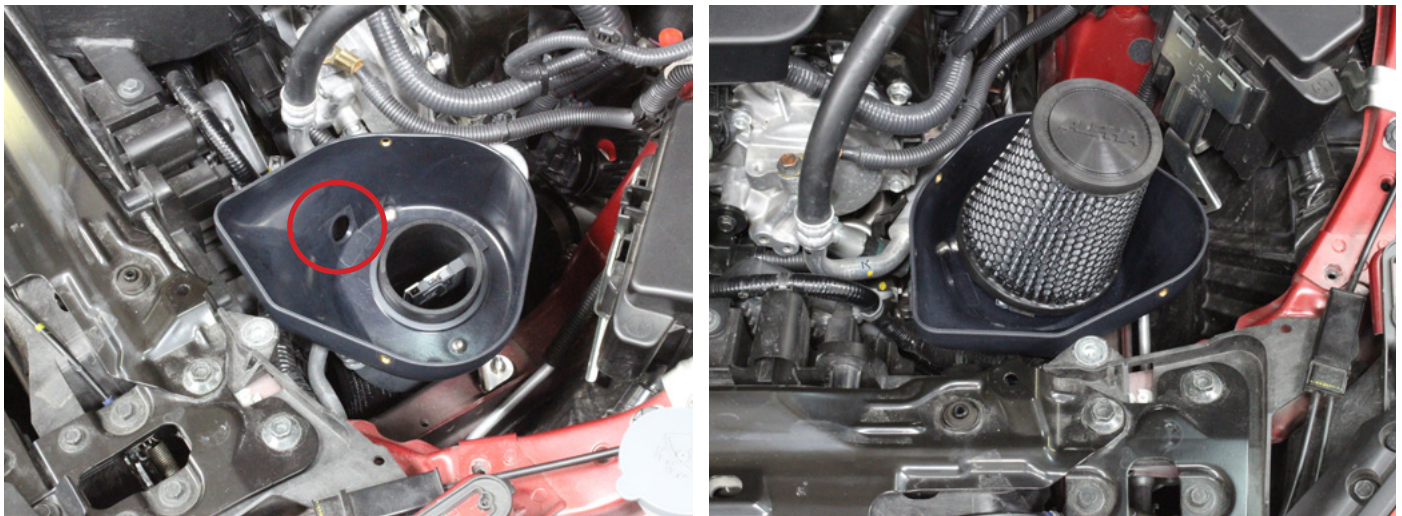

30. Locate the upper air box lid and two of the short stainless steel M6 button head bolts. Remove the rubber mounting grommets from the OEM air box. Do so by removing the metal sleeve in the grommet first then the grommet itself. Reinstall the grommets into the Alpha upper air box in the reverse order, grommet first then the metal sleeve second. Install the upper lid and install the two shorter M6 bolts making sure to not over tighten them. Lastly, reinstall the OEM M6 mounting bolts and center the bolt within the grommet.

**NOTES:** Over tightening the short M6 bolts that hold together the upper and lower sections of the air box can lead to insert damage, seized bolts, or pulling the insert out completely.

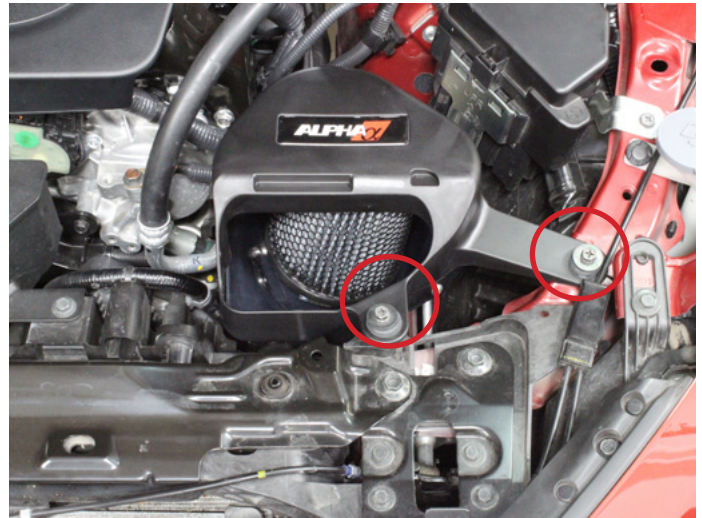
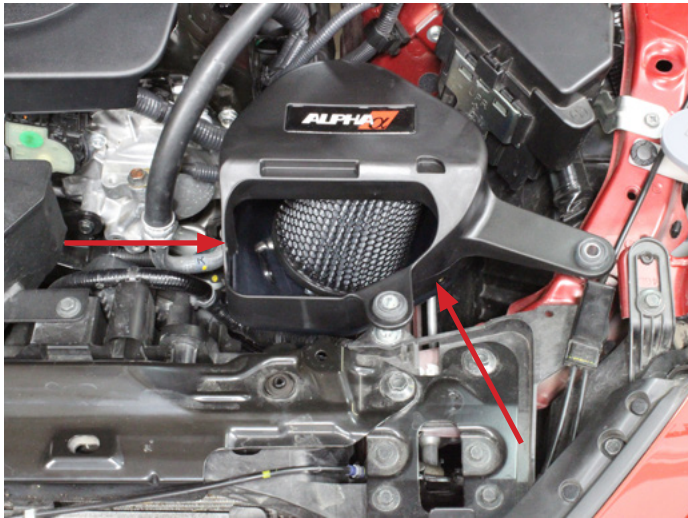

## Adjustment and Panel Reinstallation

31. Once both air boxes are installed, test fit the OEM air box inlet duct / core support cover. If the air boxes are installed correctly, the panel will line up and seal correctly. If any side to side adjustments need to be made to align the duct, loosen the M6 air box mounting bolts and adjust as needed. It is also possible that you may need to adjust the silicone on the turbo inlet if it was not installed correctly. Misalignment of the silicone may cause the air box to look twisted and the tops of the air boxes may not look flat. Adjust as needed or until you have a satisfactory installed fitment and appearance.

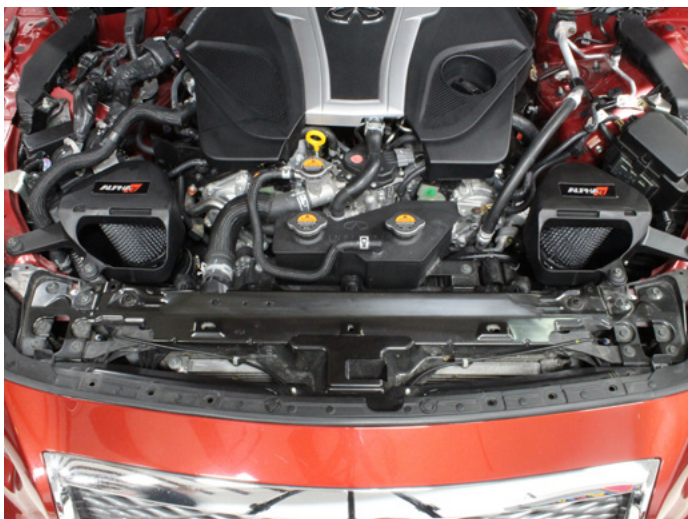

32. Reinstall the remaining engine bay trim panels that were removed in the first few steps, in the reverse order of uninstallation.

Enjoy!!

## Alpha Filter Cleaning

---

Alpha/AMS filters feature a specially designed media that allows performance and efficiency to be restored to near new each time by simply using compressed air from inside out, making frequent washing unnecessary in order to restore filter performance.

Alpha/AMS filters feature a media that is fully compatible with washing.

Biodegradable cleaners such as Simple Green or other mild shop degreasers can be used. Simply place the filter in a solution or spray the cleaner on the filter. Allow the solution to loosen the particulate and then rinse thoroughly. Shake the filter or use compressed air from the inside outward to remove residual water and allow a full day or two to dry. While the media may discolor, filter efficiency and restriction are not affected.

**Note: Always follow the dilution and application time instructions for “light cleaning” as indicated by the cleaner manufacturer**