



370Z REAR TRACTION ARM INSTALLATION INSTRUCTIONS:

**09-15 NISSAN 370Z/FAIRLADY Z Z34
07-08 INFINITI G35 SEDAN/SKYLINE SEDAN V35
08-13 INFINITI/NISSAN G37/SKYLINE V36**

**PART NUMBER:
TRNS-0400**

We recommend that installation of all Voodoo13 parts be completed by a professional who is experienced in suspension tuning. With proper installation and maintenance, Voodoo13 suspension products will provide exceptional performance and durability. For any questions, please contact Voodoo13 immediately. We thank you for choosing Voodoo13 for your suspension tuning needs!

NEED HELP?

Our representatives are here to help you with any questions concerning the operation of this product.

CALL 480-889-0812

Monday thru Friday 8:30am to 5:30pm MST

RECOMMENDED TOOLS AND SUPPLIES

- General Mechanics Tool Set

PART BREAKDOWN

NOTE: For any OE hardware please refer to OEM service manual for torque specifications. For all included hardware please torque to specifications shown below.

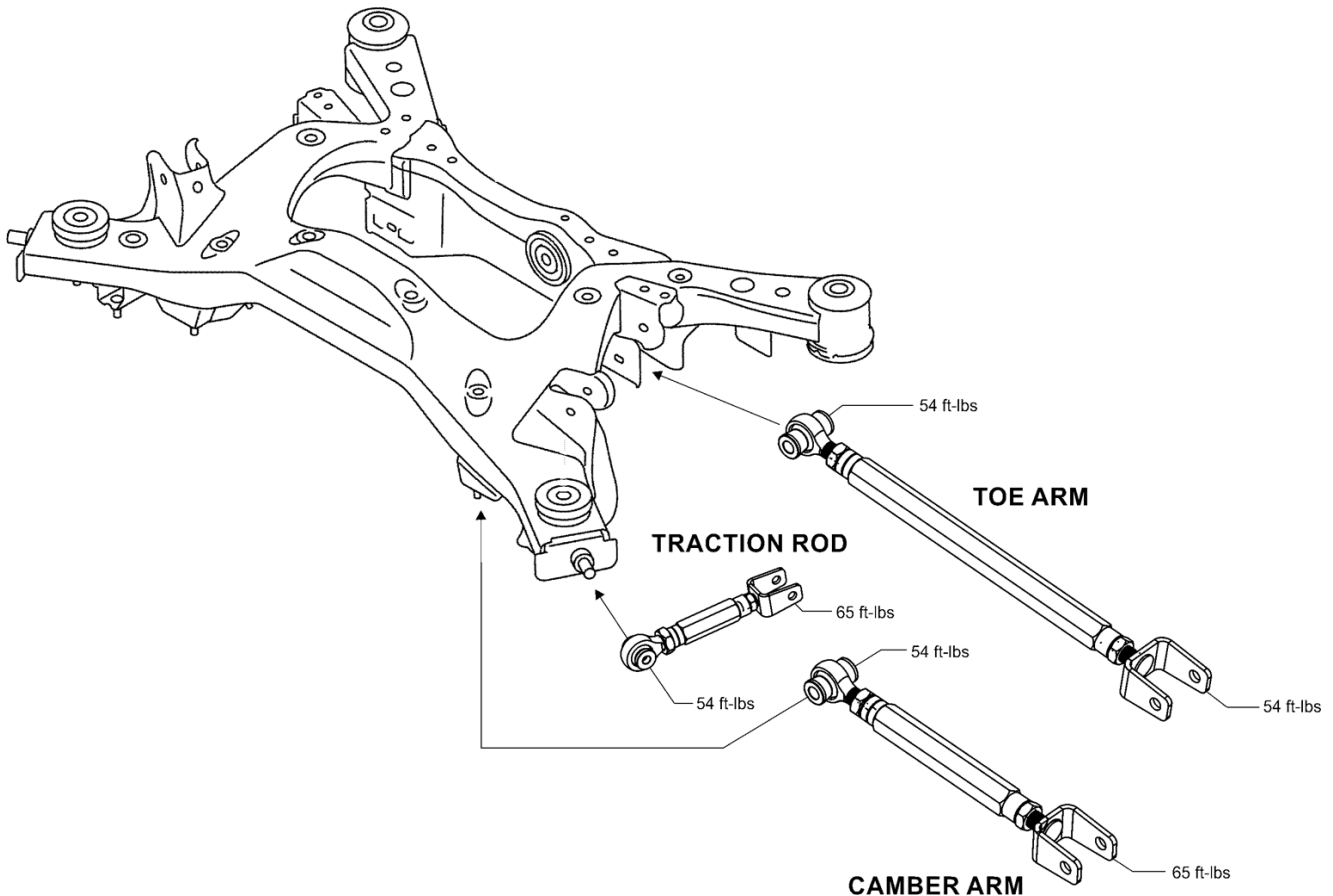

INSTALLATION PROCEDURE

Step 1: Lift the vehicle to a safe height using the recommended factory lift points to work underneath the rear suspension. Ensure to place safety jack stands where recommended by Nissan before anyone goes underneath the car (unless using a vehicle lift with safety locks).

Step 2: Remove the rear wheels from the vehicle to gain access to the hardware securing the traction arm to the vehicle.

Step 3: First locate the rear camber arm. Remove the bolt on the knuckle side in order to give the knuckle enough range of motion to remove the traction rod.

Step 4: Next remove the bolt securing the bracket end of the traction arm. The bracket end is attached to the rear knuckle of the car.

Step 5: To remove the arm, remove the bolt threaded into the subframe. Then move the rear knuckle out of the way for the stock traction rod bracket to clear and slide out.

Step 6: Place both the OEM and the new arm side by side for length reference. Set the arm to the OEM length first. NOTE: Lowered vehicles should shorten the arm to decrease the bumpsteer curve, however start with the OEM length as a baseline.

Step 7: Installation of the new arm begins by installing the bracket end on to the rear knuckle first. Do not install the bolt on the bracket end yet as it will increase the difficulty of the installation.

Step 8: Next install the spherical end of the traction arm and slip the larger spacer onto dowel pin located on the subframe. NOTE: Larger spacer has a tapered hole like OEM for a self-locating fit.

Step 9: Next, place the spacer washer on the outside of the spherical end and install bolt into the dowel pin. **TORQUE** bolt to **54ft-lbs**.

Step 10: Last step is to bolt up the bracket end to the knuckle of both the traction and camber arm and **TORQUE** to **65ft-lbs**.

Step 11: Reinstall the wheels and torque the lugnuts to factory specifications via factory service manual.

Step 12: Lower vehicle safely back to the ground and perform a vehicle alignment. You are finished!

ROD END ADJUSTMENT GUIDELINES

When adjusting rod end to desired position, adjust so that the rod end and adjuster have approximately the same amount of thread showing. Always use the jam nuts to secure the rod end and adjuster. Never tighten the rod end into the adjuster or the adjuster in the lower control arm as a jamming mechanism.

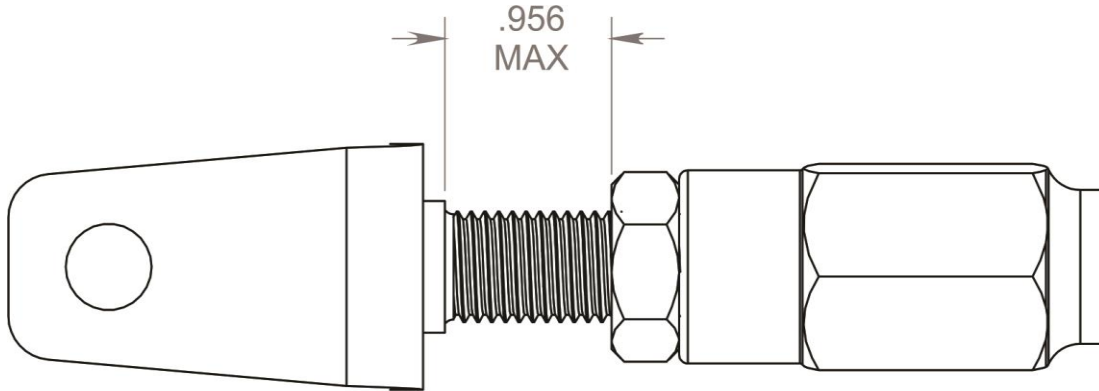

CORRECTLY ADJUSTED

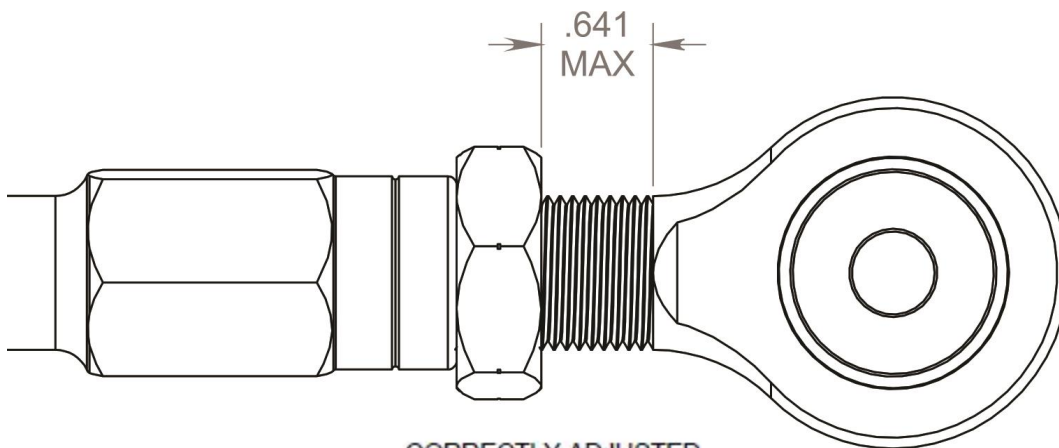

CORRECTLY ADJUSTED

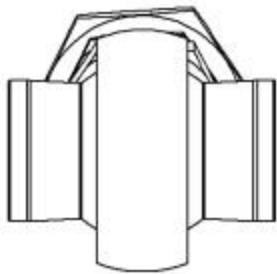

CORRECTLY POSITIONED

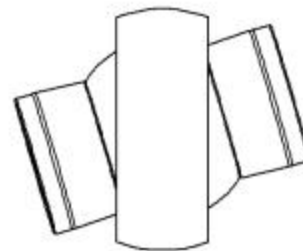

INCORRECTLY POSITIONED
TOO MUCH STATIC ROD END MISALIGNMENT

WARRANTY

All products sold are subject to the following warranty:

Voodoo13 offers a Limited Lifetime Warranty for our products to the original retail consumer against defects and workmanship when used on light truck and car applications under normal operating conditions. This warranty does not apply to parts that have been improperly installed or wearable items such as, but not limited to, worn bushings or bearings unless proven to be defective from the manufacturer.

Exterior finish on all Voodoo13 products is not considered a valid warranty; consumers are responsible for the maintenance of paint, anodize or raw metal finish.

The consumer will be responsible for the removal and freight costs both to and from the Distributor from which the product was originally purchased. Proof of purchase and product registration through the Voodoo13 website is mandatory in order to receive warrantee replacement; original invoice from the Distributor from which the product was purchased must accompany the product in question for warrantee.

Voodoo13 has the right to refuse a warrantee claim if procedures are not met by the original consumer. All returns must have an R.M.A. approval from Voodoo13 prior to shipping direct to the Voodoo13 facility. Exclusions from this warranty are sales outside of the United States, the finish, dents, rust, or any condition caused by abnormal use or neglect.

WARNING

High performance parts. For off-road use only. Installation should be carried out by a qualified facility. Improper use or installation may result in injury or death.



VOODOO13
254 W Broadway Rd
Mesa, AZ 85210
Ph: 480.889.0812
Fax: 480.829.8103
www.VOODOO13USA.com