

Load**LIFTER**7500**XL**



Installation Guide

Kit 57596

Ford Super Duty



Representative vehicle image

MN-1033 • (021703) • ECR 8766

For maximum effectiveness and safety, please read these instructions completely before proceeding with installation.

Failure to read these instructions can result in an incorrect installation.

Load**LIFTER**7500

Table of Contents

A. Installation Diagrams	2
B. Hardware and Tools Lists	3
Hardware List	3
Tools List	3
C. Introduction	4
Important Safety Notice	4
Notation Explanation	4
D. Installing the LoadLifter 7500 XL System	5
Getting Started	5
Installing the Braces	6
Retaining Clip L-Bracket Installation on Brace	7
Driver's Side Brace Installation	8
Passenger's Side Brace Installation	10
Air Spring and Bracket Assembly	11
Attaching the Assemblies to the Frame	16
Attaching the Lower Bracket to the Axle	19
E. Installing the Air Lines	23
Tips for Installing Air Lines	24
Installing the Heat Shield	24
F. Finished Installation Photos	25
G. Before Operating	26
Checking for Leaks	26
Fixing Leaks	26
Installation Checklist	27
Post-Installation Checklist	27
H. Product Use, Maintenance and Servicing	28
Minimum and Maximum Pressure	28
Maintenance Guidelines	28
Tuning the Air Pressure	29
Guidelines for Adding Air	29
I. Troubleshooting Guide	30
Frequently Asked Questions	30
Limited Warranty and Return Policy	33
Replacement Part Information	33
Contact Information	33



A. Installation Diagrams

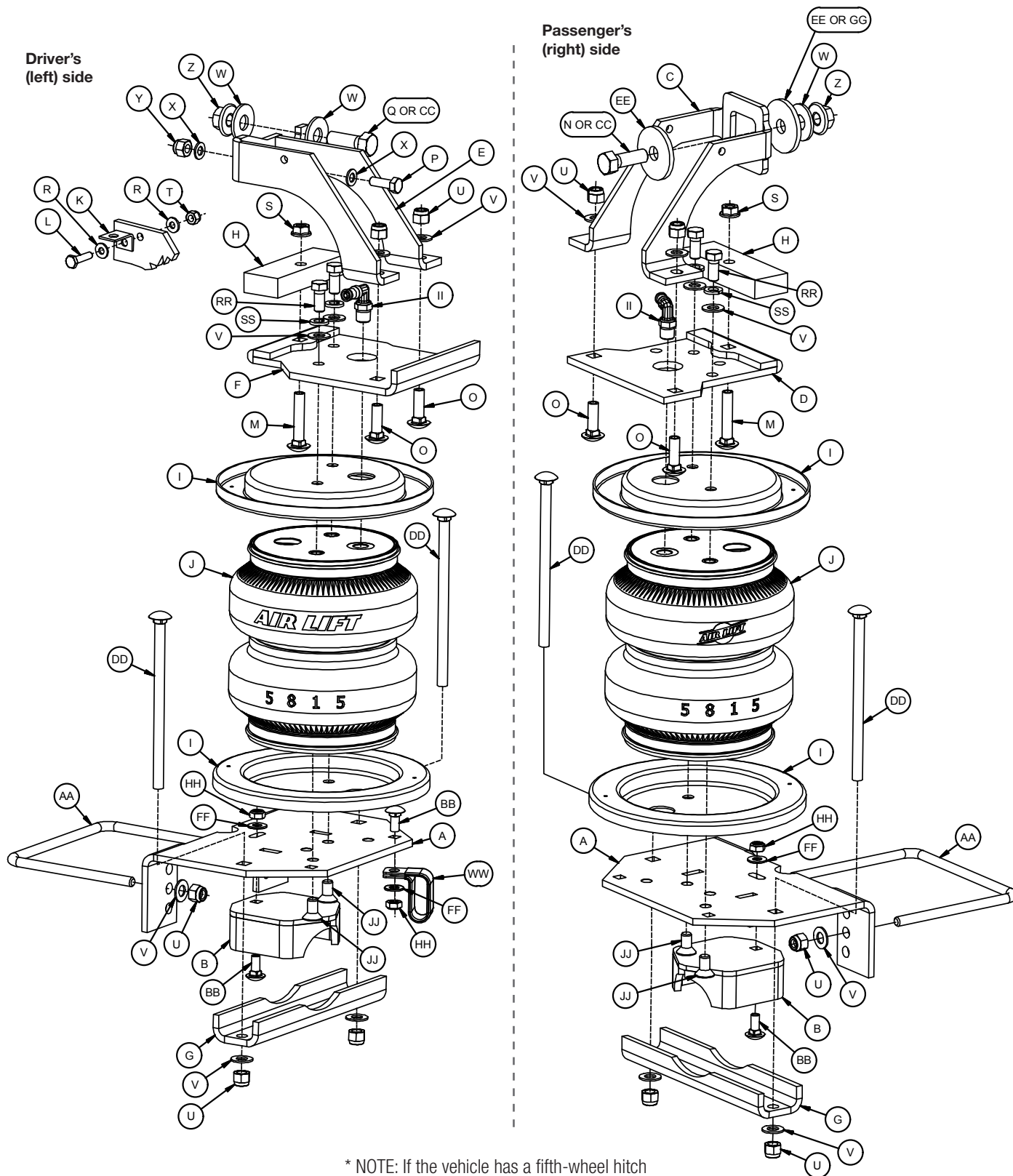

* NOTE: If the vehicle has a fifth-wheel hitch installed that has side plates along the frame, use the existing hardware that was removed. If not, use the 1/2" hardware supplied and recommended in this kit and in the directions in this manual.

fig. A.1

B. Hardware and Tools Lists

HARDWARE LIST

Item	Part #	Description.....	QTY	Item	Part #	Description.....	QTY
A	03964	Lower bracket main plate	2	AA	11717	U-bolt.....	2
B	03998	Lower bracket cup.....	2	BB	17113	5/16"-18 x 1" Carriage bolt	3
C	07975	Upper brace, RH.....	1	CC	17271	1/2"-13 x 3" Hex cap screw	2
D	07965	Upper bracket, RH.....	1	DD	17387	3/8"-16 x 10" Carriage bolt	4
E	07676	Upper brace, LH.....	1	EE	18207	1/2" Thick flat washer.....	2
F	07666	Upper bracket, LH.....	1	FF	18433	5/16" Flat washer.....	7
G	01851	Clamp bar	2	GG	18556	3/4" Flat washer.....	1
H	13966	Spacer	2	HH	18613	5/16"-18 Thin nylon lock nut	2
I	11897	Roll plate.....	4	II	21830	90° Swivel elbow fitting	2
J	58115	Air spring	2	JJ	17215	3/8"-24 x 3/4" Flat-head screw	4
K	10886	L-bracket	1	KK	20086*	Air line	1
L	17135	1/4"-20 x 1" Hex cap screw	1	LL	10466*	Zip tie.....	6
M	17140	3/8"-16 x 2" Carriage bolt	2	MM	21230*	Valve cap	2
N	17161	1/2"-13 x 1.5" Hex cap screw	1	NN	18501*	5/16" Flat washer.....	2
O	17361	3/8"-16 x 1.25" Carriage bolt	4	OO	21234*	Rubber washer	2
P	17177	M8-1.25 x 25mm Hex cap screw	1	PP	18411*	Star washer.....	2
Q	17412	1/2"-13 x 1.25" Hex cap screw	1	QQ	21233*	5/16" Hex nut.....	4
R	18419	#12 Flat washer	2	RR	17203	3/8"-24 x 7/8" Hex cap screw	4
S	18422	3/8"-16 Serrated flange lock nut	2	SS	18427	3/8" Lock washer.....	4
T	18425	1/4"-20 Nylon lock nut.....	1	TT	17103*	5/16"-18 x 1" Hex cap screw	2
U	18435	3/8"-16 Nylon lock nut.....	12	UU	18438*	5/16"-18 Nylon lock nut.....	3
V	18444	3/8" Flat washer.....	16	VV	22640*	High-temp zip tie	1
W	18485	1/2" Flat washer.....	3	WW	26333	Modified P-clamp	1
X	18501	M8 Flat washer	2	XX	11901*	Emergency brake cable secondary bracket	1
Y	18522	M8-1.25 Nylon lock nut	1	YY	11908*	Emergency brake cable primary bracket	1
Z	18505	1/2"-13 Serrated flange lock nut	2				

* Not shown in the Install Diagram

TOOLS LIST

Description.....	Qty
Metric & standard open-end box wrenches.....	set
Ratchet with metric & standard sockets	set
Standard hex keys.....	set
Drill and 5/16" drill bit.....	1
Torque wrench.....	1
Hose cutter, razor blade or sharp knife	1
Hoist or floor jack	1
Safety stands.....	2
Safety glasses	1
Air compressor or compressed air source	1
Spray bottle with dish soap/water solution.....	1



Missing or damaged parts? Call Air Lift customer service at (800) 248-0892 for a replacement part.

C. Introduction

The purpose of this publication is to assist with the installation, maintenance and troubleshooting of the LoadLifter 7500 XL air spring kit. LoadLifter 7500 XL utilizes sturdy, reinforced, commercial grade single or double, depending on the kit, convolute bellows. The bellows are manufactured like a tire with layers of rubber and cords that control growth. LoadLifter 7500 XL kits are recommended for most 3/4- and 1-ton pickups and SUVs with leaf springs and provide up to 7,500 pounds of load leveling support with air adjustability from 5-100 PSI.

It is important to read and understand the entire installation guide before beginning installation or performing any maintenance, service or repair. The information here includes a hardware list, tool list, step-by-step installation information, maintenance guidelines and operating tips.

Air Lift Company reserves the right to make changes and improvements to its products and publications at any time. For the latest version of this manual, contact Air Lift Company at **(800) 248-0892** or visit **airliftcompany.com**.

IMPORTANT SAFETY NOTICE

The installation of this kit does not alter the gross vehicle weight rating (GVWR) or payload of the vehicle. Check your vehicle’s owner’s manual and do not exceed the maximum load listed for your vehicle.

Gross vehicle weight rating: The maximum allowable weight of the fully loaded vehicle (including passengers and cargo). This number — along with other weight limits, as well as tire, rim size and inflation pressure data — is shown on the vehicle’s Safety Compliance Certification Label.

Payload: The combined, maximum allowable weight of cargo and passengers that the truck is designed to carry. Payload is GVWR minus the base curb weight.

NOTATION EXPLANATION

Hazard notations appear in various locations in this publication. Information which is highlighted by one of these notations must be observed to help minimize risk of personal injury or possible improper installation which may render the vehicle unsafe. Notes are used to help emphasize areas of procedural importance and provide helpful suggestions. The following definitions explain the use of these notations as they appear throughout this guide.



INDICATES IMMEDIATE HAZARDS WHICH WILL RESULT IN SEVERE PERSONAL INJURY OR DEATH.



INDICATES HAZARDS OR UNSAFE PRACTICES WHICH COULD RESULT IN SEVERE PERSONAL INJURY OR DEATH.



INDICATES HAZARDS OR UNSAFE PRACTICES WHICH COULD RESULT IN DAMAGE TO THE MACHINE OR MINOR PERSONAL INJURY.

NOTE

Indicates a procedure, practice or hint which is important to highlight.

D. Installing the LoadLifter 7500 XL System

GETTING STARTED

1. Raise the vehicle and support it in a way, using jack stands or equivalent, that the axle can be safely dropped away from the frame. This will need to be done in order for the air spring assembly to be put into position between the axle and frame (Fig. D.1).

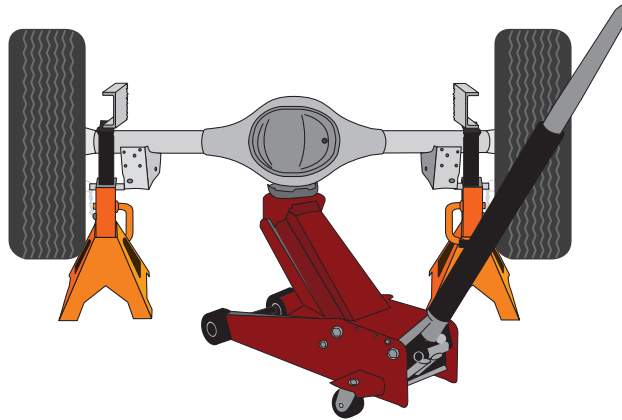

fig. D.1

2. Remove the jounce bumpers from under the frame, over the axle (Figs. D.2 & D.3).

NOTE

Use a wire brush and some penetrating oil on the jounce bumper to help in its removal. The socket size for the nut is typically 15mm.

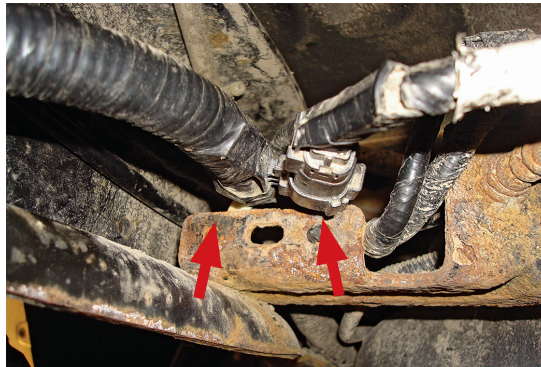

fig. D.2



fig. D.3

3. If necessary, disconnect the wiring harness from the driver's side frame rail to gain clearance for the upper brace (Fig. D.4). Also, push out the harness connector that holds the electrical lines going to the gas/urea tank in or out of the tank bracket. This will improve socket/bolt access that will be required for installing and tightening the frame brace (Fig. D.5).



Remove the line holders from the gas/urea tank bracket for easier access to the upper brace hardware.

fig. D.4

4. If the truck has a fifth-wheel hitch already installed, **other than the standard factory Reese** hitch purchased with the truck, it will be necessary to remove the hardware that bolts the side bracket (plates) to the outside of the frame above the axle.

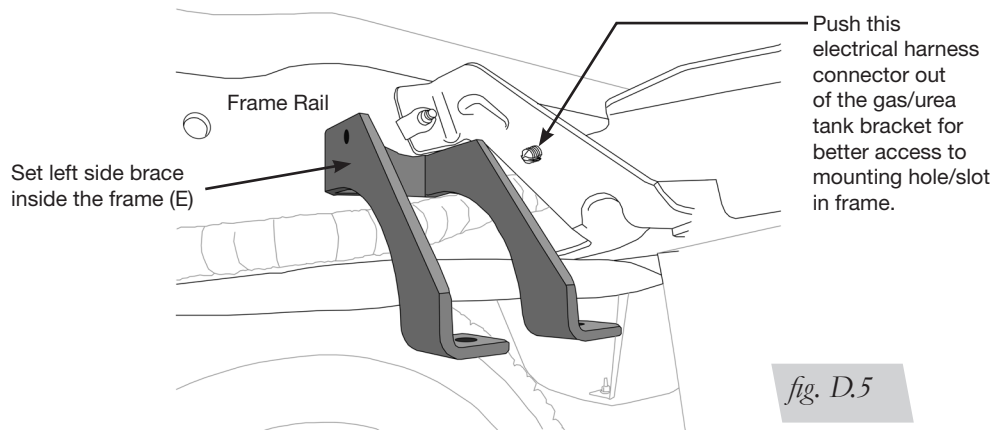
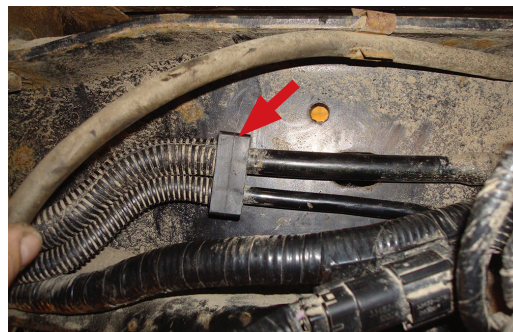

fig. D.5

INSTALLING THE BRACES

Gas engine models have emission lines on the inside of the frame. If the truck has emission lines running along the inside of the frame rail (Fig. D.6), it will be necessary to relocate those lines as follows:

1. Carefully push the line holder out of the frame above the axle. Try to minimize damage because it will be reused later. It may also be helpful to remove any emissions/fuel line retaining clips forward or rearward of the axle to aid in positioning the lines once the upper brace has been installed (Figs. D.6 & D.7). The same holds true for the electrical wire loom retaining clips.



If equipped, this emissions/fuel line retaining clip must be pulled away from the frame in order to install the upper frame brace (E).

fig. D.6

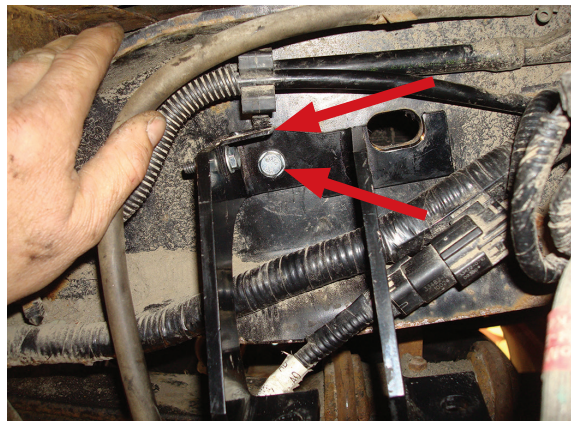

Image shows lines clear on the frame, opening it up for the brace installation.

fig. D.7

RETAINING CLIP L-BRACKET INSTALLATION ON BRACE

1. In order to reattach the previously removed emissions line, attach the provided L-bracket (K) to the back frame brace using the 1/4"-20 x 1" bolt (L), flat washers (R) and 1/4"-20 nylon lock nut (T) supplied (Fig. D.5). Placing this L-bracket depends on where the line holder is on the wiring or the emissions line that was previously pulled from the frame. Set the driver's side frame brace (E) against the frame and insert the 8mm-1.25 x 25mm hex cap screw (P) with an M8 flat washer (X) through the brace and into the hole in the side of the frame from which the line holder was removed (Fig. D.8). This will hold the line in place. Note which side the line holder is in, in respect to the back leg of the brace. Is it forward or behind the back leg of the brace? Where the line holder lines up is the side where the L-bracket is to be installed (Figs. D.5 & D.8).



Brace being temporarily held in place by the M8 bolt and washer. L-bracket is shown in location already. Note: The side the line holder is on depends on the location of the factory retaining clip.

fig. D.8

2. Pull the brace back out and attach the L-bracket onto the brace with the hardware noted above, in the proper location previously found (Figs. D.9 & D.10). Make sure the L-bracket faces up and tighten securely.

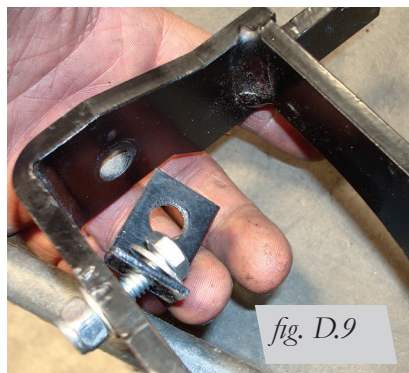

fig. D.9

Attach the L-bracket to the brace in the position previously found using the hardware specified.

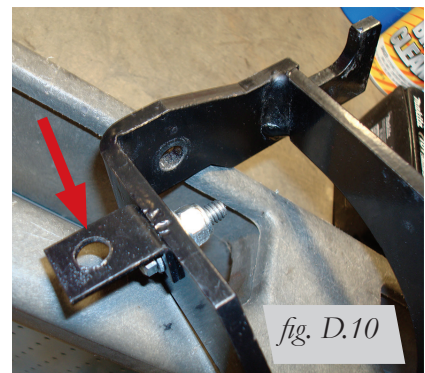

fig. D.10

No matter what side the L-bracket is on, make sure it is installed so the flat side points up when tightening.

DRIVER'S SIDE BRACE INSTALLATION

1. Set the left upper brace (E) into the driver's side frame rail. The brace has a small hole that will line up with an existing hole in the frame. Insert the M8-1.25 x 25mm hex cap screw (P) with an M8 flat washer (X) through the brace and frame (Figs. D.11 & D.12) and cap with a M8 flat washer (X) and M8-1.25 nylon lock nut (Y). Leave loose at this time.

CAUTION

BE SURE NOT TO PINCH THE PREVIOUSLY MOVED WIRING OR LINES INSIDE THE LEFT FRAME RAIL.

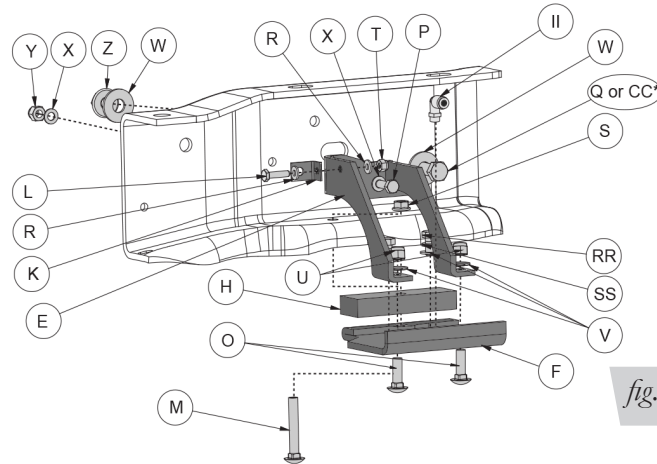
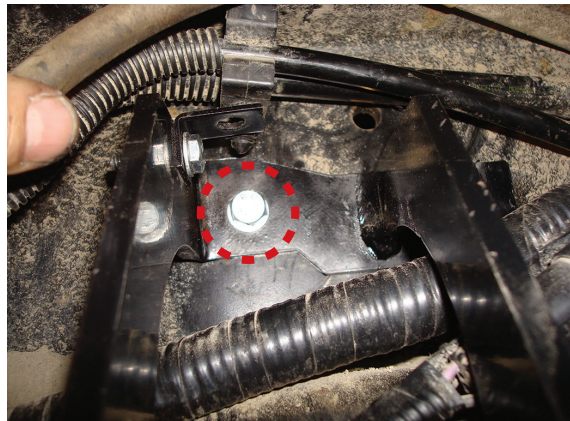

fig. D.11



Attach the bracket to the frame using the 8mm hardware noted.

fig. D.12

2. If the truck has no fifth-wheel hitch or if it has the **standard equipment Reese fifth-wheel hitch** that was purchased on the truck from Ford, in the frame there is a slot that is forward of the 8mm bolt just installed, insert the 1/2"-13 x 1.25" hex cap screw (Q) and 1/2" flat washer (W) through the brace and frame (from the inside out). Cap with a 1/2" flat washer (W) and a 1/2"-13 serrated flange lock nut (Z) (Figs. D.11, D.13 & D.14). Do not tighten at this time.

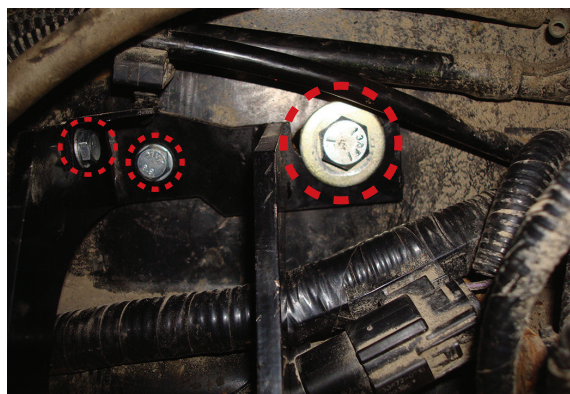

Driver's side brace shown with supplied hardware in place. Existing fifth-wheel hardware which may have been removed may look different.

fig. D.13

If the truck has an aftermarket fifth-wheel hitch that has an outer bracket (plate) running along side of the frame and it used this slot to secure the bracket with existing hardware, install the original fifth-wheel hardware previously removed in the “getting started section” from the fifth-wheel installation for securing the brace (Fig. D.11). Do not tighten at this time.

OR

If the truck has an aftermarket fifth-wheel hitch that has an outer bracket (plate) running along side of the frame and it **does not have** any attaching hardware on the side where the slot in the frame is, it will be necessary to drill a 1/2” hole through the plate using the slot in the frame as a template. Drill the hole as far to the rear of the slot as possible.

CAUTION

CLEAR ANY ELECTRICAL OR HARD LINES FROM THE AREA SO AS NOT TO DAMAGE THEM IN ANY WAY WHEN DRILLING THE HOLE.

NOTE

It may be necessary to mark and remove the outer bracket (plate) from the side of the frame in order to drill the hole correctly. Reattach once the hole is drilled.

3. Insert a 1/2”-13 x 3” hex cap screw (CC) with a 1/2” flat washer (W) through the brace, frame and fifth-wheel plate previously drilled. Cap with a 1/2” flat washer (W) and a 1/2”-13 serrated flange lock nut (Z) (Fig. D.14). Leave loose at this time.

Rear view of driver’s (left) side shown

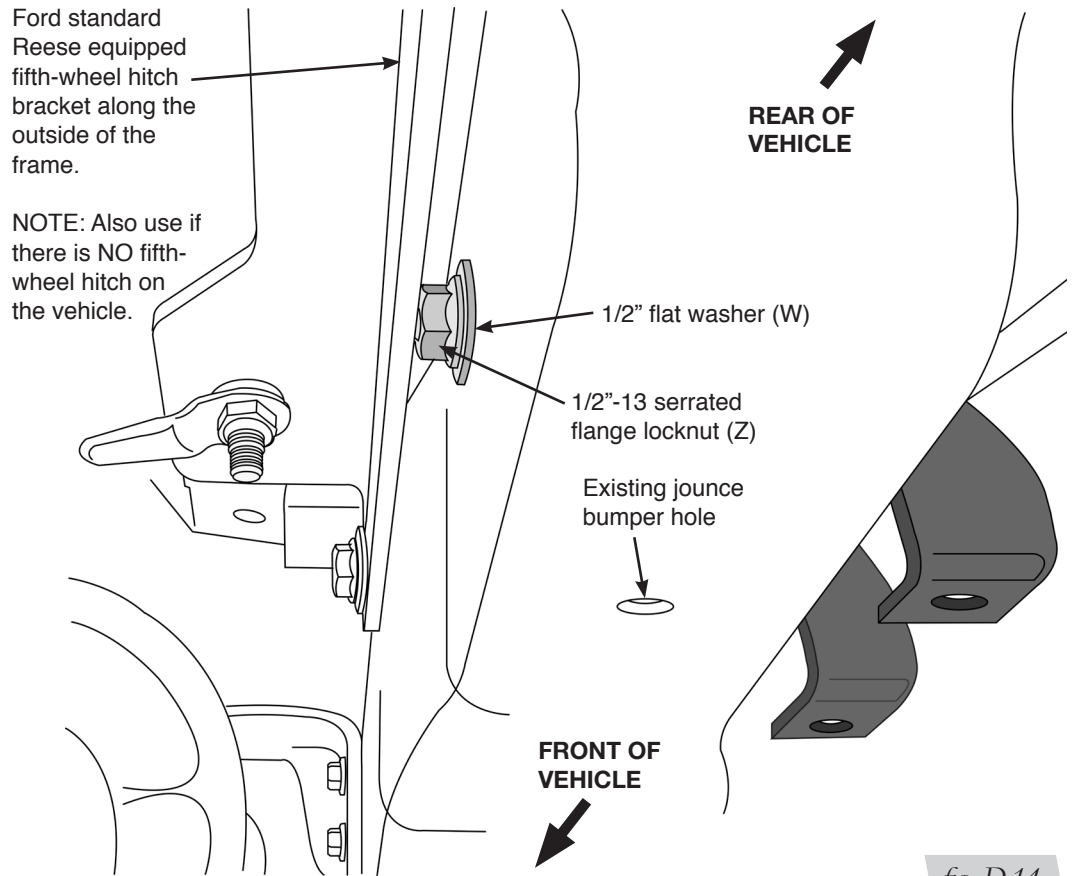
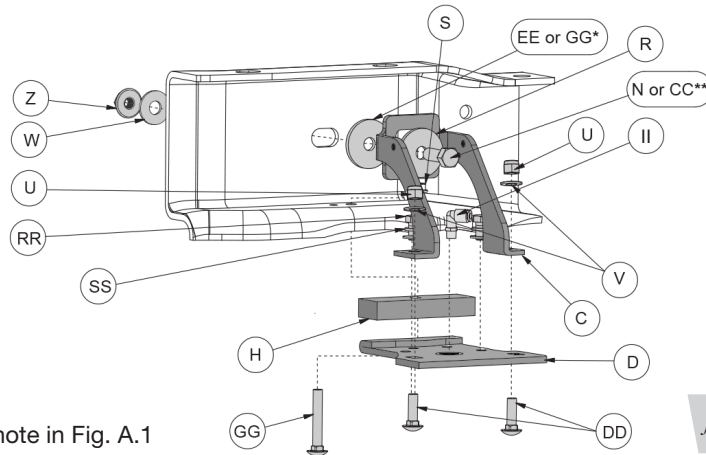

fig. D.14

PASSENGER'S SIDE BRACE INSTALLATION

1. Set the right upper brace (C) into the passenger's side frame rail (Figs. D.15, D.16 & D.17).

Inside view of passenger's (right) side frame shown



* & ** See footnote in Fig. A.1



For the passenger's side, before inserting the upper brace hardware, make sure that the 1/2" thick flat washer (EE) or (GG) is installed in between the brace and frame (see Step 2). Note: The 1/2" thick flat washer (EE) is not a half inch thick. It has a 1/2" hole and is a thick washer.

fig. D.16



Passenger's side upper brace shown with hardware supplied in place.

fig. D.17

- For trucks with no fifth-wheel or the OEM purchased Reese fifth-wheel hitch, insert the 1/2"-13 x 1.5" hex cap screw (N) and 1/2" thick flat washer (EE) through the brace, between the brace and the frame add the 1/2" thick flat washer (EE) then through the frame (from the inside out). **Note:** The 1/2" thick flat washer (EE) is not a half inch thick. It has a 1/2" hole and is a thick washer. Cap with a 1/2" flat washer (W) and a 1/2"-13 serrated flange lock nut (Z) (Figs. D.14 & D.15). Do not tighten at this time.

OR

If the truck has an aftermarket fifth-wheel hitch that has an outer bracket (plate) running along side of the frame and it used this slot to secure the bracket to the frame with existing hardware, re-install the original hardware previously removed in the "Getting Started" section. However, add the 1/2" thick flat washer (EE) or 3/4" flat washer (GG) depending on whether the existing hardware is in between the brace and the frame (Fig. D.15).

NOTE

The 1/2" thick flat washer (EE) is not a half inch thick. It has a 1/2" hole and is a thick washer. Do not tighten at this time.

OR

If the truck has an aftermarket fifth-wheel hitch that has a bracket (plate) running along side of the frame and it **does not have** any attaching hardware on the side where the slot in the frame is, it will be necessary to drill a 1/2" hole through the plate using the slot in the frame as a template.

NOTE

It may be necessary to mark and remove the bracket (plate) from the side of the frame in order to drill the hole correctly. Reattach once the hole is drilled.

Insert a 1/2"-13 x 3" hex cap screw (CC) with a 1/2" thick flat washer (EE) through the brace, between the brace and the frame add the 1/2" thick flat washer (EE) then through the frame and fifth-wheel plate previously drilled. **NOTE:** The 1/2" thick flat washer (EE) is not a half inch thick. It has a 1/2" hole and is a thick washer. Cap with a 1/2" flat washer (W) and a 1/2"-13 serrated flange lock nut (Z) (Fig. D.14). Leave loose at this time.

AIR SPRING AND BRACKET ASSEMBLY

- Set roll plates (I) over the top and bottom of the air springs (J) (Figs. A.1 & D.18).

NOTE

The radiused (rounded) edge of the roll plate (I) will be toward the air spring so that the air spring is seated inside both roll plates.

- Install the swivel elbow fitting (II) into the top of the air spring finger tight. Tighten the swivel fitting one and a half turns.

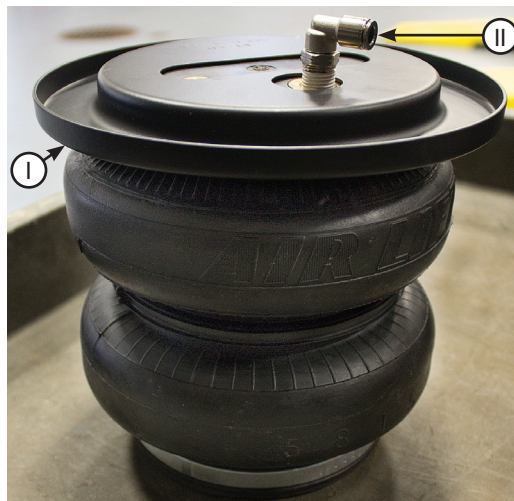

Set roll plate (I) over the air spring and install the fitting (II) as stated. Repeat for both air spring.

fig. D.18

3. Insert a 5/16"-18 x 1" carriage bolt (BB) through the square hole in the lower bracket cup (B). Make sure to insert the carriage bolt on the flanged side of the bracket. Set the assembly onto the lower bracket main plate (A) making sure the lower bracket cup (B) is on the flanged side of the bracket (Fig. D.19).

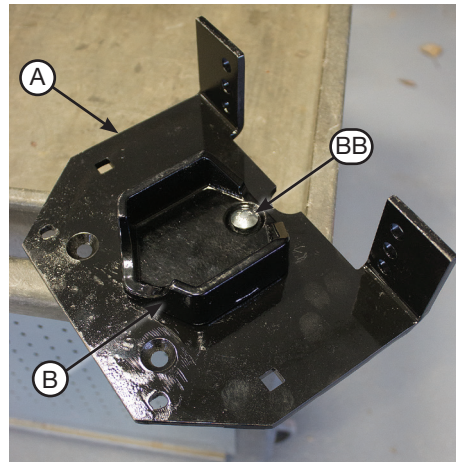
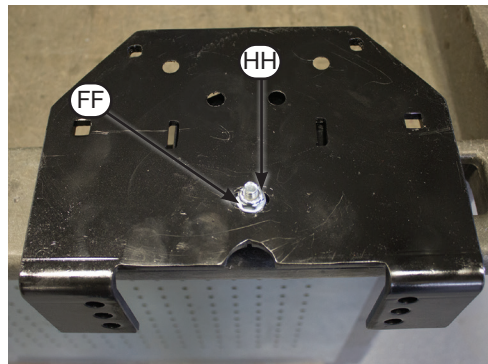

fig. D.19

4. Flip the assembly over and cap the 5/16"-18 x 1" carriage bolt with a 5/16" flat washer (FF) and 5/16" thin nylon lock nut (HH) (Fig. D.20). Tighten the nut only tight enough so that the cup still swivels on the lower bracket main plate (Fig. D.21).



Top of lower bracket.

fig. D.20

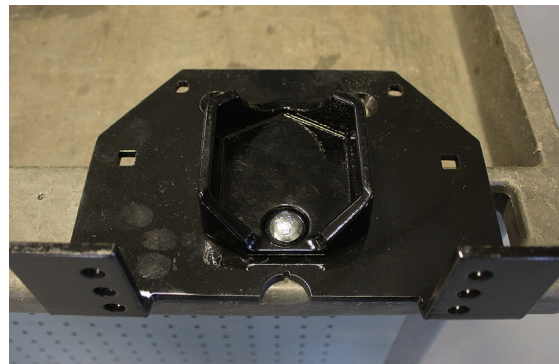

Bottom of lower bracket.

fig. D.21

5. Insert one of the 3/8"-16 x 10" carriage bolts (DD) into the lower bracket assembly previously assembled (Fig. D.22). Determine which holes correspond with either side (Fig. D.23).

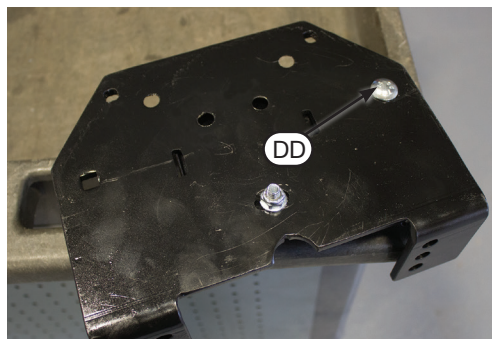

fig. D.22

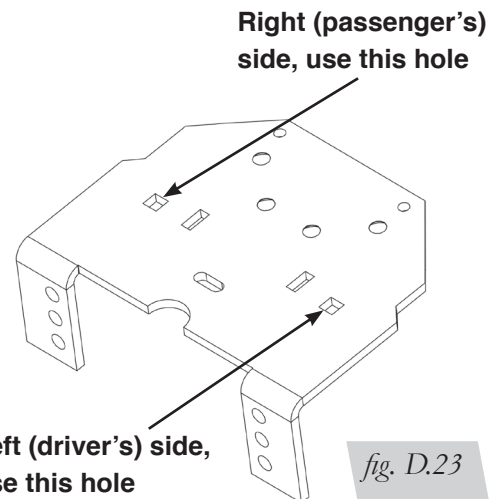
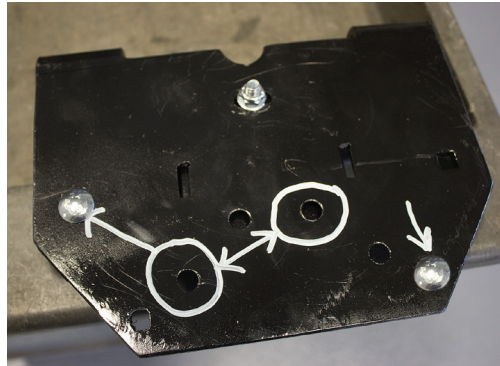

fig. D.23

NOTE

The 3/8"-16 x 10" carriage bolts will be behind the axle once the assembly is installed on the axle.

- The lower bracket assembly has two sets of air spring mounting holes, one for the driver's side, the other for the passenger's. Insert one 5/16"-18 x 1" carriage bolt (BB) into the square hole as shown for the driver's side assembly (Fig. D.24). Using the corresponding holes in the lower bracket designated (Figs. D.24 & D.25), attach the air spring to the bracket using the 3/8"-24 x 3/4" flat-head screws (JJ) and torque to no more than 20 lb.-ft. (27Nm).



Driver's side (left) air spring mounting holes shown in relation to the 3/8"-16 x 10" carriage bolt previously installed. When installing on the air spring, make sure the bracket edge facing you is on the fitting side of the air spring.

fig. D.24

This slot should be on the opposite side of the air line fitting on the air spring once mounted.

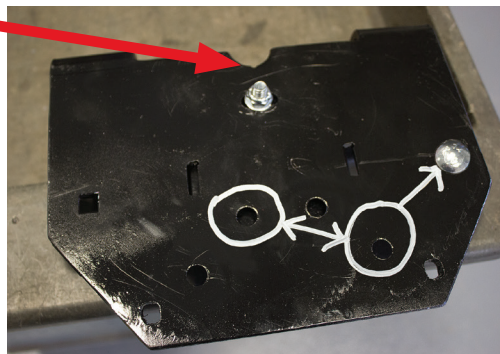

Passenger's side air spring mounting holes shown in relation to the 3/8"-16 x 10" carriage bolt previously installed. When installing on the air spring, make sure the bracket edge facing you is on the fitting side of the air spring.

fig. D.25

- Figures D.26 & D.27 shows the driver's (left) side and passenger's (right) side assemblies.

Driver's (left) side

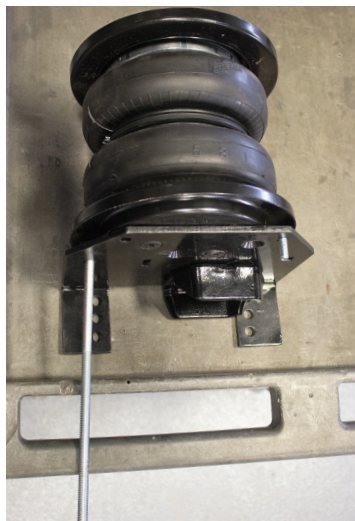
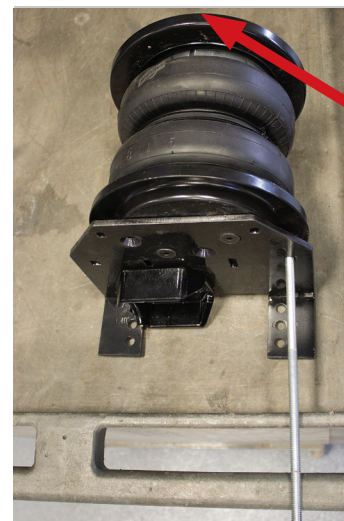

fig. D.26

Passenger's (right) side



The air fitting must be on this side of the assembly.

fig. D.27

TECH TIP

Cut a small section of cardboard and fold it in half. When assembling the upper bracket to the air spring, set this cutout under the carriage bolt between the roll plate and upper bracket to hold the carriage bolt in place. This will make it easier to tighten the mounting hardware once in place on the frame (Fig. D.28).



fig. D.28

8. Set the lower bracket assembly aside. Pick up the driver's side (F) and passenger's side (D) upper brackets (Fig. D.29). Insert two 3/8"-16 x 1.25" carriage bolts (O) up through the bottom of the driver's side (F) and passenger's side (D) upper brackets (Figs. D.29 & D.30), through the two square holes that are on the corresponding side. Also, insert one 3/8"-16 x 2" carriage bolt (M) through the remaining hole. The head of this carriage bolt will be hidden once the upper bracket is mounted to the air spring.

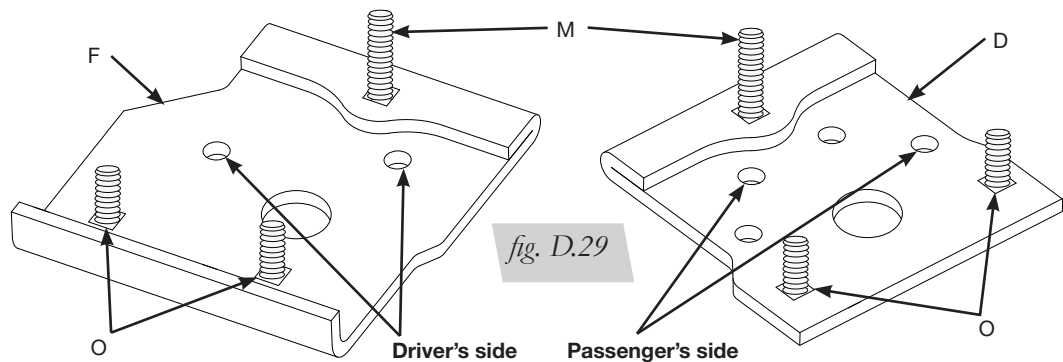

fig. D.29



fig. D.30

- Set the driver's side (left) upper bracket onto the driver's side air spring assembly previously assembled, using the holes in the upper bracket designated (Fig. D.29), and attach to the air spring with two 3/8" flat washers (V), 3/8" lock washers (SS) and 3/8"-24 x 7/8" hex cap screws (RR). Torque no more than 20 lb.-ft. (27Nm). (Figs. D.30, D.31 & D.32).

- Repeat the above process on the passenger's side assembly (Fig. D.31).

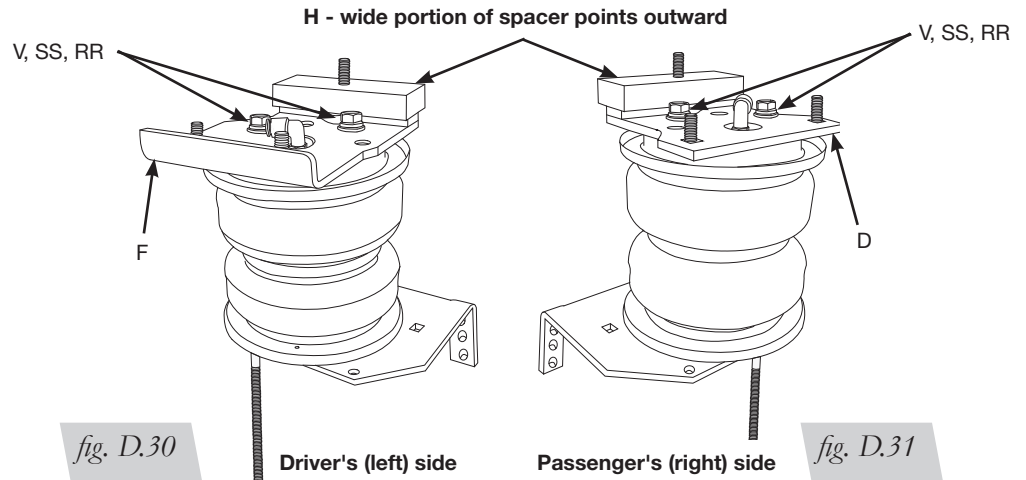

- Set the spacers (H) over both 3/8"-16 x 2" carriage bolts (M) (Figs. D.30, D.31 & D.33).

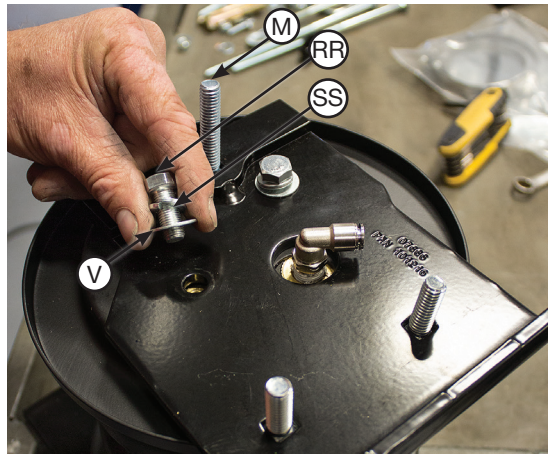

Attach the upper bracket to the air spring assembly with two 3/8" flat washers (V), 3/8" lock washers (SS), and 3/8"-24 x 7/8" hex head cap screws (RR).

fig. D.32

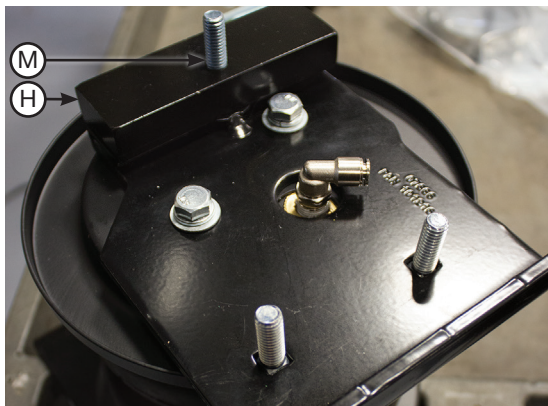

Spacer (H) set on bracket in position. The wide side of the spacer faces the outside of the vehicle.

fig. D.33

NOTE

The hole in the flat spacer (H) is offset. Install the spacer so that the wide portion faces the outside of the vehicle (Figs. D.30 & D.33).

12. Figure D.34 shows the assemblies complete and ready to install.

Driver's side assembly



Passenger's side assembly

fig. D.34

ATTACHING THE ASSEMBLIES TO THE FRAME

1. Drop the axle or raise the frame to make room to put the assemblies into position.
2. Set the driver's (left) side assembly onto the jounce bumper strike plate (Fig. D.35). Make sure the 3/8"-16 x 10" carriage bolt (DD) on the bottom bracket goes outside the hard brake line on the back side of the axle. Raise the axle just enough to insert the 3/8"-16 x 2" carriage bolt (M) (that is installed in the upper bracket) through the existing jounce bumper hole in the bottom of the frame. At the same time, line up the upper brace into the remaining two carriage bolts in the assembly's upper bracket (Fig. D.36). Do this just enough for the carriage bolts to hold the assembly into position in the frame, while resting on the jounce bumper strike plate (Fig. D.35).



The long carriage bolt must go outside the hard brake/ABS line on the driver's side.

fig. D.35

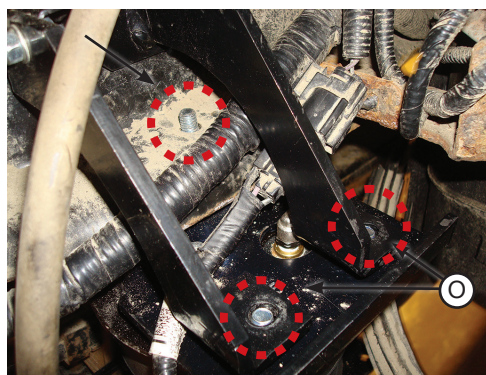

Raise the axle up while aligning the 3/8"-16 x 2" carriage bolt (M) through the frame and the two 3/8"-16 x 1.25" (O) carriage bolts in the upper bracket, through the brace.

fig. D.36

- Set the right (passenger's side) assembly into position on the jounce bumper strike plate the same way the left side was positioned (Fig. D.37). Note that the long carriage bolt goes outside of the hard brake line on the passenger's side.

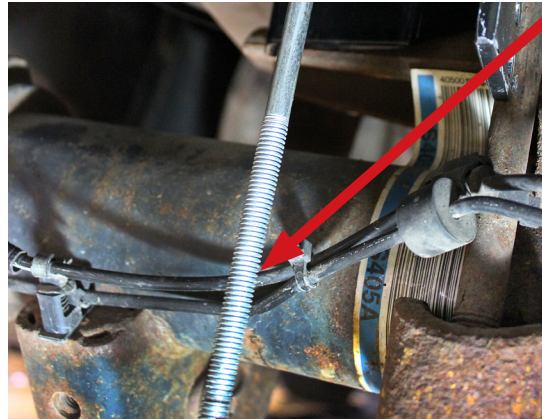

The long carriage bolt goes on the outside (backside) of the hard brake/ABS line on the passenger's side.

fig. D.37

- Make sure the thick spacer (H) is parallel to the frame and bracket (Fig. D.38). Finish raising the axle or lowering the frame until the spacer contacts the frame on both sides.

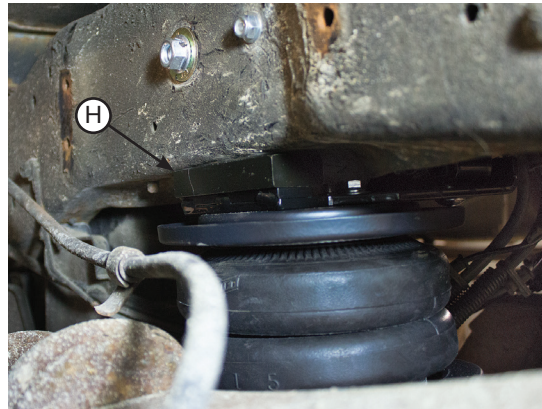

Make sure the spacer (H) is parallel to both the frame and upper bracket. Raise axle or lower frame until the spacer touches the frame on both sides.

fig. D.38

- Install the 3/8"-16 serrated flange lock nut (S) on the 3/8"-16 X 2" carriage bolt (M) that went through the existing jounce bumper hole and tighten securely on both sides (Fig. D.39).

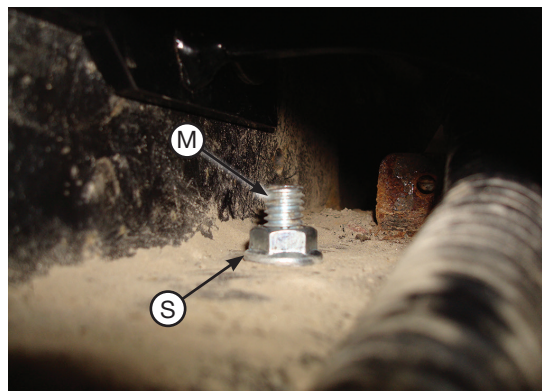

Install the 3/8"-16 serrated flange lock nut (S) onto the 3/8"-16 x 2" carriage bolt (M) that goes through the flange on the frame and tighten.

fig. D.39

CAUTION

BE SURE NOT TO PINCH THE PREVIOUSLY MOVED WIRING OR LINES INSIDE THE LEFT FRAME RAIL.

6. Cap the 3/8"-16 x 1.25" carriage bolts (O) with 3/8" flat washers (V) and 3/8"-16 nylon lock nuts (U) on both sides and torque to 15 lb.-ft. (20Nm) (Fig. D.40).

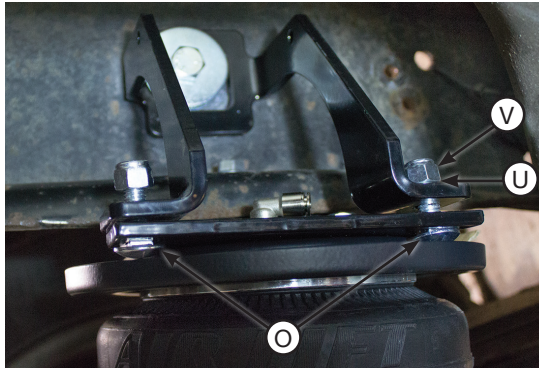

Cap the 3/8"-16 x 1.25" carriage bolts (O) with 3/8" flat washers (V) and 3/8"-16 nylon lock nuts (U), then torque to 15 lb.-ft. (20Nm). Repeat for both sides.

fig. D.40

7. With the spacers (H) on the upper brackets tight to the bottom of the frame and the braces tight to the upper brackets, tighten the 8mm (driver's side only) and 1/2" or 3/4" hardware previously installed, that hold the braces to the frame (Fig. D.41). Tighten both sides.

NOTE

If possible, use a thin socket. It helps to pull back the driver's side mounting hardware (Q or CC) as far back in the slot as possible while tightening.

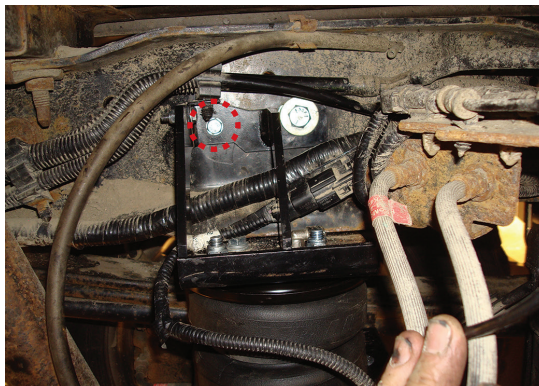

Tighten the M8 hardware and the 1/2" (or 3/4" if from the fifth-wheel hitch hardware) and tighten securely. Repeat for the hardware on the opposite side.

fig. D.41

8. Once the driver's (left) side 1/2" or 3/4" hardware has been tightened, push the wiring harness connector – which was removed in the "getting started section" – back into the gas/urea tank mounting hole. If the connector broke during disassembly, wire tie it to the bracket (Figs. D.4 & D.5).
9. If equipped with the emissions line previously loosened from the frame, insert the line holder post into the L-bracket (K) attached to the back leg of the upper left brace (E) (Fig. D.42). It may be necessary to move the line holder post forward or back on the lines to line up correctly with the L-bracket hole. Reattach any line holders removed forward or behind the axle, if possible, that were removed to aid in positioning the upper bracket.

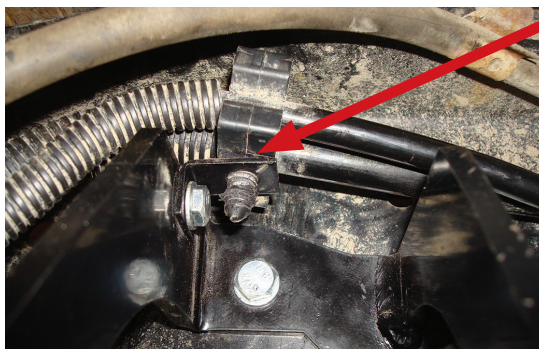

Insert the line holder previously removed into the L-bracket installed on the upper brace as shown.

fig. D.42

ATTACHING THE LOWER BRACKET TO THE AXLE

1. Push the lower bracket up against the stock U-bolts so that the legs of the lower bracket are locked into position around the stock U-bolts (Fig. D.43). It may be necessary to rotate the lower bracket on the jounce bumper strike plate in order to do this.

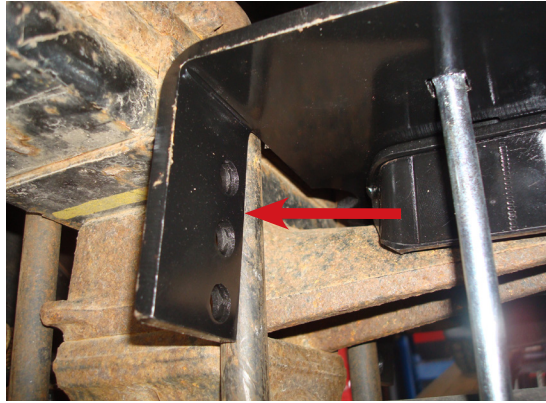

Rotate the lower bracket on the spring perch if necessary and push the bracket up against the U-bolts to put the lower bracket into position.

fig. D.43

2. Make sure the cup on the bottom of the lower bracket is nested onto the jounce bumper strike plate and the flanges of the cup are touching the strike plate on both the front and back side (Fig. D.44). If it does not sit on the jounce bumper strike plate correctly, the cup swivels on the main plate. Rotate or move the cup to obtain this condition.



Make sure the cup is seated onto the jounce bumper strike plate forward and behind the axle.

fig. D.44

3. Position the U-bolt around the leaf spring assembly and insert in the hole closest to the leaf spring stack (Fig. D.45). The lower bracket flanges must be locked on the front and rear of the stock U-bolts holding the leaf springs to the axle.



Use closest hole to the leaf spring.

fig. D.45

4. Cap U-bolts with two 3/8" flat washers (V), and two 3/8"-16 nylon lock nuts (U) and evenly tighten only enough to draw the bracket up against the stock U-bolt at this time (Fig. D.46). Repeat for the other side. Make sure the bracket rests against the stock U-bolts (Fig. D.47).



Evenly tighten only enough to draw the lower bracket to the Stock U-bolts at this time.

fig. D.46

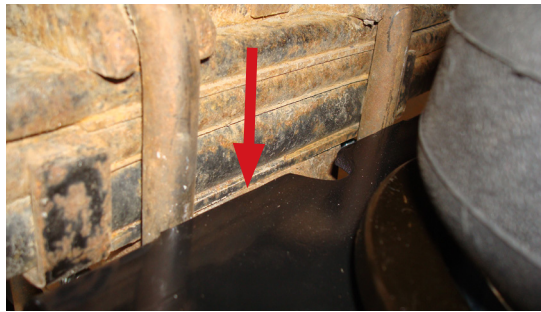

Bracket must be up against the stock U-bolts and the flanges of the lower bracket must be locked forward and behind the stock U-bolts.

fig. D.47

5. Insert the remaining 3/8"-16 x 10" carriage bolts (DD) through the remaining square hole in the lower bracket (forward of the axle) opposite of the one previously installed during the air spring assembly. Set the clamp bar (G) over the carriage bolts (DD) and cap with two 3/8" flat washers (V) and 3/8"-16 nylon lock nuts (U) (Fig. D.48). Repeat for the opposite side. Leave loose at this time.

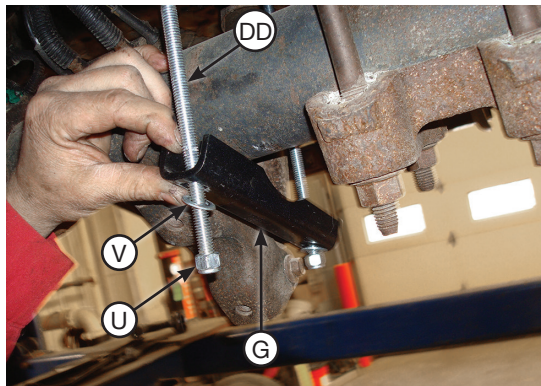

Set the axle clamp bar over the 3/8"-16 x 10" carriage bolts (DD) and cap with 3/8" flat washers (V) and 3/8"-16 nylon lock nuts (U). Leave loose at this time.

fig. D.48

- Tighten the axle clamp bar hardware evenly until it touches the axle (see note below). Torque the axle clamp bar bolts to 16 lb.-ft. (22Nm) (Fig. D.49). Repeat for the opposite side. Trim the 3/8"-16 x 10" carriage bolts below the nylon lock nuts if necessary.

**CAUTION**

DO NOT PINCH THE HARD BRAKE LINE ON THE PASSENGER'S SIDE WHILE TIGHTENING.

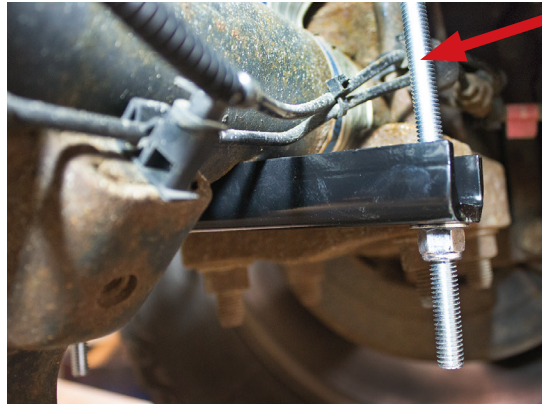

It may be necessary on some models to not tighten the axle clamp bar evenly on the passenger's (right) side so that the clamp bar will clear the hard brake line.

fig. D.49

- Torque the leaf spring U-bolt hardware to 10 lb.-ft. (14Nm). Repeat for the opposite side. Once tight, the upper and lower brackets will not be parallel and may look like they are out of alignment. This condition will be OK because of the way the lower bracket and upper bracket mounts are designed. Some variance from one unit to another is considered normal.
- Raise the axle up all the way (if not already done so) and remove the jack stands or equivalent used during the installation.
- Tie together the soft and hard brake lines that are close to the lower air spring roll plate on the driver's side with the large zip tie (VV) (Fig. D.50).



fig. D.50

10. Remove the two bolts that hold the emergency brake cable wire brackets to the frame on the driver's side and install the two emergency brake cable spacer brackets to the frame using the existing hardware removed. The emergency brake cable secondary bracket (XX) installs the farthest back on the driver's side frame (Fig. D.51). The emergency brake cable primary bracket (YY) installs in the forward location on the driver's side frame rail (Fig. D.52). Use two 5/16"-18 x 1" bolts (TT), four 5/16 flat washers (II) and two nylon lock nuts (UU) to attach the stock emergency brake wire brackets to both spacer brackets installed.



Install the smaller emergency brake secondary cable bracket the farthest back on the driver side frame.

fig. D.51

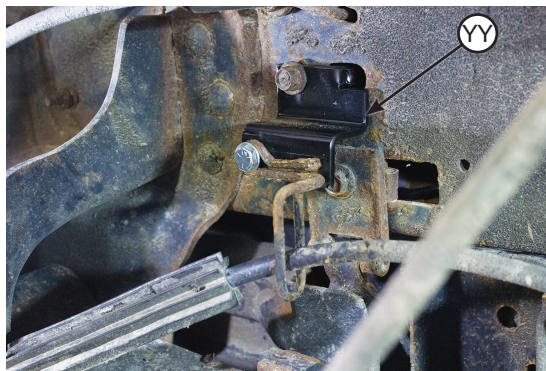

The larger emergency brake primary cable bracket installs in the forward position on the driver side frame.

fig. D.52

11. Install the P-clamp (WW) around the emergency brake cable (Fig. D.53). Attach it to the lower bracket with the 5/16"-18 x 1" carriage bolt previously installed on the driver's side lower bracket with one 5/16" flat washer (FF) and a 5/16"-18 nylon lock nut (UU). Tighten securely.



The P-clamp must point down under the lower bracket.

fig. D.53

E. Installing the Air Lines

This section explains how to set up the air spring kit to be controlled with Schrader valves and a separate compressed air source. An on-board air compressor system allows for hassle-free control of the air springs. Learn more about Air Lift control systems at www.airliftcompany.com/products/compressor-systems.

1. Choose a convenient location for mounting the inflation valves. Popular locations for the inflation valve are:
 - a. The wheel well flanges
 - b. The license plate recess in bumper
 - c. Under the gas cap access door
 - d. Through the license plate

NOTE

Whatever the chosen location, make sure there is enough clearance around the inflation valves for an air chuck.

2. Drill 5/16" holes to install the inflation valves.

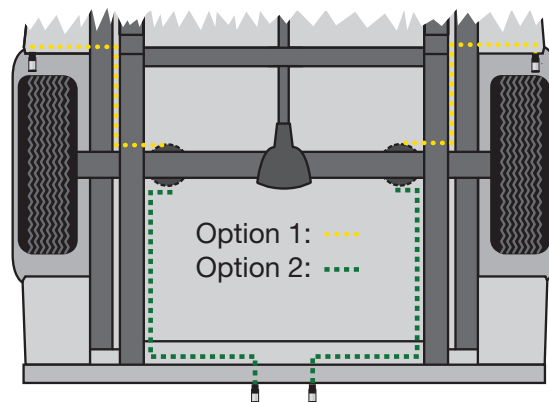

fig. E.1

3. To install dual air lines, cut the air line assembly in two equal lengths.
4. Place a 5/16" nut and star washer on the air valve. Leave enough of the inflation valve in front of the nut to extend through the hole and have room for the rubber washer, flat washer, and 5/16" nut and cap. There should be enough valve exposed after installation – approximately 1/2" – to easily apply a pressure gauge or an air chuck (Fig. E.2).

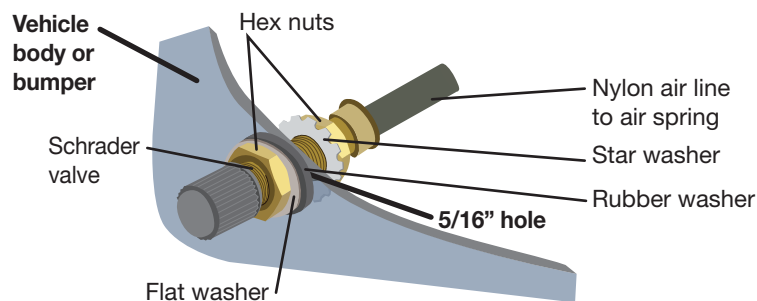

fig. E.2

5. Push the inflation valve through the hole and use the rubber washer, flat washer, and another 5/16" nut to secure it in place. Tighten the nuts to secure the assembly.

- Route the air line along the frame to the fitting on the air spring (Fig. E.1). Keep AT LEAST 6" of clearance between the air line and the exhaust system. Avoid sharp bends and edges. Use plastic tie straps to secure the air line to fixed points along the chassis. Be sure that the tie straps are tight, but do not pinch the air line. Leave at least 2" of slack to allow for any movement that might pull on the air line.
- Cut off the air line, leaving approximately 12" of extra air line. A clean square cut will prevent leaks. Insert the air line into the air fitting. This is a push-to-connect fitting. (9/16" of air line should be in the fitting).

TECH TIP

Wiggle the hose back and forth while inserting to make sure the hose bottoms out in the fitting to obtain a good seal.

TIPS FOR INSTALLING AIR LINES

When cutting air lines, use a sharp knife or a hose cutter and make clean, square cuts (Fig. E.3). Do not use scissors or wire cutters because these tools may deform the air line, causing it to leak around fittings. Do not cut the lines at an angle.

Do not bend the 1/4" hose at a radius of less than 1" or bend the 3/8" hose at a radius of less than 1 1/2". Do not put side load pressure on fitting. The hose should be straight beyond the fitting for 1" before bending.

Inspect hose for scratches that run lengthwise on hose prior to installation. Contact Air Lift customer service at (800) 248-0892 if the air line is damaged.



To watch a video demonstrating proper air line cutting, go to air-lift.co/cuttingairline.

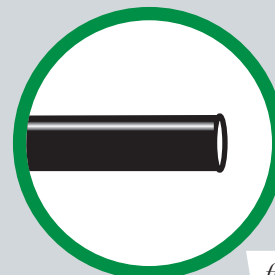

fig. E.3



INSTALLING THE HEAT SHIELD

- Bend tabs to provide a dead air space between exhaust pipe and heat shield. (Fig. E.4) Attach the heat shield to the exhaust pipe using the clamps. Bend the heat shield for maximum clearance to the air spring.

NOTE

Some vehicles have large resonators in this area; it will be necessary to double up on the clamps to fit these models (Fig. E.4).

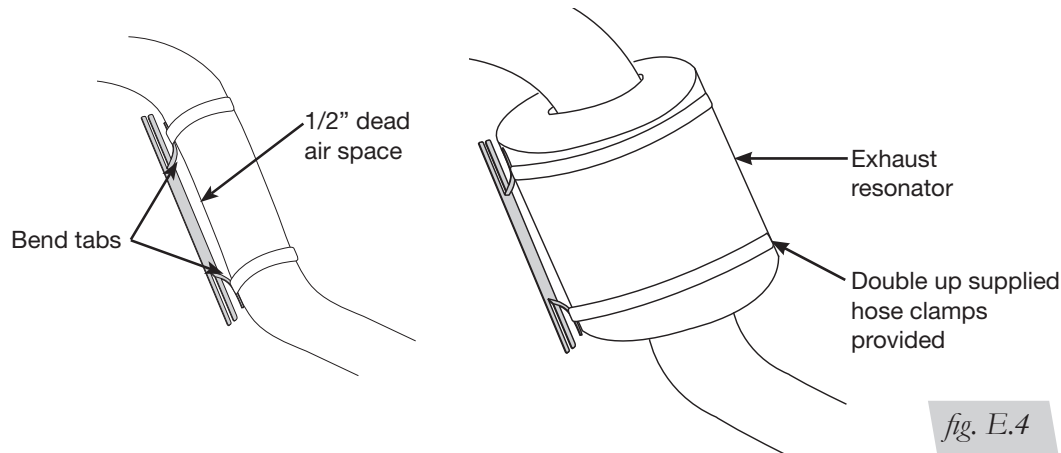

fig. E.4

F. Finished Installation Photos

1. The following images show the finished installation of both sides. (Figs. F.1, F.2, F.3 & F.4)



Back, left (driver's side)
rear view of the kit installed.

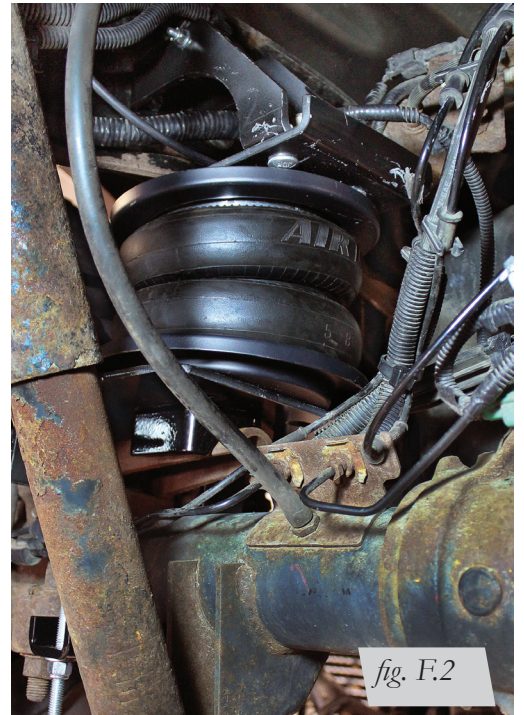

Back center, left (driver's side)
rear view of the kit installed.



Back right (passenger's side)
rear view of the kit installed.



Forward, center view of the passenger's side of
the kit installed.

G. Before Operating

CHECKING FOR LEAKS

1. Inflate the air spring to 30 PSI.
2. Spray all connections and the inflation valves with a solution of 1/5 liquid dish soap and 4/5 water. Spot leaks easily by looking for bubbles in the soapy water.
3. After the test, deflate the springs to the minimum pressure required to restore the system to normal ride height. Do not deflate to lower than 5 PSI.
4. Check the air pressure again after 24 hours. A 2-4 PSI loss after initial installation is normal. Retest for leaks if the loss is more than 5 PSI.

FIXING LEAKS

1. If there is a problem with the swivel fitting:
 - a. Check the air line connection by deflating the spring and removing the line by pulling the collar against the fitting and pulling firmly on the air line. Trim 1" off the end of the air line. Be sure the cut is clean and square (see Fig. E.3). Reinsert the air line into the push-to-connect fitting.
 - b. Check the threaded connection by tightening the swivel fitting another half turn. If it still leaks, deflate the air spring, remove the fitting, and re-coat the threads with thread sealant. Reinstall by hand tightening as much as possible and then use a wrench for an additional two turns.
2. If there is a problem with the inflation valve:
 - a. Check the valve core by tightening it with a valve core tool.
 - b. Check the air line by removing the air line from the barbed type fitting. Cut the air line off a few inches in front of the fitting and use a pair of pliers or vice grips to pull/twist the air line off of the fitting.

 **CAUTION**

DO NOT CUT OFF THE AIR LINE COMPLETELY AS THIS WILL USUALLY NICK THE BARB AND RENDER THE FITTING USELESS.

3. If the preceding steps have not resolved the problem, call Air Lift customer service at **(800) 248-0892**.

INSTALLATION CHECKLIST

- Clearance test** — Inflate the air springs to 75-90 PSI and make sure there is at least 1/2" clearance from anything that might rub against each sleeve. Be sure to check the tire, brakes, frame, shock absorbers and brake cables.
- Leak test before road test** — Inflate the air springs to 75-90 PSI and check all connections for leaks. All leaks must be eliminated before the vehicle is road tested.
- Heat test** — Be sure there is sufficient clearance from heat sources, at least 6" for air springs and air lines. If a heat shield was included in the kit, install it. If there is no heat shield, but one is required, call Air Lift customer service at **(800) 248-0892**.
- Fastener test** — Recheck all bolts for proper torque.
- Road test** — The vehicle should be road tested after the preceding tests. Inflate the springs to recommended driving pressures. Drive the vehicle 10 miles and recheck for clearance, loose fasteners and air leaks.
- Operating instructions** — If professionally installed, the installer should review the operating instructions with the owner. Be sure to provide the owner with all of the paperwork that came with the kit.

POST-INSTALLATION CHECKLIST

- Overnight leak down test** — Recheck air pressure after the vehicle has been used for 24 hours. If the pressure has dropped more than 5 PSI, then there is a leak that must be fixed. Either fix the leak yourself or return to the installer for service.
- Air pressure requirements** — It is important to understand the air pressure requirements of the air spring system. Regardless of load, the air pressure should always be adjusted to maintain adequate ride height at all times while driving.
- Thirty-day or 500-mile test** — Recheck the air spring system after 30 days or 500 miles, whichever comes first. If any part shows signs of rubbing or abrasion, the source should be identified and moved, if possible. If it is not possible to relocate the cause of the abrasion, the air spring may need to be remounted. If professionally installed, the installer should be consulted. Check all fasteners for tightness.

H. Product Use, Maintenance and Servicing

Minimum Recommended Pressure	Maximum Air Pressure
5 PSI	100 PSI

MAINTENANCE GUIDELINES

NOTE

By following the steps below, vehicle owners will obtain the longest life and best results from their air springs.

1. Check air pressure weekly.
2. Always maintain normal ride height. Never inflate beyond 100 PSI.
3. If you develop an air leak in the system, use a soapy water solution (1/5 liquid dish soap and 4/5 water) to check all air line connections and the inflation valve core before deflating and removing the air spring.



FOR SAFETY AND TO PREVENT POSSIBLE DAMAGE TO THE VEHICLE, DO NOT EXCEED MAXIMUM GROSS VEHICLE WEIGHT RATING (GVWR), AS INDICATED BY THE VEHICLE MANUFACTURER. ALTHOUGH THE AIR SPRINGS ARE RATED AT A MAXIMUM INFLATION PRESSURE OF 100 PSI, THE AIR PRESSURE ACTUALLY NEEDED IS DEPENDENT ON LOAD AND GVWR.

4. Loaded vehicles require at least 25 PSI. A “loaded vehicle” refers to a vehicle with a heavy bed load, a trailer or both. Never exceed GVWR, regardless of air spring, air pressure or other load assist. The springs in this kit will support approximately 40 pounds of load (combined on both springs) for each 1 PSI of pressure. The required air pressure will vary depending on the state of the original suspension. Operating the vehicle below the minimum air spring pressure will void the Air Lift warranty.
5. When increasing load, always adjust air pressure to maintain normal ride height. Increase or decrease pressure from the system as necessary to attain normal ride height for optimal ride and handling. Remember that loads carried behind the axle (including tongue loads) require more leveling force (pressure) than those carried directly over the axle.
6. Always add air to springs in small quantities, checking the pressure frequently.
7. Should it become necessary to raise the vehicle by the frame, make sure the system is at minimum pressure (5 PSI) to reduce the tension on the suspension/ brake components. Use of on-board leveling systems do not require deflation or disconnection.
8. Periodically check the air spring system fasteners for tightness. Also, check the air springs for any signs of rubbing. Realign if necessary.
9. On occasion, give the air springs a hard spray with a garden hose to remove mud, sand, gravel or other debris.

TUNING THE AIR PRESSURE

Pressure determination comes down to three things — level vehicle, ride comfort and stability.

1. Level vehicle

If the vehicle's headlights are shining into the trees or the vehicle is leaning to one side, then it is not level (Fig. H.1). Raise the air pressure to correct either of these problems and level the vehicle.

2. Ride comfort

If the vehicle has a rough or harsh ride it may be due to either too much pressure or not enough (Fig. H.2). Try different pressures to determine the best ride comfort.

3. Stability

Stability translates into safety and should be the priority, meaning the driver may need to sacrifice a perfectly level and comfortable ride. Stability issues include roll control, bounce, dive during braking and sponginess (Fig. H.3). Tuning out these problems usually requires an increase in pressure.

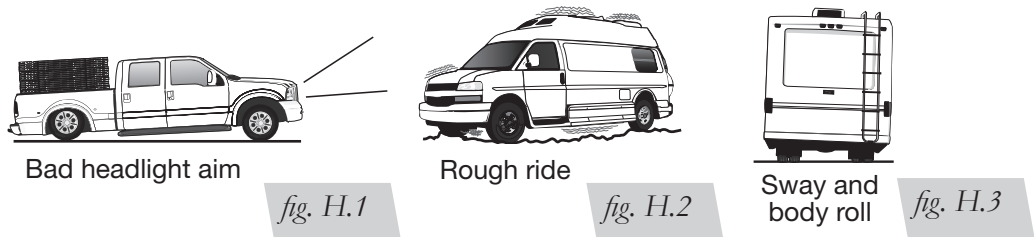

GUIDELINES FOR ADDING AIR

1. Start with the vehicle level or slightly above.
2. When in doubt, always add air.
3. If the front of the vehicle dives while braking, increase the pressure in the front air bags, if equipped.
4. If it is ever suspected that the air bags have bottomed out, increase the pressure (Fig. H.4).
5. Adjust the pressure up and down to find the best ride.
6. If the vehicle rocks and rolls, adjust the air pressure to reduce movement.
7. It may be necessary to maintain different pressures on each side of the vehicle. Loads such as water, fuel, and appliances will cause the vehicle to be heavier on one side (Fig. H.5). As much as a 50 PSI difference is not uncommon.

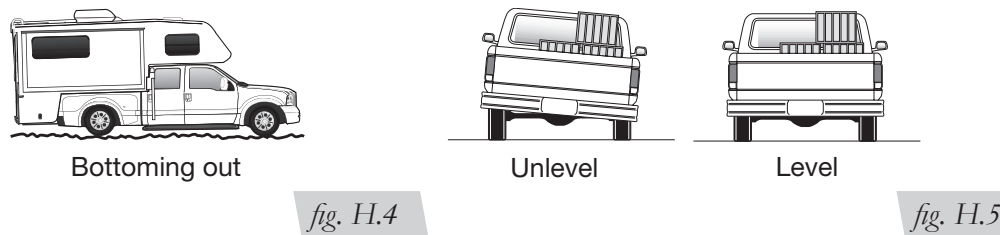

I. Troubleshooting Guide

PROBLEM	CAUSE	SOLUTION
System won't maintain pressure overnight.	Improperly installed air line, air line has holes or cracks.	Leak test the air line connections, the threaded connection into the air spring, and all fittings in the control system.
Corner won't raise or air leak develops.	Look for a kink or fold in the air line.	Replace any air line that has been kinked.

FREQUENTLY ASKED QUESTIONS

Q. Will installing air springs increase the weight ratings of a vehicle?

No. Adding air springs will not change the weight ratings (GAWR, GCWR and/or GVWR) of a vehicle. Exceeding the GVWR is dangerous and voids the Air Lift warranty.

Q. Is it necessary to keep air in the air springs at all times and how much pressure will they need?

For LoadLifter 7500 XL, the recommended minimum air pressure is 5 PSI, but it can safely be run at zero air pressure unladen (no load).

Q. Is it necessary to add a compressor system to the air springs?

No. Air pressure can be adjusted with any type of compressor as long as it can produce sufficient pressure to service the springs. Even a bicycle tire pump can be used, but it's a lot of work.

Q. How long should air springs last?

If the air springs are properly installed and maintained they can last indefinitely.

Q. Will raising the vehicle on a hoist for service work damage the air springs?

No. The vehicle can be lifted on a hoist for short-term service work such as tire rotation or oil changes. However, if the vehicle will be on the hoist for a prolonged period of time, support the axle with jack stands in order to take the tension off of the air springs.



Notes

Notes

Limited Warranty and Return Policy

Air Lift Company provides a limited lifetime warranty to the original purchaser of its Load Support products, that the products will be free from defects in workmanship and materials when used on cars and trucks as specified by Air Lift Company and under normal operating conditions, subject to the requirements and exclusions set forth in the full Limited Warranty and Return Policy that is available online at www.airliftcompany.com/warranty.

For additional warranty information contact Air Lift Company customer service.

Replacement Part Information

If replacement parts are needed, contact the local dealer or call Air Lift customer service at **(800) 248-0892**. Most parts are immediately available and can be shipped the same day.

Contact Air Lift Company customer service at (800) 248-0892 first if:

- Parts are missing from the kit.
- Need technical assistance on installation or operation.
- Broken or defective parts in the kit.
- Wrong parts in the kit.
- Have a warranty claim or question.

Contact the retailer where the kit was purchased:

- If it is necessary to return or exchange the kit for any reason.
- If there is a problem with shipping if shipped from the retailer.
- If there is a problem with the price.

Contact Information

Mailing address	P.O. Box 80167 Lansing, MI 48908-0167
Shipping address for returns	2727 Snow Road Lansing, MI 48917
Phone	Toll free: (800) 248-0892 International: (517) 322-2144
Email	service@airliftcompany.com
Web address	www.airliftcompany.com

Need Help?

Contact Air Lift Company customer service department by calling (800) 248-0892.

For calls from outside the USA or Canada, dial (517) 322-2144.



Printed in the USA
BGL-0217

Thank you for purchasing Air Lift products — the professional installer's choice!

Air Lift Company • 2727 Snow Road • Lansing, MI 48917 or P.O. Box 80167 • Lansing, MI 48908-0167
Toll Free (800) 248-0892 • Local (517) 322-2144 • Fax (517) 322-0240 • www.airliftcompany.com