



LoadLIFTER 5000™

S E R I E S

Installation
Guide



2014-current Dodge/Ram 1500

Kits 57289 | 88289 | 89289

For maximum effectiveness and safety, please read these instructions completely before proceeding with installation.

IDENTIFYING THE DIFFERENCES BETWEEN KITS

Should you need to contact Air Lift customer service, you will need to know which kit you are inquiring about: standard LoadLifter 5000, LoadLifter 5000 Ultimate or LoadLifter 5000 Ultimate Plus. The kits are easily identifiable by looking at the roll plates and air lines.

- Standard **LoadLifter 5000** – Zinc-plated steel roll plates and black nylon air lines.
- LoadLifter 5000 Ultimate** – Black powder-coated roll plates and black nylon air lines.
- LoadLifter 5000 Ultimate Plus** – Stainless steel roll plates, braided stainless steel air lines, stainless steel air spring mounting hardware.

Air Lift offers two Ultimate Plus upgrade kits:

52300 - Braided stainless steel air line and fittings.

52301 - Stainless steel roll plates, air spring mounting hardware, braided stainless steel air lines and fittings.



LoadLifter 5000
silver zinc-plated steel
roll plate



LoadLifter 5000 Ultimate
black powder-coated
roll plate



LoadLifter 5000 Ultimate Plus
stainless steel
roll plate



LoadLifter 5000
nylon air line



LoadLifter 5000 Ultimate
nylon air line



LoadLifter 5000 Ultimate PLUS
braided stainless steel air line

TABLE OF CONTENTS

| | |
|---|-----------|
| Installation Diagram | 2 |
| Hardware and Tools Lists | 3 |
| Introduction | 4 |
| Important Safety Notice | 4 |
| Notation Explanation | 4 |
| Installing the LoadLifter 5000 Series System | 5 |
| Getting Started | 5 |
| Building the Air Spring Assemblies | 7 |
| Finished Assemblies | 9 |
| Attaching the Assemblies to the Frame | 9 |
| Installing the Air Lines | 11 |
| Installing Nylon Air Lines | 11 |
| Installing Braided Stainless Steel Air Lines | 12 |
| Installing the Heat Shield | 12 |
| Finished Installation Photos | 13 |
| Before Operating | 14 |
| Checking for Leaks | 14 |
| Fixing Leaks | 14 |
| Installation Checklist | 15 |
| Post-Installation Checklist | 15 |
| Product Use, Maintenance and Servicing | 16 |
| Minimum and Maximum Pressure | 16 |
| Maintenance Guidelines | 16 |
| Tuning the Air Pressure | 17 |
| Guidelines for Adding Air | 17 |
| Troubleshooting Guide | 18 |
| Frequently Asked Questions | 18 |
| Limited Warranty and Return Policy | 21 |
| Replacement Part Information | 21 |
| Contact Information | 21 |

Installation Diagram

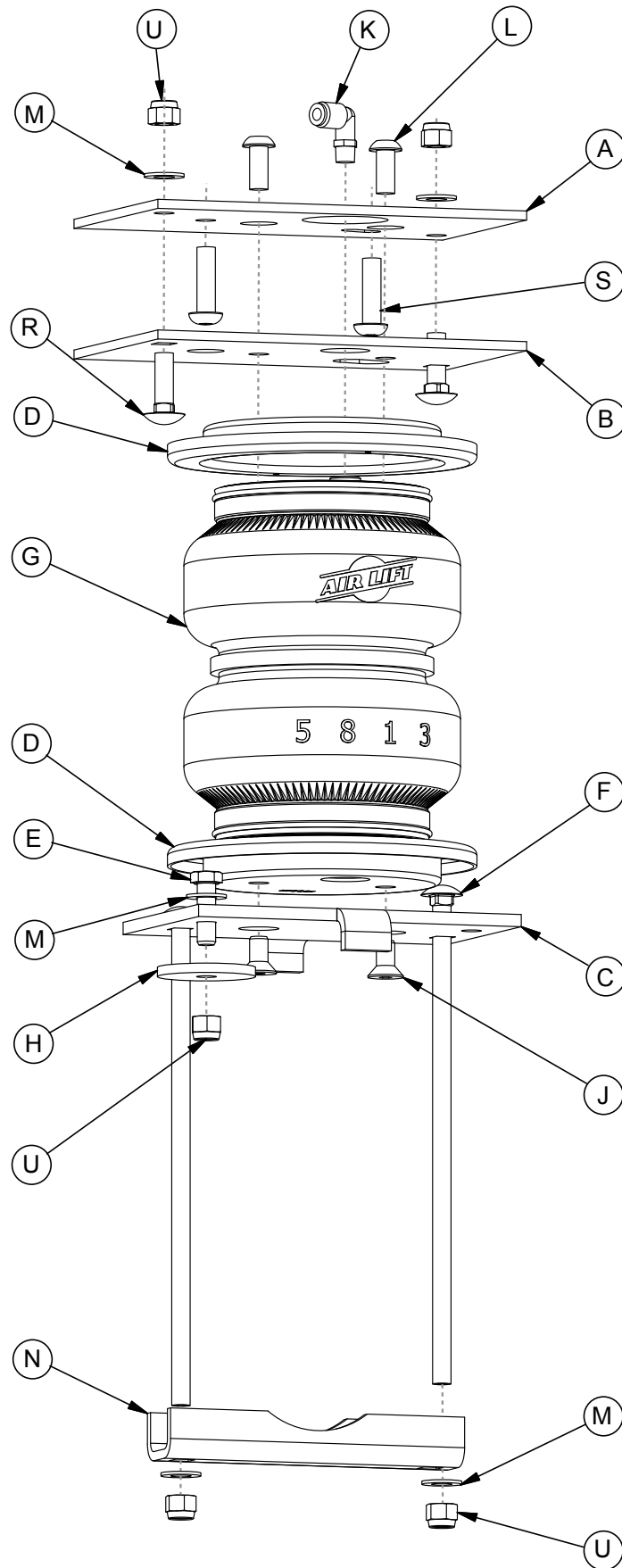

fig. 1

Hardware and Tools Lists

Common Parts Included in All 3 Kits

| Item | Part# | Description | Qty |
|------|-------|------------------------------------|-----|
| A | 07160 | Upper frame bracket..... | 2 |
| B | 07161 | Upper air spring bracket..... | 2 |
| C | 03019 | Lower bracket..... | 2 |
| E | 17188 | 3/8"-16 x 1.25" Hex-head bolt..... | 2 |
| F | 17387 | 3/8"-16 x 10" Carriage bolt..... | 4 |
| H | 18260 | Large flat washer..... | 2 |
| M | 18444 | 3/8" Flat washer..... | 10 |
| N | 01531 | Clamp bar | 2 |
| R | 17361 | 3/8"-16 x 1.25" Carriage bolt..... | 4 |
| S | 17366 | M10-1.5 Button-head screw | 4 |
| U | 18435 | 3/8"-16 Nylon lock nut..... | 10 |
| EE* | 21234 | Rubber washer..... | 2 |

* not pictured in the Installation Diagram

TOOLS LIST

| Description..... | Qty |
|--|-----|
| Standard and metric open-end or box wrenches | SET |
| Ratchet | 1 |
| Standard and metric, regular and deep-well sockets | SET |
| 5/16" drill bit (very sharp) | 1 |
| 9/16" Crows foot adapter..... | 1 |
| Heavy-duty drill | 1 |
| Torque wrench..... | 1 |
| Standard and metric hex-key wrenches | 1 |
| Hose cutter, razor blade or sharp knife..... | 1 |
| Hoist or floor jacks | 1 |
| Safety stands..... | 2 |
| Safety glasses | 1 |
| Air compressor or compressed air source | 1 |
| Spray bottle with dish soap/water solution..... | 1 |

The photos in this manual show the LoadLifter 5000 Ultimate kit.

Unique Parts in Each Kit

LoadLIFTER 5000™ KIT 57289

| Item | Part# | Description | Qty |
|------|-------|---------------------------------------|-----|
| D | 11951 | Roll plate (silver zinc plated) | 4 |
| G | 58437 | Air spring..... | 2 |
| J | 17215 | 3/8"-24 x 3/4" Flat-head screw..... | 4 |
| K | 21837 | Push-to-connect (PTC) fitting | 2 |
| L | 17365 | 3/8"-24 x 7/8" Button-head screw..... | 4 |
| AA* | 20086 | Air line | 1 |
| BB* | 10466 | Zip tie..... | 6 |
| CC* | 21230 | Valve cap..... | 2 |
| DD* | 18501 | M8 Flat washer..... | 2 |
| GG* | 21233 | 5/16" Hex nut | 4 |
| FF* | 18411 | Star washer | 2 |

LoadLIFTER 5000™ **ULTIMATE** KIT 88289

| Item | Part# | Description | Qty |
|------|-------|--|-----|
| D | 11967 | Roll plate (black powder coated) | 4 |
| G | 58496 | Air spring with jounce bumper | 2 |
| J | 17215 | 3/8"-24 x 3/4" Flat-head screw..... | 4 |
| K | 21837 | Push-to-connect (PTC) fitting | 2 |
| L | 17365 | 3/8"-24 x 7/8" Button-head screw..... | 4 |
| AA* | 20086 | Air line | 1 |
| BB* | 10466 | Zip tie..... | 6 |
| CC* | 21230 | Valve cap..... | 2 |
| DD* | 18501 | M8 Flat washer..... | 2 |
| GG* | 21233 | 5/16" Hex nut | 4 |
| FF* | 18411 | Star washer | 2 |

LoadLIFTER 5000™ **ULTIMATE PLUS+** KIT 89289

| Item | Part# | Description | Qty |
|------|-------|--|-----|
| D | 11880 | Roll plate (stainless steel)..... | 4 |
| G | 58496 | Air spring with jounce bumper..... | 2 |
| J | 17363 | 3/8"-24 x 3/4" Stainless steel flat-head screw | 4 |
| K | 21815 | AN type fitting | 2 |
| L | 17376 | 3/8"-24 x 7/8" Stainless steel button head screw .. | 4 |
| AA* | 20987 | Stainless steel braided air line | 2 |
| BB* | 10466 | Zip tie..... | 12 |
| HH* | 21709 | Fill valve with cap & nut | 2 |
| DD* | 18572 | M8 Stainless steel flat washer | 2 |
| FF* | 18623 | Stainless steel star washer | 2 |
| II* | 21813 | PTC to AN adapter fitting..... | 2 |
| JJ* | 20084 | Air line assembly..... | 1 |



Missing or damaged parts? Call Air Lift customer service at (800) 248-0892 for a replacement part.

Introduction

The purpose of this publication is to assist with the installation, maintenance and troubleshooting of the standard LoadLifter 5000, LoadLifter 5000 Ultimate or LoadLifter 5000 Ultimate Plus air spring kits. All LoadLifter 5000 Series kits utilize sturdy, reinforced, commercial-grade single or double, depending on the kit, convolute bellows. LoadLifter 5000 Ultimate kits add an internal jounce bumper and black powder-coated roll plates. LoadLifter 5000 Ultimate Plus kits also have an internal jounce bumper, but add stainless steel roll plates, air lines and air spring mounting hardware.

The air springs are manufactured like a tire with layers of rubber and cords that control growth. LoadLifter 5000 series kits are recommended for most 3/4- and 1-ton pickups and SUVs with leaf springs and provide up to 5,000 pounds of load-leveling support with air adjustability from 5-100 PSI.

It is important to read and understand the entire installation guide before beginning installation or performing any maintenance, service or repair.

Air Lift Company reserves the right to make changes and improvements to its products and publications at any time. For the latest version of this manual, contact Air Lift Company at **(800) 248-0892** or visit airliftcompany.com.

IMPORTANT SAFETY NOTICE

The installation of this kit does not alter the gross vehicle weight rating (GVWR) or payload of the vehicle. Check the vehicle's owner's manual and do not exceed the maximum load listed for this vehicle.

Gross vehicle weight rating: The maximum allowable weight of the fully loaded vehicle (including passengers and cargo). This number — along with other weight limits, as well as tire, rim size and inflation pressure data — is shown on the vehicle's Safety Compliance Certification Label.

Payload: The combined, maximum allowable weight of cargo and passengers that the truck is designed to carry. Payload is GVWR minus the base curb weight.

NOTATION EXPLANATION

Hazard notations appear in various locations in this publication. Information which is highlighted by one of these notations must be observed to help minimize risk of personal injury or possible improper installation which may render the vehicle unsafe. Notes are used to help emphasize areas of procedural importance and provide helpful suggestions. The following definitions explain the use of these notations as they appear throughout this guide.



INDICATES IMMEDIATE HAZARDS WHICH WILL RESULT IN SEVERE PERSONAL INJURY OR DEATH.



INDICATES HAZARDS OR UNSAFE PRACTICES WHICH COULD RESULT IN SEVERE PERSONAL INJURY OR DEATH.



INDICATES HAZARDS OR UNSAFE PRACTICES WHICH COULD RESULT IN DAMAGE TO THE MACHINE OR MINOR PERSONAL INJURY.

NOTE

Indicates a procedure, practice or hint which is important to highlight.

Installing the LoadLifter 5000 Series System

GETTING STARTED

1. Raise the vehicle and support the frame with jack stands, drop the axle down to make room for the air spring assemblies to be put into position between the frame and axle (Fig. 2).

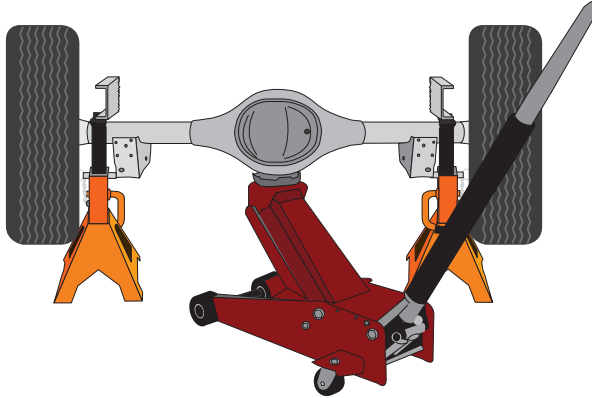

fig. 2

2. On the left (driver's) side axle there is a small vent tube (Fig. 3) that needs to be tied on an angle with a zip tie (BB).

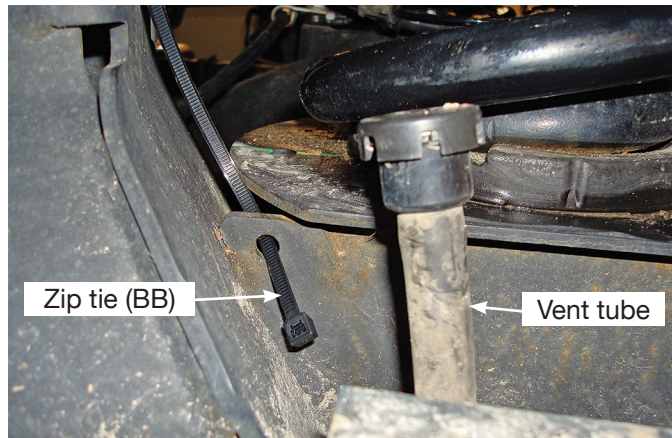

fig. 3

3. Insert the zip tie into the small hole in the lower coil spring seat, then around the vent tube and just snug the zip tie enough to angle the tube out of the way (Fig. 4).

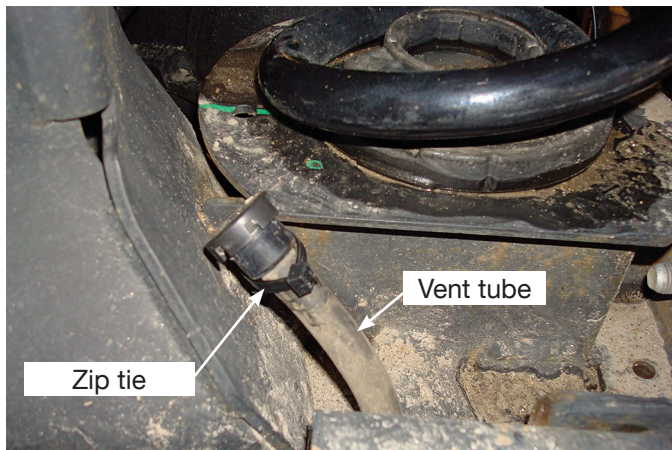
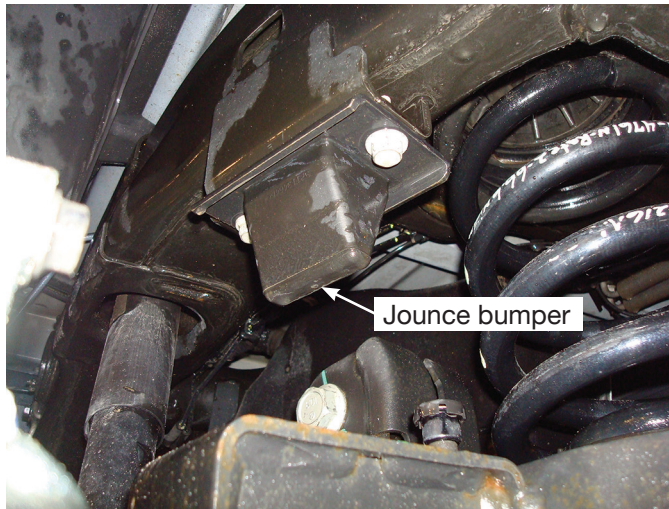
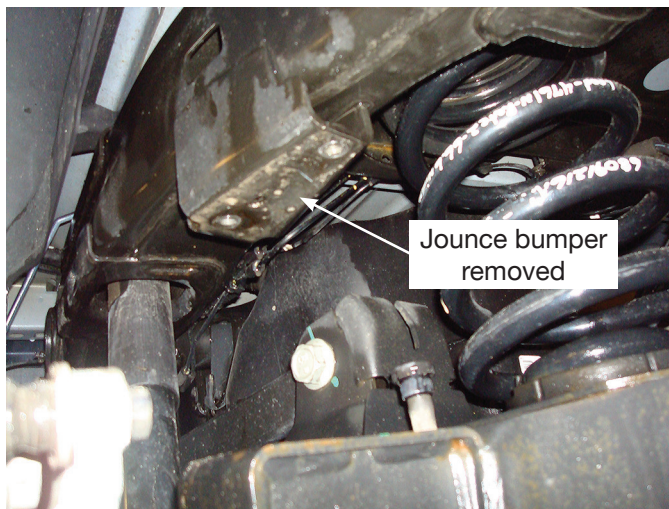

fig. 4

- Remove the left and right side jounce bumpers (Figs. 5 & 6).

fig. 5

fig. 6

- Attach the upper frame bracket (A) to the frame (Figs. 7 & 8) using the M10 button head screws (S).

NOTE

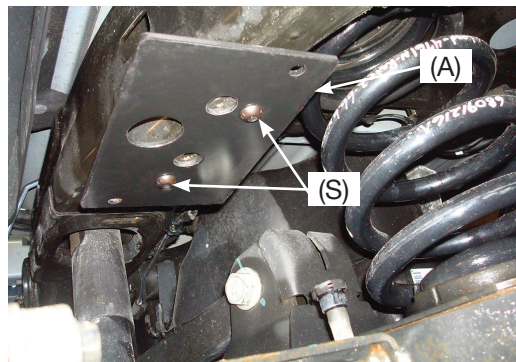
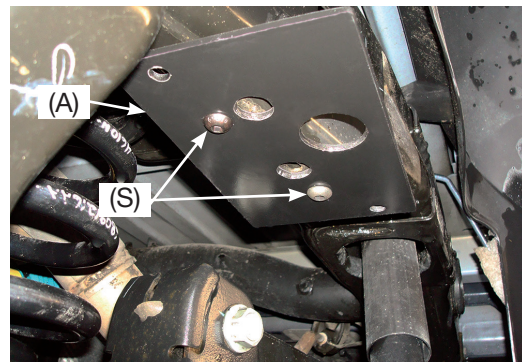
The large hole in the bracket goes to the outside of the frame (toward the tire).

Driver's side

fig. 7
Passenger's side

fig. 8

- Torque the mounting hardware to 30 lb.-ft. (41Nm)

BUILDING THE AIR SPRING ASSEMBLIES

1. Set a roll plate (D) over the top of each air spring (G).

NOTE

The radiused (rounded) edge of the roll plate (D) will be toward the air spring so that the air spring is seated inside both roll plates.

2. Install the swivel fitting (K) into the top of the air spring finger tight plus one and a half turns (Fig. 9). Repeat for both air springs.

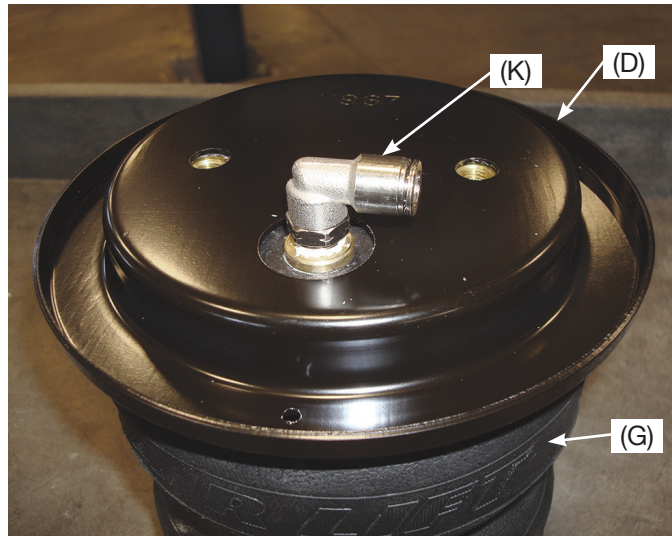

fig. 9

3. Set both air springs in front of you with the fittings pointing at you (Fig. 10).
4. Insert the 3/8" carriage bolt (R) through the upper air spring bracket (B) in the hole at the back side only (Figs. 1 & 10).

NOTE

The upper air spring brackets will be a mirror image when set onto the air springs (see Fig. 10).

Left (driver's side assembly

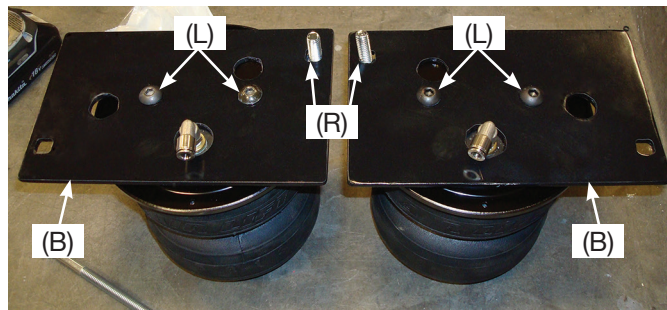

Right (passenger's side assembly

fig. 10

5. Set both brackets onto the air springs and attach using the 3/8" button head screws (L). Torque no more than 20 lb.-ft. (27Nm).

6. Install the thick 3/8" flat washer (H) onto the lower bracket (C) with 3/8" hex-head bolt (E), 3/8" flat washer (M) and 3/8" nylon lock nut (U) as shown (Figs. 1 & 11). Tighten securely.
7. Insert the long 3/8" carriage bolts (F) into the square holes in the lower bracket (Figs. 1 & 11).

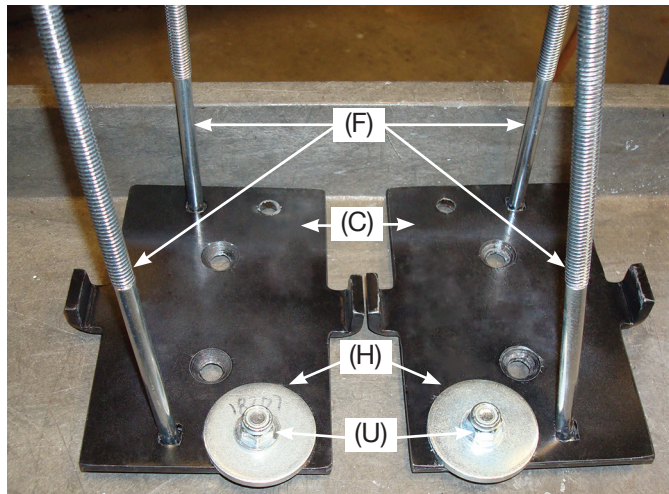
fig. 11

8. Set a roll plate (D) over the bottom of the air spring and install the lower brackets onto the air spring assembly so that the large washer previously installed will be forward of the axle once installed (Figs. 12 & 13) using the 3/8" flat head screws (J). Torque to no more than 20 lb-ft. (27Nm).

Left (driver's) side assembly

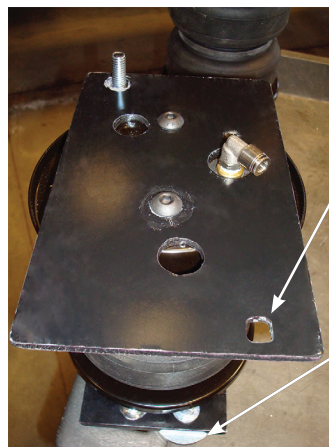
fig. 12

Make sure the lower bracket attached with the large washer is on the same side as the open square hole in the top bracket as shown.

The large washer installed on the lower bracket will be forward of the axle once installed.

Left (driver's) side assembly

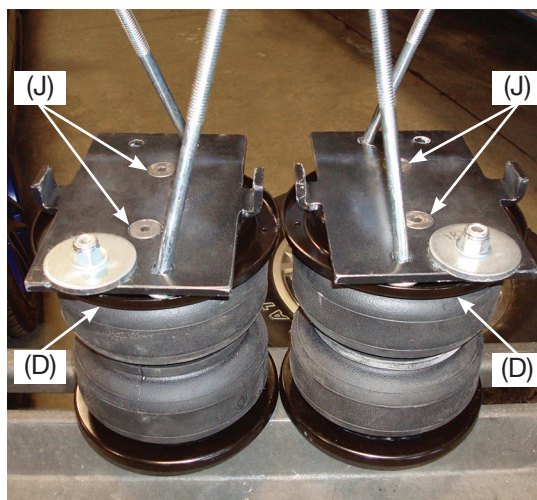

Right (passenger's) side assembly

See Figures 8 & 10 to position correctly on the assembly.

fig. 13

FINISHED ASSEMBLIES

Left (driver's)
side assembly



Right
(passenger's)
side assembly

fig. 14

ATTACHING THE ASSEMBLIES TO THE FRAME

1. With the axle slightly hanging, set the left (driver's) side assembly on the axle, making sure that the carriage bolt (F) goes in between the brake line and the axle (Fig. 15).



fig. 15

2. Carefully set the upper air spring bracket into position, making sure that the carriage bolt and fitting line up with the holes in the frame bracket (Fig. 16). Raise the axle up so that the brackets come together making sure the fitting and the carriage bolt go through the holes and do not bind.



fig. 16

3. Insert the remaining carriage bolt (R) through the open front holes from the bottom up and cap both upper carriage bolts with 3/8" flat washer (M) and 3/8" nylon lock nut (U). Torque to 16 lb.-ft. (22Nm). Repeat for the other side.

NOTE

It may be necessary to use a 9/16" crows foot adapter to torque the nut underneath the frame.

4. Bring the axle all the way up and position the lower bracket over the lower jounce bumper strike plate. The large washer on the bottom of the bracket should be positioned forward and over the lower jounce bumper strike plate (Fig. 17).



Large washer over the lower jounce bumper strike plate

Right
(passenger's)
side assembly

fig. 17

5. Set the clamp bar (N) over the two long carriage bolts (F) under the axle and cap with two 3/8" flat washers (M) and 3/8" nylon lock nuts (U) (Fig. 18).

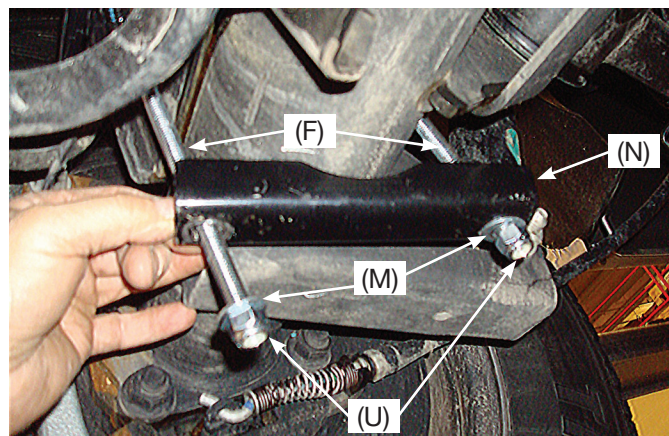

fig. 18

6. Torque evenly to 10 lb.-ft. (14Nm) (Fig. 19). Repeat for the other side.

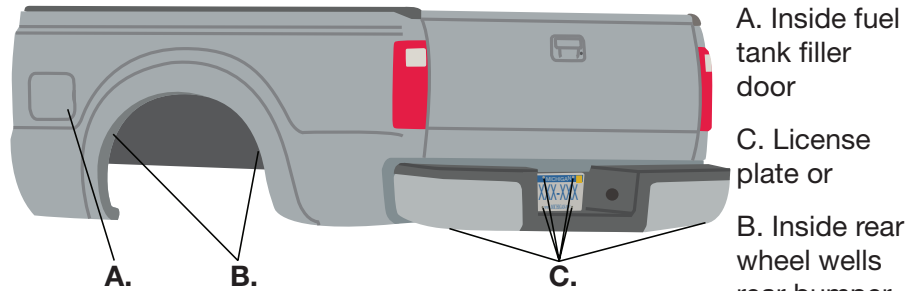

fig. 19

7. Raise the axle or lower the vehicle and remove the jack stands.

Installing the Air Lines

Air lines are routed from the air springs to Schrader valves. LoadLifter 5000 Series air lines come in two styles: nylon and braided stainless steel. Begin by choosing locations for the Schrader valves and drill a 5/16" hole, if necessary (Fig. 20).



* For LoadLifter Ultimate Plus kits, the recommended location for the Schrader valves is the rear bumper area or license plate.

fig. 20



KEEP AT LEAST 6" OF CLEARANCE BETWEEN ALL AIR LINES AND THE EXHAUST SYSTEM. AVOID SHARP BENDS AND EDGES.

INSTALLING NYLON AIR LINES

1. Cut the air line in half. Make clean, square cuts with a razor blade or hose cutter (Fig. 21). Do not use scissors or wire cutters.

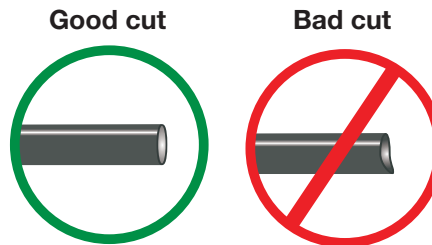

fig. 21

2. Use zip ties to secure the air line to fixed points along the chassis. Do not pinch or kink the air line. The minimum bend radius for the air line is 1". Leave at least 2" of slack in the air line to allow for any movement that might pull on the air line.
3. Install the Schrader valve in the chosen location (Fig. 22).

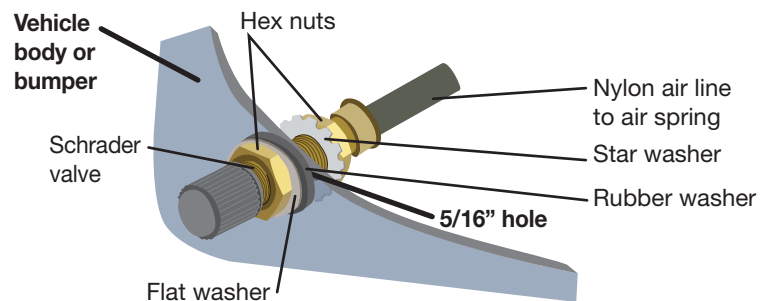

fig. 22

INSTALLING BRAIDED STAINLESS STEEL AIR LINES

CAUTION

KEEP THE AIR LINE AWAY FROM THE FUEL LINE, BRAKE LINES AND ELECTRICAL WIRES.

1. Use zip ties to secure the air line to fixed points along the chassis every 6" to 8". Leave at least 2" of slack to allow for any movement that might pull on the air line.
2. Tighten the air line hex nut finger tight, then use 2 wrenches to turn 1 additional flat (1/6 of one full turn). **Do not overtighten** (Figs. 23 or 24). The easiest way to tighten the fitting is off the vehicle. Install the Schrader valve in the chosen location.
3. Coil and secure any excess air line in an area where it will not be susceptible to damage. The braided stainless steel air line cannot be trimmed.

Air Line Setup Without Compressor System

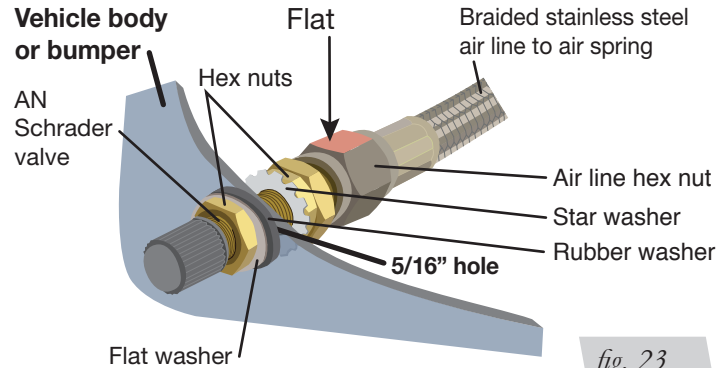

fig. 23

Air Line Setup for Compressor Integration

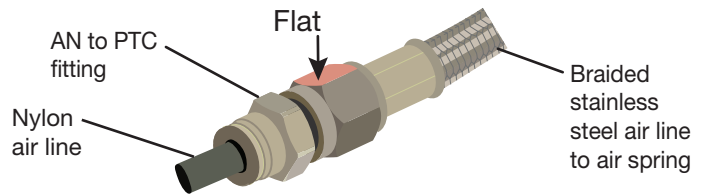

fig. 24

Finished Installation Photos

1. The following images show the finished installation of both sides. (Figs. 25-28).



Left (driver's) side top view

fig. 25

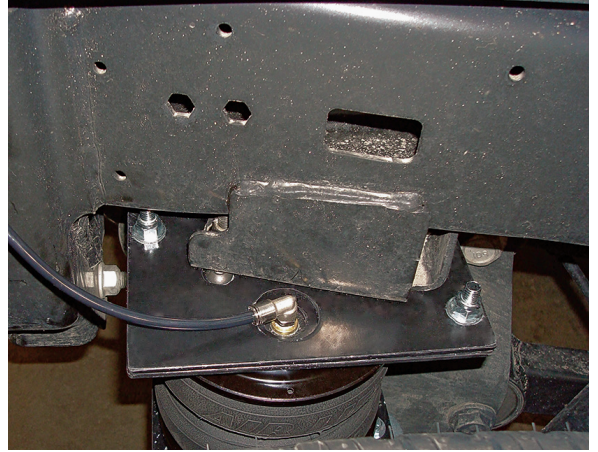

Right (passenger's) side top view

fig. 26

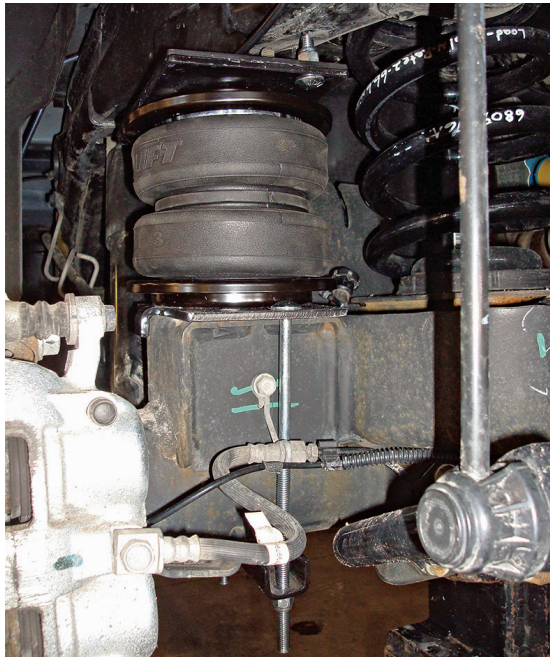

Left (driver's) side back view shown with tire removed

fig. 27

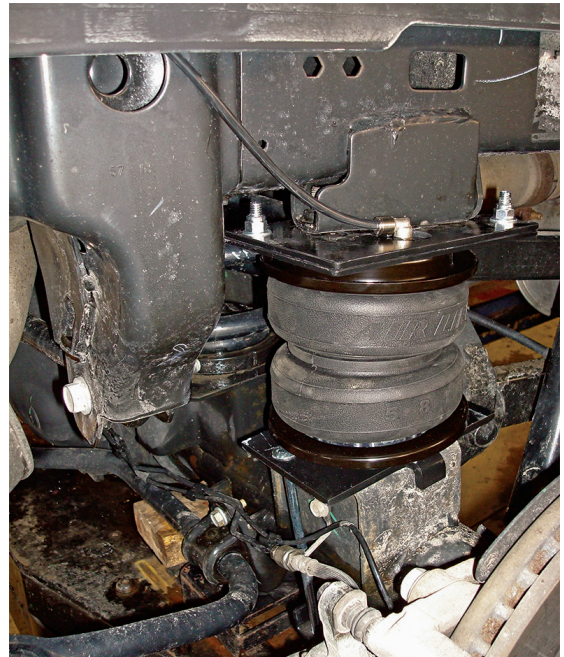

Right (passenger's) side view shown with tire removed

fig. 28

Before Operating

CHECKING FOR LEAKS

1. Inflate the air spring to 30 PSI.
2. Spray all connections and the inflation valves with a solution of 1/5 liquid dish soap and 4/5 water. Spot leaks easily by looking for bubbles in the soapy water.
3. After the test, deflate the springs to the minimum pressure required to restore the system to normal ride height. Do not deflate to lower than 5 PSI.
4. Check the air pressure again after 24 hours. A 2-4 PSI loss after initial installation is normal. Retest for leaks if the loss is more than 5 PSI.

FIXING LEAKS

1. If there is a problem with the swivel fitting:
 - a. Check the air line connection by deflating the spring and removing the line by pulling the collar against the fitting and pulling firmly on the air line. Trim 1" off the end of the air line. Be sure the cut is clean and square (see Fig. 21). Reinsert the air line into the push-to-connect fitting.
 - b. Check the threaded connection by tightening the swivel fitting another half turn. If it still leaks, deflate the air spring, remove the fitting, and re-coat the threads with thread sealant. Reinstall by hand tightening as much as possible and then use a wrench for an additional two turns.
2. If there is a problem with the inflation valve:
 - a. Check the valve core by tightening it with a valve core tool.
 - b. Check the air line by removing the air line from the barbed type fitting. Cut the air line off a few inches in front of the fitting and use a pair of pliers or vice grips to pull/twist the air line off of the fitting.

DO NOT CUT OFF THE AIR LINE COMPLETELY AS THIS WILL USUALLY NICK THE BARB AND RENDER THE FITTING USELESS.

3. If the preceding steps have not resolved the problem, call Air Lift customer service at **(800) 248-0892**.

INSTALLATION CHECKLIST

- Clearance test** — Inflate the air springs to 75-90 PSI and make sure there is at least 1/2" clearance from anything that might rub against each sleeve. Be sure to check the tire, brakes, frame, shock absorbers and brake cables.
- Leak test before road test** — Inflate the air springs to 75-90 PSI and check all connections for leaks. All leaks must be eliminated before the vehicle is road tested.
- Heat test** — Be sure there is sufficient clearance from heat sources, at least 6" for air springs and air lines. If a heat shield was included in the kit, install it. If there is no heat shield, but one is required, call Air Lift customer service at **(800) 248-0892**.
- Fastener test** — Recheck all bolts for proper torque.
- Road test** — The vehicle should be road tested after the preceding tests. Inflate the springs to recommended driving pressures. Drive the vehicle 10 miles and recheck for clearance, loose fasteners and air leaks.
- Operating instructions** — If professionally installed, the installer should review the operating instructions with the owner. Be sure to provide the owner with all of the paperwork that came with the kit.

POST-INSTALLATION CHECKLIST

- Overnight leak down test** — Recheck air pressure after the vehicle has been used for 24 hours. If the pressure has dropped more than 5 PSI, then there is a leak that must be fixed. Either fix the leak yourself or return to the installer for service.
- Air pressure requirements** — It is important to understand the air pressure requirements of the air spring system. Regardless of load, the air pressure should always be adjusted to maintain adequate ride height at all times while driving.
- Thirty-day or 500-mile test** — Recheck the air spring system after 30 days or 500 miles, whichever comes first. If any part shows signs of rubbing or abrasion, the source should be identified and moved, if possible. If it is not possible to relocate the cause of the abrasion, the air spring may need to be remounted. If professionally installed, the installer should be consulted. Check all fasteners for tightness.

Product Use, Maintenance and Servicing

| Minimum Recommended Pressure | Maximum Air Pressure |
|------------------------------|----------------------|
| 5 PSI | 100 PSI |

MAINTENANCE GUIDELINES

NOTE

By following the steps below, vehicle owners will obtain the longest life and best results from their air springs.

1. Check air pressure weekly.
2. Always maintain normal ride height. Never inflate beyond 100 PSI.
3. If the system develops an air leak, use a soapy water solution (1/5 liquid dish soap and 4/5 water) to check all air line connections and the inflation valve core before deflating and removing the air spring.

CAUTION

FOR SAFETY AND TO PREVENT POSSIBLE DAMAGE TO THE VEHICLE, DO NOT EXCEED MAXIMUM GROSS VEHICLE WEIGHT RATING (GVWR), AS INDICATED BY THE VEHICLE MANUFACTURER. ALTHOUGH THE AIR SPRINGS ARE RATED AT A MAXIMUM INFLATION PRESSURE OF 100 PSI, THE AIR PRESSURE ACTUALLY NEEDED IS DEPENDENT ON LOAD AND GVWR.

4. Loaded vehicles require at least 25 PSI. A “loaded vehicle” refers to a vehicle with a heavy bed load, a trailer or both. Never exceed GVWR, regardless of air spring, air pressure or other load assist. The springs in this kit will support approximately 40 pounds of load (combined on both springs) for each 1 PSI of pressure. The required air pressure will vary depending on the state of the original suspension. Operating the vehicle below the minimum air spring pressure will void the Air Lift warranty.
5. When increasing load, always adjust air pressure to maintain normal ride height. Increase or decrease pressure from the system as necessary to attain normal ride height for optimal ride and handling. Remember that loads carried behind the axle (including tongue loads) require more leveling force (pressure) than those carried directly over the axle.
6. Always add air to springs in small quantities, checking the pressure frequently.
7. Should it become necessary to raise the vehicle by the frame, make sure the system is at minimum pressure (5 PSI) to reduce the tension on the suspension/ brake components. Use of on-board leveling systems do not require deflation or disconnection.
8. Periodically check the air spring system fasteners for tightness. Also, check the air springs for any signs of rubbing. Realign if necessary.
9. On occasion, give the air springs a hard spray with a garden hose to remove mud, sand, gravel or other debris.

TUNING THE AIR PRESSURE

Pressure determination comes down to three things — level vehicle, ride comfort and stability.

1. Level vehicle

If the vehicle's headlights are shining into the trees or the vehicle is leaning to one side, then it is not level (Fig. 29). Raise the air pressure to correct either of these problems and level the vehicle.

2. Ride comfort

If the vehicle has a rough or harsh ride it may be due to either too much pressure or not enough (Fig. 30). Try different pressures to determine the best ride comfort.

3. Stability

Stability translates into safety and should be the priority, meaning the driver may need to sacrifice a perfectly level and comfortable ride. Stability issues include roll control, bounce, dive during braking and sponginess (Fig. 31). Tuning out these problems usually requires an increase in pressure.

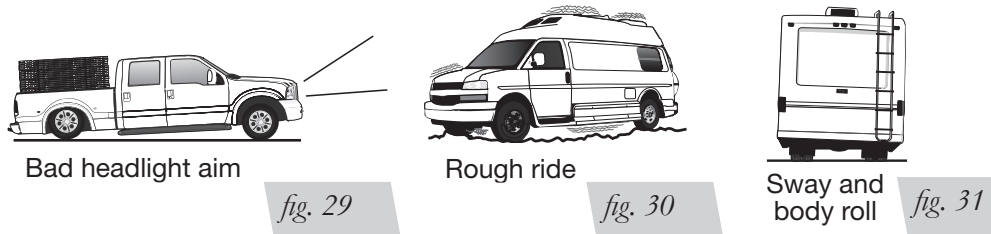

GUIDELINES FOR ADDING AIR

1. Start with the vehicle level or slightly above.
2. When in doubt, always add air.
3. If the front of the vehicle dives while braking, increase the pressure in the front air bags, if equipped.
4. If it is ever suspected that the air bags have bottomed out, increase the pressure (Fig. 32).
5. Adjust the pressure up and down to find the best ride.
6. If the vehicle rocks and rolls, adjust the air pressure to reduce movement.
7. It may be necessary to maintain different pressures on each side of the vehicle. Loads such as water, fuel, and appliances will cause the vehicle to be heavier on one side (Fig. 33). As much as a 50 PSI difference is not uncommon.

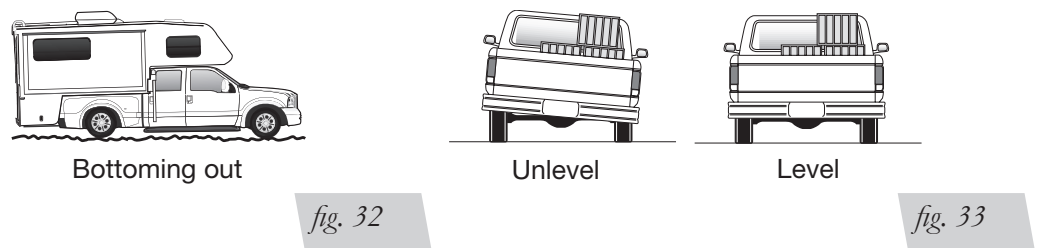

Troubleshooting Guide

| PROBLEM | CAUSE | SOLUTION |
|---|--|--|
| System won't maintain pressure overnight. | Improperly installed air line, air line has holes or cracks. | Leak test the air line connections, the threaded connection into the air spring, and all fittings in the control system. |
| Air spring or air line leak. | Fitting seal or air line is compromised. | Check to make sure air lines are seated in connectors. Inspect fittings with soapy water. Trim hose or re-seal fitting. Ensure lines are cut straight. |
| Corner won't raise or air leak develops. | Look for a kink or fold in the air line. | Replace any air line that has been kinked. |

FREQUENTLY ASKED QUESTIONS

Q. Will installing air springs increase the weight ratings of a vehicle?

No. Adding air springs will not change the weight ratings (GAWR, GCWR and/ or GVWR) of a vehicle. Exceeding the GVWR is dangerous and voids the Air Lift warranty.

Q. Is it necessary to keep air in the air springs at all times and how much pressure will they need?

For LoadLifter 5000 standard, Ultimate and Ultimate Plus, the recommended minimum air pressure is 5 PSI, but it can safely be run at zero air pressure unladen (no load).

Q. Is it necessary to add a compressor system to the air springs?

No. Air pressure can be adjusted with any type of compressor as long as it can produce sufficient pressure to service the springs. Even a bicycle tire pump can be used, but it's a lot of work.

Q. How long should air springs last?

If the air springs are properly installed and maintained they can last indefinitely.

Q. Will raising the vehicle on a hoist for service work damage the air springs?

No. The vehicle can be lifted on a hoist for short-term service work such as tire rotation or oil changes. However, if the vehicle will be on the hoist for a prolonged period of time, support the axle with jack stands in order to take the tension off of the air springs.



Notes



Notes



Limited Warranty and Return Policy

Air Lift Company provides a limited lifetime warranty to the original purchaser of its Load Support products, that the products will be free from defects in workmanship and materials when used on cars and trucks as specified by Air Lift Company and under normal operating conditions, subject to the requirements and exclusions set forth in the full Limited Warranty and Return Policy that is available online at www.airliftcompany.com/warranty.

For additional warranty information contact Air Lift Company customer service.

Replacement Part Information

If replacement parts are needed, contact the local dealer or call Air Lift customer service at **(800) 248-0892**. Most parts are immediately available and can be shipped the same day.

Contact Air Lift Company customer service at (800) 248-0892 first if:

- Parts are missing from the kit.
- Need technical assistance on installation or operation.
- Broken or defective parts in the kit.
- Wrong parts in the kit.
- Have a warranty claim or question.

Contact the retailer where the kit was purchased:

- If it is necessary to return or exchange the kit for any reason.
- If there is a problem with shipping if shipped from the retailer.
- If there is a problem with the price.

Contact Information

| | |
|-------------------------------------|--|
| Mailing address | P.O. Box 80167 Lansing, MI 48908-0167 |
| Shipping address for returns | 2727 Snow Road Lansing, MI 48917 |
| Phone | Toll free: (800) 248-0892 International: (517) 322-2144 |
| Email | service@airliftcompany.com |
| Web address | www.airliftcompany.com |



Thank you for purchasing Air Lift Products — the Authorized Installer's choice!

Need Help?

**Contact Air Lift Company Customer Service at (800) 248-0892
or email service@airliftcompany.com.**

For calls outside the U.S. or Canada, dial (517) 322-2144.