

RideCONTROL

by AIR LIFT®

Kit No. 59518



*Cover
illustration
may not depict
actual kit.*



INSTALLATION GUIDE

For maximum effectiveness and safety, please read these instructions completely before proceeding with installation.

Failure to read these instructions can result in an incorrect installation.

TABLE OF CONTENTS

- Introduction 2**
 - Important Safety Notice 2
 - Notation Explanation 2

- Installation Diagram 3**
 - Hardware List 3
 - Tools List 4

- Getting Started. 4**
 - Getting Started 4
 - Important Notes 4
 - Ride Height and Clearance Distance 4
 - Raising the Vehicle 5
 - Assembling the Installation Tool 5

- Installing the RideControl System. 5**
 - Positioning the Upper Bracket 5
 - Attaching the Lower Bracket 6
 - Attaching the Upper Bracket 6
 - Mounting the Air Spring 7
 - Installing the Air Lines 7
 - Installing the Heat Shield 9
 - Checking for Leaks 9
 - Fixing Leaks 9

- Before Operating 10**
 - Installation Checklist 10
 - Post-Installation Checklist 10

- Product Use, Maintenance and Servicing 10**
 - Minimum and Maximum Pressure 10
 - Maintenance Guidelines 11
 - Troubleshooting Guide 11
 - Frequently Asked Questions 11
 - Tuning the Air Pressure 12
 - Guidelines for Adding Air 12

- Warranty and Returns Policy 13**

- Replacement Parts and Returns 14**

- Replacement Information 14**

- Contact Information 15**

Introduction

The purpose of this publication is to assist with the installation, maintenance and troubleshooting of the RideControl air spring kit. The air springs used in RideControl kits are designed and manufactured like a tire. The air springs have layers of rubber and cords that control the bag's growth and funnel it into one direction. The bags do not require a coil spring for control. RideControl kits utilize a sleeve style air bag that provides up to 2,000 pounds of load-leveling support. Each sleeve is rated at a maximum of 100 p.s.i.

It is important to read and understand the entire installation guide before beginning installation or performing any maintenance, service or repair. The information here includes a hardware list, tool list, step-by-step installation information, maintenance tips, safety information and a troubleshooting guide.

Air Lift Company reserves the right to make changes and improvements to its products and publications at any time. Contact Air Lift Company at (800) 248-0892 for the latest version of this manual.

IMPORTANT SAFETY NOTICE

The installation of this kit does not alter the Gross Vehicle Weight Rating (GVWR) or payload of the vehicle. Check your vehicle's owner's manual and do not exceed the maximum load listed for your vehicle.

Gross Vehicle Weight Rating: The maximum allowable weight of the fully loaded vehicle (including passengers and cargo). This number — along with other weight limits, as well as tire, rim size and inflation pressure data — is shown on the vehicle's Safety Compliance Certification Label.

Payload: The combined, maximum allowable weight of cargo and passengers that the truck is designed to carry. Payload is GVWR minus the Base Curb Weight.

NOTATION EXPLANATION

Hazard notations appear in various locations in this publication. Information which is highlighted by one of these notations must be observed to help minimize risk of personal injury or possible improper installation which may render the vehicle unsafe. Notes are used to help emphasize areas of procedural importance and provide helpful suggestions. The following definitions explain the use of these notations as they appear throughout this guide.



DANGER

INDICATES IMMEDIATE HAZARDS WHICH WILL RESULT IN SEVERE PERSONAL INJURY OR DEATH.



WARNING

INDICATES HAZARDS OR UNSAFE PRACTICES WHICH COULD RESULT IN SEVERE PERSONAL INJURY OR DEATH.



CAUTION

INDICATES HAZARDS OR UNSAFE PRACTICES WHICH COULD RESULT IN DAMAGE TO THE MACHINE OR MINOR PERSONAL INJURY.

NOTE

Indicates a procedure, practice or hint which is important to highlight.

Installation Diagram

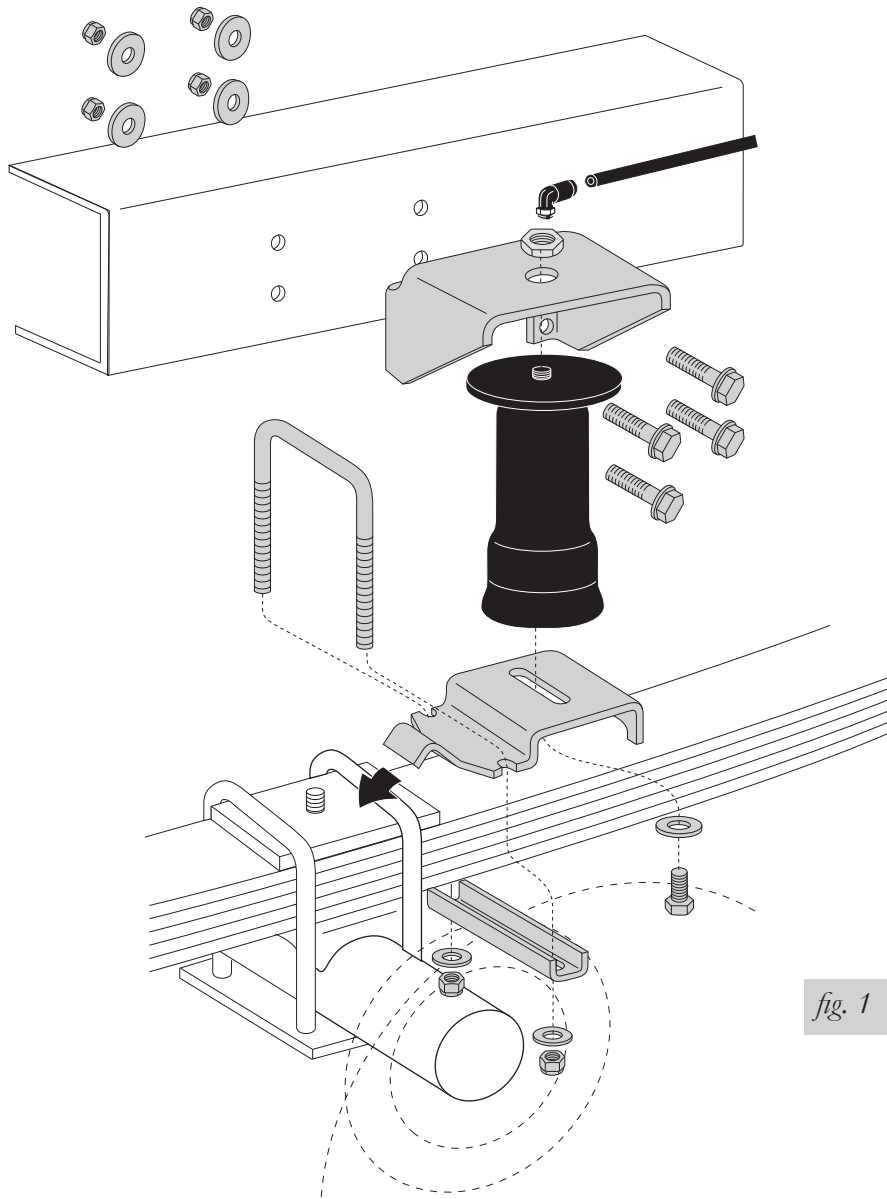

HARDWARE LIST

Item	Part #	Description.....Qty	Item	Part #	Description.....Qty
A	58987	Air spring.....2	L	18444	3/8" Flat washer4
B	07940	Upper bracket2	M	18414	1/2" Flat washer2
C	03616	Lower bracket2	N	18447	3/8" Oversized washer8
D	10591	Installation tool.....1	AA	20216	Air line 16'1
E	21837	Elbow fitting2	BB	10466	Tie strap.....6
F	10583	3/8" U-bolt2	CC	21230	Valve cap2
G	01426	Clamp bar2	DD	18405	5/16" Flat washer2
H	17159	Washer head frame bolt.....8	EE	21234	Rubber washer.....2
I	17124	1/2" Hex head cap screw2	FF	18411	Star washer.....2
J	18454	Pal nut.....3	GG	21233	5/16" Hex nut4
K	18435	3/8" Nyloc nut.....12			



Missing or damaged parts? Call Air Lift customer service at (800) 248-0892 for a replacement part.

TOOLS LIST

Description.....	Qty	Description.....	Qty
Hoist or floor jacks.....	1	Ratchet with 9/16", metric, & 1/2" deep well sockets.....	1
Safety stands.....	2	3/8" and 5/16" drill bits (very sharp).....	2
Safety glasses.....	1	Heavy duty drill.....	1
Torque wrench.....	1	Hose cutter, razor blade, or sharp knife.....	1
5/16" open-end or box wrench.....	1	Air compressor or compressed air source.....	1
7/16" open-end or box wrench.....	1	Spray bottle with dish soap/water solution.....	1
9/16" open-end or box wrench.....	1		
Crescent wrench.....	1		

Getting Started

IMPORTANT NOTES

Your vehicle may be equipped with a rear brake proportioning valve. Any type of load assist product could effect brake performance. We recommend that you check with your dealer before installing this type of product. If your vehicle DOES NOT have a rear brake proportioning valve or is equipped with an anti-lock type brake system, installation of a load assist product will have NO EFFECT on brake system performance.



COMPRESSED AIR CAN CAUSE INJURY AND DAMAGE TO THE VEHICLE AND PARTS IF IT IS NOT HANDLED PROPERLY. FOR YOUR SAFETY, DO NOT TRY TO INFLATE THE AIR SLEEVES UNTIL THEY HAVE BEEN PROPERLY SECURED TO THE VEHICLE.

Your air springs will last much longer if they are not the suspension limiter in either compression or extension. Regardless of load, the air pressure should always be adjusted so that the normal ride height is maintained at all times. The shock absorber is usually the limiter on extension. If this is not the case, you should consider the use of limiting straps, especially if the vehicle is used off-road.

RIDE HEIGHT AND CLEARANCE DISTANCE

- Determine the normal ride height. The normal ride height is the distance between the bottom edge of the wheel-well and the center of the hub. In some cases, the normal ride height is not perfectly level.
 - Remove unusual loads and examine your vehicle from the side to ensure it is on a level surface.
 - If necessary, use a jack to raise the rear end so that the vehicle achieves the original "as delivered" ride height.
- Measure the distance between the center of the hub and the bottom edge of the wheel well (fig. 2). This is normal ride height. Record the measurement below:
Normal ride height: _____ inches
- Measure the distance between the frame and the tire. This kit requires a MINIMUM of 5" of clearance for a FULLY INFLATED air spring (fig. 3).

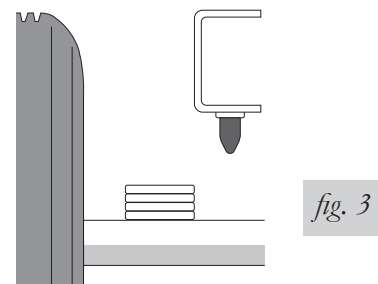
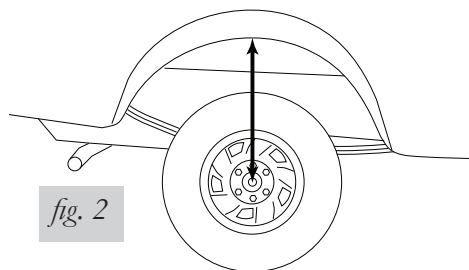

RAISING THE VEHICLE

1. Raise the vehicle with a hoist or jack stands and remove the wheels (fig. 4).

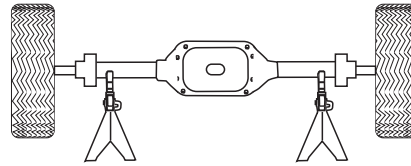

fig. 4

ASSEMBLING THE INSTALLATION TOOL

1. The tool provided with this kit will assist in proper setup and alignment of the air spring and will also position the upper bracket for drilling the bolt holes. The tool attaches to the upper and lower brackets and is rigid so that it will self-align the upper bracket. The threaded section of the upper part of the tool ensures that the air spring can only be mounted at the correct height. The air spring will work throughout the entire threaded range on the tool. Correct placement depends on the particular vehicle application.
2. Secure the upper bracket (B) to the installation tool (D) using the provided nylon nut (F) (fig. 5).
 - a. **1987 and older Chevy/GMC 4WD only:** The upper bracket must be installed with the legs of the upper bracket “legs up”. Refer to fig. 6.
3. Loosely attach the tool to the lower bracket (C) using $\frac{1}{2}$ ” flat washer (H) and $\frac{1}{2}$ ” bolt (G). Refer to fig. 5. Leave loose for adjustment.

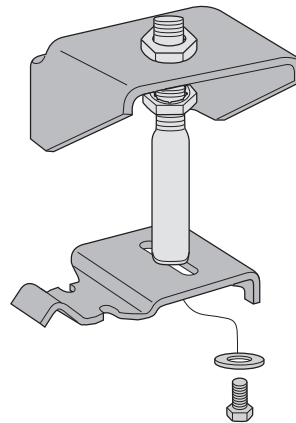

fig. 5

Installing the RideControl System

POSITIONING THE UPPER BRACKET

1. Set the assembly on the leaf spring FORWARD of the axle.
2. Using the slot in the lower bracket, push the upper bracket against the frame rail. Use the pal nuts on the threaded portion of the installation tool to adjust the upper bracket so that the legs are flat against the frame rail and all four mounting holes are on the middle section of the frame rail. The mounting holes must NOT fall on the rounded edges of the frame rail.

NOTE

You must also allow AT LEAST 1.5” above the top of the upper bracket for air fitting clearance. The brackets can be mounted anywhere within the threaded range of the installation tool.

3. On some models it will be necessary to trim the inner body flange to allow the air spring to be mounted at the recommended height of 5.5-7” with 1.5” clearance for the air fitting. The threaded section of the installation tool ensures that the air spring can only be mounted at correct height.

NOTE

The passenger side has A/C heater lines on some models. It will be necessary to clear the lines so no damage results from trimming the inner body flange.

4. Mark the area of the body flange that will need to be removed and, using a die grinder or tin snips, cut away the marked area.
5. On the driver side of some models there may be a bolt protruding through the frame that may rub on the air spring. The bolt will prevent the upper bracket from laying flush to the frame rail. It will be necessary to remove the bolt or trim it flush. The other clips will sufficiently hold the lines to the frame rail.

ATTACHING THE LOWER BRACKET

1. With the hook end of the lower bracket placed over the stock u-bolt (fig. 6), secure the lower bracket to the leaf spring with the provided u-bolts, clamp bar, flat washers and lock nuts. Torque to 20 ft/lbs.

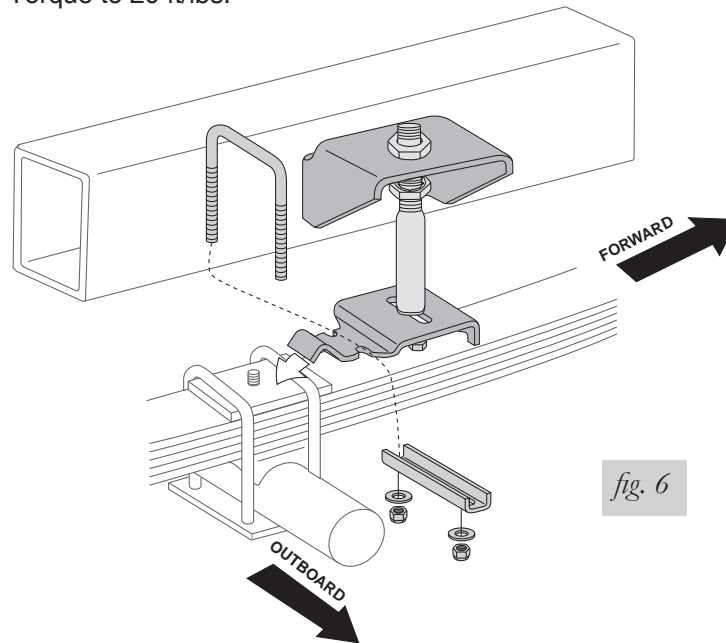
**ATTACHING THE UPPER BRACKET**

1. Using the upper bracket as a template, centerpunch one of the lower mounting holes and drill a 3/8" hole through the frame. (fig. 7)

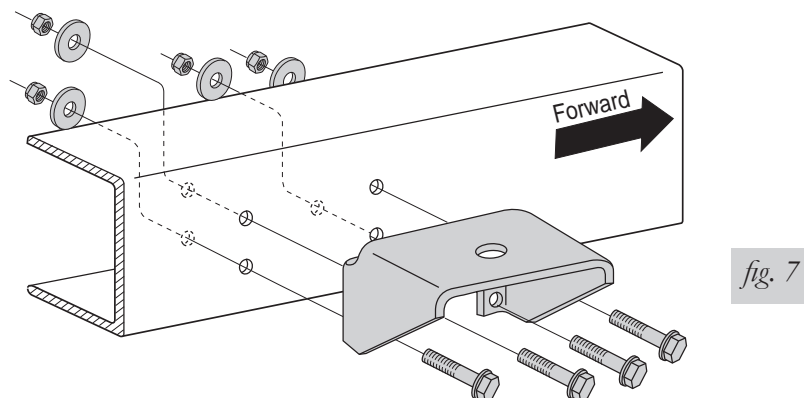
**CAUTION**

BEFORE DRILLING, CHECK THE BACK SIDE OF THE FRAME FOR CLEARANCE ISSUES SUCH AS, BRAKE LINES, GAS LINES, ELECTRICAL LINES, ETC. ANY OBSTACLES WILL NEED TO BE TEMPORARILY RELOCATED TO CLEAR THE AREA.

2. Install one of the washer head frame bolts and loosely attach the 3/8" oversized flat washer and lock nut.
3. Centerpunch and drill a 3/8" hole through the other lower mounting hole. Do not insert the mounting bolt at this time.
4. Remove the installation tool by removing the upper pal nut, loosening and removing the tool from the bottom bolt (leave in place) and slightly rotating the upper bracket to give enough clearance to completely remove the tool. Save the upper pal nut.
5. Rotate the upper bracket back to the original location and install the washer head frame bolt, 3/8" oversized flat washer, and lock nut through the second lower mounting hole. Tighten both of the installed fasteners to 20 ft/lbs.
6. Center punch and drill the upper mounting holes and install the fasteners.

MOUNTING THE AIR SPRING

1. Install the air fitting into the top of the air spring. This fitting is pre-coated with sealant. Tighten the fitting finger-tight plus two complete turns with a 7/16" open end wrench. Be careful to tighten on the metal hex nut only and DO NOT overtighten. (fig. 8)

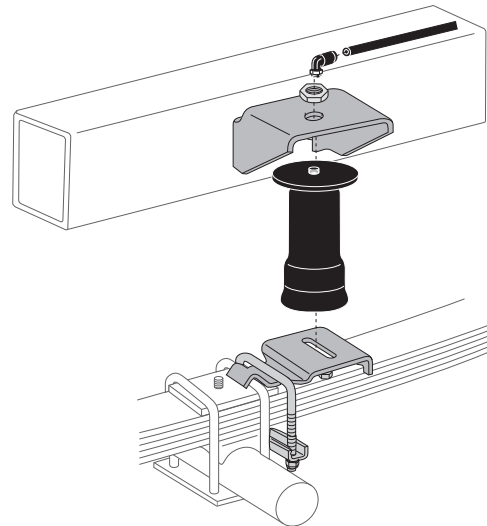

2. Guide the upper thread post/fitting through the center mounting hole in the upper bracket.
3. Attach the air spring to the lower bracket. Carefully hand turn the air spring onto the lower mounting bolt. Leave loose for later adjustment.
4. Install the pal nut, flange up, onto the upper thread post of the air spring. Leave loose for later adjustment.

INSTALLING THE AIR LINES

1. Choose a convenient location for mounting the inflation valves. Popular locations for the inflation valve are:
 - a. The wheel well flanges.
 - b. License plate recess in bumper.
 - c. Under the gas cap access door.
 - d. Through license plate itself.

NOTE

Whatever the chosen location is, make sure there is enough clearance around the inflation valves for an air chuck.

2. Drill a 5/16" hole to install the inflation valves.
3. Cut the air line assembly (AA) in two equal lengths.

CAUTION

WHEN CUTTING OR TRIMMING THE AIR LINE, USE A HOSE CUTTER, A RAZOR BLADE, OR A SHARP KNIFE. A CLEAN, SQUARE CUT WILL ENSURE AGAINST LEAKS. DO NOT USE WIRE CUTTERS OR SCISSORS TO CUT THE AIR LINE. THESE TOOLS MAY FLATTEN OR CRIMP THE AIR LINE CAUSING IT TO LEAK AROUND THE O-RING SEAL INSIDE THE ELBOW FITTING (FIG. 9).

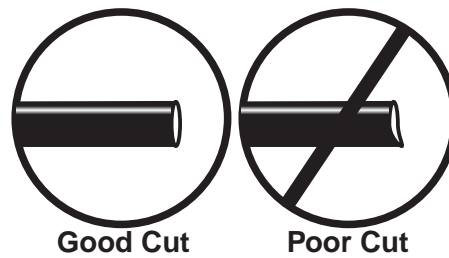

fig. 9

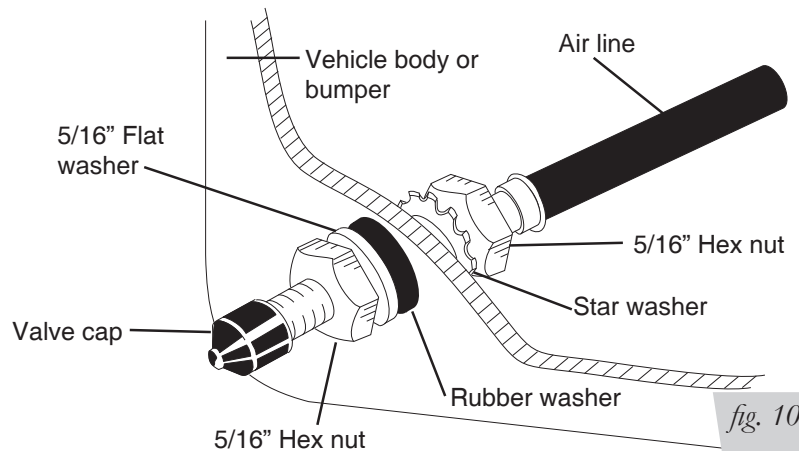

fig. 10

4. Place a 5/16" nut and star washer on the air valve. Leave enough of the inflation valve in front of the nut to extend through the hole and have room for the rubber washer, flat washer, and 5/16" nut and cap. There should be enough valve exposed after installation—approximately 1/2"—to easily apply a pressure gauge or an air chuck (fig. 10).
5. Push the inflation valve through the hole and use the rubber washer, flat washer, and another 5/16" nut to secure it in place. Tighten the nuts to secure the assembly.
6. Route the air line along the frame to the air fitting on the air spring (fig. 11). Keep AT LEAST 6" of clearance between the air line and heat sources, such as the exhaust pipes, muffler, or catalytic converter. Avoid sharp bends and edges. Use the plastic tie straps to secure the air line to fixed, non-moving points along the chassis. Be sure that the tie straps are tight, but do not pinch the air line. Leave at least 2" of slack to allow for any movement that might pull on the air line (fig. 11).

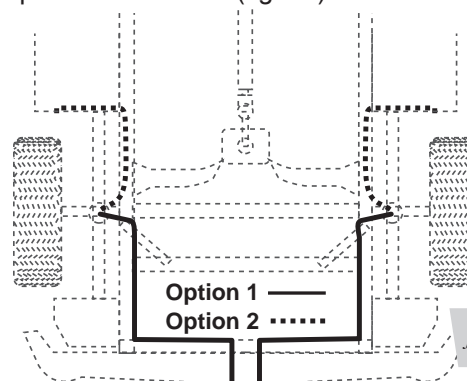

fig. 11

7. Cut off the air line, leaving approximately 12" of extra air line. A clean square cut will ensure against leaks. Insert the air line into the air fitting. This is a push-to-connect

fitting. Simply push the air line into the 90° swivel fitting until it bottoms out (9/16" of air line should be in the fitting).

8. Install the minimum/maximum air pressure decal in a highly visible location. We suggest placing the decal on the driver-side window, just above the door handle.

INSTALLING THE HEAT SHIELD

1. Bend tabs to provide a ½" dead air space between exhaust pipe and heat shield (fig. 12).
2. Attach the heat shield to the exhaust pipe using the clamps. Bend the heat shield for maximum clearance to the air spring (fig. 12).

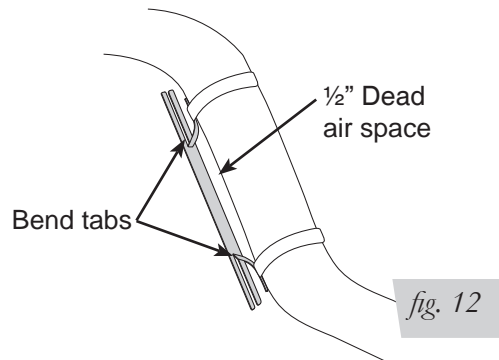

CHECKING FOR LEAKS

1. Inflate the air spring to 30 PSI.
2. Spray all connections and the inflation valves with a solution of 1/5 liquid dish soap and 4/5 water. Spot leaks easily by looking for bubbles in the soapy water.
3. After the test, deflate the springs to the minimum pressure required to restore the system to normal ride height. Do not deflate to lower than 5 PSI.
4. Check the air pressure again after 24 hours. A 2 - 4 PSI loss after initial installation is normal. Retest for leaks if the loss is more than 5 lbs.

FIXING LEAKS

1. If there is a problem with the swivel fitting:
 - a. Check the air line connection by deflating the spring and removing the line by pulling the collar against the fitting and pulling firmly on the air line. Trim 1" off the end of the air line. Be sure the cut is clean and square (see fig. 9). Reinsert the air line into the push-to-connect fitting.
 - b. Check the threaded connection by tightening the swivel fitting another ½ turn. If it still leaks, deflate the air spring, remove the fitting, and re-coat the threads with thread sealant. Reinstall by hand tightening as much as possible and then use a wrench for an additional two turns.
2. If there is a problem with the inflation valve:
 - a. Check the valve core by tightening it with a valve core tool.
 - b. Check the air line by removing the air line from the barbed type fitting. Cut the air line off a few inches in front of the fitting and use a pair of pliers or vice grips to pull/twist the air line off of the fitting.



CAUTION

DO NOT CUT OFF THE AIR LINE COMPLETELY AS THIS WILL USUALLY NICK THE BARB AND RENDER THE FITTING USELESS.

3. If the preceding steps have not resolved the problem, call Air Lift customer service at (800) 248-0892.

Before Operating

INSTALLATION CHECKLIST

- Clearance test — Inflate the air springs to 60 p.s.i. and make sure there is at least ½” clearance from anything that might rub against each sleeve. Be sure to check the tire, brake drum, frame, shock absorbers and brake cables.
- Leak test before road test — Inflate the air springs to 60 p.s.i. and check all connections for leaks. Refer to “Checking for Leaks” on page 9. All leaks must be eliminated before the vehicle is road tested.
- Heat test — Be sure there is sufficient clearance from heat sources, at least 6” for air springs and air lines. If a heat shield was included in the kit, install it. If there is no heat shield, but one is required, call Air Lift customer service at (800) 248-0892.
- Fastener test — Recheck all bolts for proper torque.
 - 3/8” Frame bolts..... 20 ft/lbs
 - U-bolt lock nuts 20 ft/lbs
 - Mounting bolt/pal nut..... 10 ft/lbs
- Road test — The vehicle should be road tested after the preceding tests. Inflate the springs to 10 p.s.i. or until the vehicle is level. Drive the vehicle 10 miles and recheck for clearance, loose fasteners and air leaks.
- Operating instructions — If professionally installed, the installer should review the operating instructions with the owner. Be sure to provide the owner with all of the paperwork that came with the kit.

Technician’s Signature _____

Date _____

POST-INSTALLATION CHECKLIST

- Overnight leak down test — Recheck air pressure after the vehicle has been used for 24 hours. If the pressure has dropped more than 5 p.s.i., then there is a leak that must be fixed. Either fix the leak yourself or return to the installer for service.
- Air pressure requirements — I understand the air pressure requirements of my air spring system. Regardless of load, the air pressure should always be adjusted to maintain ride height at all times.
- Thirty day or 500 mile test — I understand that I must recheck the air spring system after 30 days or 500 miles, whichever comes first. If any part shows signs of rubbing or abrasion, the source should be identified and moved, if possible. If it is not possible to relocate the cause of the abrasion, the air spring may need to be remounted. If professionally installed, the installer should be consulted. Check all fasteners for tightness.

Product Use, Maintenance and Servicing

Minimum Air Pressure	Maximum Air Pressure
10 PSI	100 PSI
FAILURE TO MAINTAIN CORRECT MINIMUM PRESSURE (OR PRESSURE PROPORTIONAL TO LOAD), BOTTOMING OUT, OVER-EXTENSION OR RUBBING AGAINST ANOTHER COMPONENT WILL VOID THE WARRANTY.	

MAINTENANCE GUIDELINES

NOTE

By following the steps below, vehicle owners will obtain the longest life and best results from their air springs.

1. Check the air pressure weekly.
2. Always maintain normal ride height. Never inflate beyond 100 PSI.
3. If you develop an air leak in the system, use a soapy water solution (1/5 liquid dish soap and 4/5 water) to check all air line connections and the inflation valve core before deflating and removing the air spring.

CAUTION

FOR YOUR SAFETY AND TO PREVENT POSSIBLE DAMAGE TO YOUR VEHICLE, DO NOT EXCEED MAXIMUM GROSS VEHICLE WEIGHT RATING (GVWR), AS INDICATED BY THE VEHICLE MANUFACTURER. ALTHOUGH YOUR AIR SPRINGS ARE RATED AT A MAXIMUM INFLATION PRESSURE OF 100 P.S.I., THE AIR PRESSURE ACTUALLY NEEDED IS DEPENDENT ON YOUR LOAD AND GVWR.

4. Loaded vehicles require at least 25 PSI or more. A “loaded vehicle” refers to a vehicle with a heavy bed load, a trailer, or both. As discussed above, never exceed GVWR, regardless of air spring, air pressure, or other load assist. The springs in this kit will support approximately 40 lbs. of load (combined on both springs) for each 1 PSI of pressure. The required air pressure will vary depending on the state of the original suspension. Operating the vehicle below the minimum air spring pressure will void the Air Lift warranty.
5. When increasing load, always adjust the air pressure to maintain the normal ride height. Increase or decrease pressure from the system as necessary to attain normal ride height for optimal ride and handling. Remember that loads carried behind the axle (including tongue loads) require more leveling force (pressure) than those carried directly over the axle.
6. Always add air to springs in small quantities, checking the pressure frequently.
7. Should it become necessary to raise the vehicle by the frame, make sure the system is at minimum pressure (5 PSI) to reduce the tension on the suspension/brake components. Use of on board leveling systems do not require deflation or disconnection.
8. Periodically check the air spring system fasteners for tightness. Also, check the air springs for any signs of rubbing. Realign if necessary.
9. On occasion, give the air springs a hard spray with a garden hose in order to remove mud, sand, gravel or other abrasive debris.

TROUBLESHOOTING GUIDE

1. Leak test the air line connections, the threaded connection into the air spring, and all fittings in the control system.
2. Inspect the air lines to be sure none are pinched. Tie straps may be too tight. Loosen or replace the strap and replace leaking components.
3. Inspect the air line for holes and cracks. Replace as needed.
4. Look for a kink or fold in the air line. Reroute as needed.

If the preceding steps do not solve the problem, it is possibly caused by a failed air spring — either a factory defect or an operating problem. Please call Air Lift at (800) 248-0892 for assistance.

FREQUENTLY ASKED QUESTIONS

Q. Will installing air springs increase the weight ratings of a vehicle?

No. Adding air springs will not change the weight ratings (GAWR, GCWR and/or GVWR) of a vehicle. Exceeding the GVWR is dangerous and voids the Air Lift warranty.

Q. Is it necessary to keep air in the air springs at all times and how much pressure will they need?

The minimum air pressure should be maintained at all times. The minimum air pressure keeps the air spring in shape, ensuring that it will move throughout its travel without rubbing or wearing on itself.

Q. Is it necessary to add a compressor system to the air springs?

No. Air pressure can be adjusted with any type of compressor as long as it can produce sufficient pressure to service the springs. Even a bicycle tire pump can be used, but it's a lot of work.

Q. How long should air springs last?

If the air springs are properly installed and maintained they can last indefinitely.

Q. Will raising the vehicle on a hoist for service work damage the air springs?

No. The vehicle can be lifted on a hoist for short-term service work such as tire rotation or oil changes. However, if the vehicle will be on the hoist for a prolonged period of time, support the axle with jack stands in order to take the tension off of the air springs.

TUNING THE AIR PRESSURE

Pressure determination comes down to three things — level vehicle, ride comfort, and stability.

1. Level vehicle

If the vehicle's headlights are shining into the trees or the vehicle is leaning to one side, then it is not level (fig. 13). Raise the air pressure to correct either of these problems and level the vehicle.

2. Ride comfort

If the vehicle has a rough or harsh ride it may be due to either too much pressure or not enough (fig. 14). Try different pressures to determine the best ride comfort.

3. Stability

Stability translates into safety and should be the priority, meaning the driver may need to sacrifice a perfectly level and comfortable ride. Stability issues include roll control, bounce, dive during braking and sponginess (fig. 15). Tuning out these problems usually requires an increase in pressure.



Bad headlight aim

fig. 13



Rough ride

fig. 14

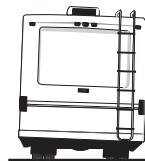

Sway and body roll

fig. 15

GUIDELINES FOR ADDING AIR

1. Start with the vehicle level or slightly above.
2. When in doubt, always add air.
3. For motorhomes, start with 50-100 PSI in the rear because it can be safely assumed that it is heavily loaded.
4. If the front of the vehicle dives while braking, increase the pressure in the front air bags, if equipped.

5. If it is ever suspected that the air bags have bottomed out, increase the pressure (fig. 16).
6. Adjust the pressure up and down to find the best ride.
7. If the vehicle rocks and rolls, adjust the air pressure to reduce movement.
8. It may be necessary to maintain different pressures on each side of the vehicle. Loads such as water, fuel, and appliances will cause the vehicle to be heavier on one side (fig. 17). As much as a 50 PSI difference is not uncommon.

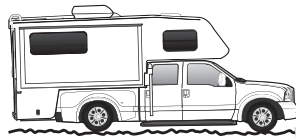

Bottoming out

fig. 16

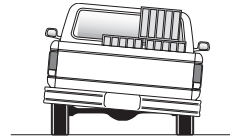

Unlevel

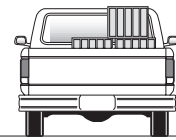

Level

fig. 17

Warranty and Returns Policy

Air Lift Company warrants its products, for the time periods listed below, to the original retail purchaser against manufacturing defects when used on catalog-listed applications on cars, vans, light trucks and motorhomes under normal operating conditions for as long as Air Lift manufactures the product. The warranty does not apply to products that have been improperly applied, improperly installed, used in racing or off-road applications, used for commercial purposes, or which have not been maintained in accordance with installation instructions furnished with all products. The consumer will be responsible for removing (labor charges) the defective product from the vehicle and returning it, transportation costs prepaid, to the dealer from which it was purchased or to Air Lift Company for verification.

Air Lift will repair or replace, at its option, defective products or components. A minimum \$10.00 shipping and handling charge will apply to all warranty claims. Before returning any defective product, you must call Air Lift at (800) 248-0892 in the U.S. and Canada (elsewhere, (517) 322-2144) for a Returned Materials Authorization (RMA) number. Returns to Air Lift can be sent to: Air Lift Company • 2727 Snow Road • Lansing, MI • 48917.

Product failures resulting from abnormal use or misuse are excluded from this warranty. The loss of use of the product, loss of time, inconvenience, commercial loss or consequential damages is not covered. The consumer is responsible for installation/reinstallation (labor charges) of the product. Air Lift Company reserves the right to change the design of any product without assuming any obligation to modify any product previously manufactured.

This warranty gives you specific legal rights and you may also have other rights that vary from state-to-state. Some states do not allow limitations on how long an implied warranty lasts or allow the exclusion or limitation of incidental or consequential damages. The above limitation or exclusion may not apply to you. There are no warranties, expressed or implied including any implied warranties of merchantability and fitness, which extend beyond this warranty period. There are no warranties that extend beyond the description on the face hereof. Seller disclaims the implied warranty of merchantability. (Dated proof of purchase required.)

Air Lift 1000	Lifetime Limited	LoadController/Dual	2 Year Limited
RideControl	Lifetime Limited	Load Controller (I)	2 Year Limited
LoadLifter 5000*	Lifetime Limited	Load Controller (II)	2 Year Limited
SlamAir	Lifetime Limited	SmartAir	2 Year Limited
AirCell	Lifetime Limited	Wireless AIR	2 Year Limited
Lifestyle & Performance**	1 Year Limited	WirelessONE	2 Year Limited
LoadController/Single	2 Year Limited	Other Accessories	2 Year Limited

*formerly SuperDuty
**formerly EasyStreet

Replacement Parts and Returns



Please do not cannibalize kits for parts!

Help us avoid waste and order by part number. If you need an air spring replacement part, please follow these steps.

Step 1 Contact your dealer and order by part number. Download a detailed list at www.airliftcompany.com/downloads.html.

Step 2 If your dealer does not have the part in stock, call Air Lift directly and we can ship you the part you need, the same day, in the U.S. or Canada.

Missing or damaged item?

Before calling Air Lift customer service, please gather the following information:

- Your receipt
- Condition the kit was in when you purchased it
- Description or part number of the missing/damaged item
- Information from the box label
 1. Kit number
 2. Weight
 3. When was the kit packed?

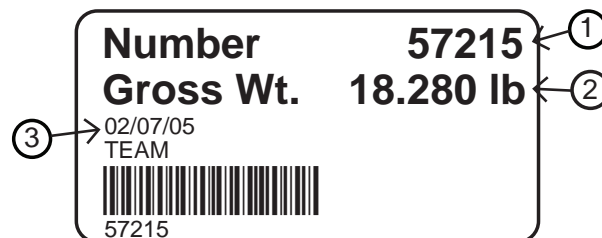

Replacement Information

If you need replacement parts, contact the local dealer or call Air Lift customer service at (800) 248-0892. Most parts are immediately available and can be shipped the same day.

Contact Air Lift Company customer service at (800) 248-0892 first if:

- Parts are missing from the kit.
- Need technical assistance on installation or operation.
- Broken or defective parts in the kit.
- Wrong parts in the kit.
- Have a warranty claim or question.

Contact the retailer where the kit was purchased:

- If it is necessary to return or exchange the kit for any reason.
- If there is a problem with shipping if shipped from the retailer.
- If there is a problem with the price.



Thank you for purchasing Air Lift products!

We're delighted to be a part of your air suspension solution. Air Lift Company is dedicated to ensuring that you have the best possible experience with our products. If you have any questions, concerns or even a suggestion, please feel free to contact us.

It's easy to put your air springs to work with an Air Lift on board air compressor system!

Air Lift offers the most advanced compressor systems in the industry. Choose the best option for your ride from many models and features!



*Four air springs require TWO compressor systems.

Choose the system best suited for your...	Analog Series		Wireless Series		Automatic Leveling
	Standard Duty	Heavy Duty	Single/Standard Duty	Dual/Heavy Duty	Automatic Leveling
<i>Pick-up with any towable</i>	25850*	25854**	25870	72000	25415
<i>Pick-up with camper</i>	25852***	25856****	N/R	72000	25430
<i>Van/SUV with leaf springs</i>	25850*	25854**	25870	72000	25415
<i>Vehicle with coil springs</i>	25850*	25854**	25870	72000	N/R
<i>Motor home</i>	N/R	25856****	N/R	72000	25430
<i>Unique applications</i>	call	call	call	call	call



Still available in panel mount style: *25592, ** 25655, ***25812, ****25651

N/R = Not Recommended

Save time and money! Register your warranty online today at www.airliftcompany.com/warrantyreg.htm

Contact Information

If you have any questions, comments or need technical assistance contact our customer service department by calling (800) 248-0892, Monday through Friday, 8 a.m. to 7 p.m. Eastern Time. For calls from outside the USA or Canada, our local number is (517) 322-2144.

For inquiries by mail, our address is PO Box 80167, Lansing, MI 48908-0167. Our shipping address for returns is 2727 Snow Road, Lansing, MI 48917.

You may also contact us anytime by e-mail at sales@airliftcompany.com or on the web at www.airliftcompany.com.

Need Help?

Contact our customer service department by calling (800) 248-0892, Monday through Friday, 8 a.m. to 7 p.m. Eastern Time. For calls from outside the USA or Canada, our local number is (517) 322-2144.

**Register your warranty online at
www.airliftcompany.com/warrantyreg.htm**



Thank you for purchasing Air Lift products — the professional installer's choice!

Air Lift Company • 2727 Snow Road • Lansing, MI 48917 or PO Box 80167 • Lansing, MI 48908-0167
Toll Free (800) 248-0892 • Local (517) 322-2144 • Fax (517) 322-0240 • www.airliftcompany.com

Printed in
the USA