

LoadLIFTER™
5000

by AIR LIFT®

Kit 57396

Ford F-250/F-350/F-450
(Single and Dual Rear Wheel)
4-Wheel Drive



INSTALLATION GUIDE

For maximum effectiveness and safety, please read these instructions completely before proceeding with installation.

Failure to read these instructions can result in an incorrect installation.



TABLE OF CONTENTS

| | |
|--|-----------|
| Introduction | 2 |
| Important Safety Notice | 2 |
| Notation Explanation | 2 |
| Installation Diagrams | 3 |
| Installation Diagram — Driver Side | 3 |
| Installation Diagram — Passenger Side | 4 |
| Hardware and Tools Lists | 5 |
| Hardware List | 5 |
| Tools List | 5 |
| Installing the LoadLifter 5000 System | 6 |
| Getting Started | 6 |
| Installing the Braces | 7 |
| Retaining Clip L-Bracket Installation on Brace | 8 |
| Driver Side Brace Installation | 9 |
| Passenger Side Brace Installation | 11 |
| Bellows and Bracket Assembly | 12 |
| Attaching the Assemblies to the Frame | 17 |
| Attaching the Lower Bracket to the Axle | 20 |
| Installing the Air Lines | 23 |
| Installing the Heat Shield | 24 |
| Checking for Leaks | 25 |
| Fixing Leaks | 25 |
| Finished Installation Photos | 26 |
| Before Operating | 27 |
| Installation Checklist | 27 |
| Post-Installation Checklist | 27 |
| Product Use, Maintenance and Servicing | 28 |
| Minimum and Maximum Pressure | 28 |
| Maintenance Guidelines | 28 |
| Troubleshooting Guide | 28 |
| Frequently Asked Questions | 29 |
| Tuning the Air Pressure | 29 |
| Guidelines for Adding Air | 30 |
| Choosing the Right On-Board Air Compressor System | 31 |
| Limited Warranty and Return Policy | 32 |
| Replacement Information | 33 |
| Contact Information | 33 |

Introduction

The purpose of this publication is to assist with the installation, maintenance and troubleshooting of the LoadLifter 5000 air spring kit. LoadLifter 5000 utilizes sturdy, reinforced, commercial grade single or double, depending on the kit, convolute bellows. The bellows are manufactured like a tire with layers of rubber and cords that control growth. LoadLifter 5000 kits are recommended for most 3/4- and 1-ton pickups and SUVs with leaf springs and provide up to 5,000 lbs. of load-leveling support with air adjustability from 5-100 PSI. The kits are used in motor home rear applications and various front applications where leaf springs are used.

It is important to read and understand the entire installation guide before beginning installation or performing any maintenance, service or repair. The information here includes a hardware list, tool list, step-by-step installation information, maintenance guidelines and operating tips.

Air Lift Company reserves the right to make changes and improvements to its products and publications at any time. For the latest version of this manual, contact Air Lift Company at (800) 248-0892 or visit airliftcompany.com.

IMPORTANT SAFETY NOTICE

The installation of this kit does not alter the Gross Vehicle Weight Rating (GVWR) or payload of the vehicle. Check your vehicle's owner's manual and do not exceed the maximum load listed for your vehicle.

Gross Vehicle Weight Rating: The maximum allowable weight of the fully loaded vehicle (including passengers and cargo). This number — along with other weight limits, as well as tire, rim size and inflation pressure data — is shown on the vehicle's Safety Compliance Certification Label.

Payload: The combined, maximum allowable weight of cargo and passengers that the truck is designed to carry. Payload is GVWR minus the Base Curb Weight.

NOTATION EXPLANATION

Hazard notations appear in various locations in this publication. Information which is highlighted by one of these notations must be observed to help minimize risk of personal injury or possible improper installation which may render the vehicle unsafe. Notes are used to help emphasize areas of procedural importance and provide helpful suggestions. The following definitions explain the use of these notations as they appear throughout this guide.



DANGER

INDICATES IMMEDIATE HAZARDS WHICH WILL RESULT IN SEVERE PERSONAL INJURY OR DEATH.



WARNING

INDICATES HAZARDS OR UNSAFE PRACTICES WHICH COULD RESULT IN SEVERE PERSONAL INJURY OR DEATH.



CAUTION

INDICATES HAZARDS OR UNSAFE PRACTICES WHICH COULD RESULT IN DAMAGE TO THE MACHINE OR MINOR PERSONAL INJURY.

NOTE

Indicates a procedure, practice or hint which is important to highlight.

Installation Diagram - Driver Side

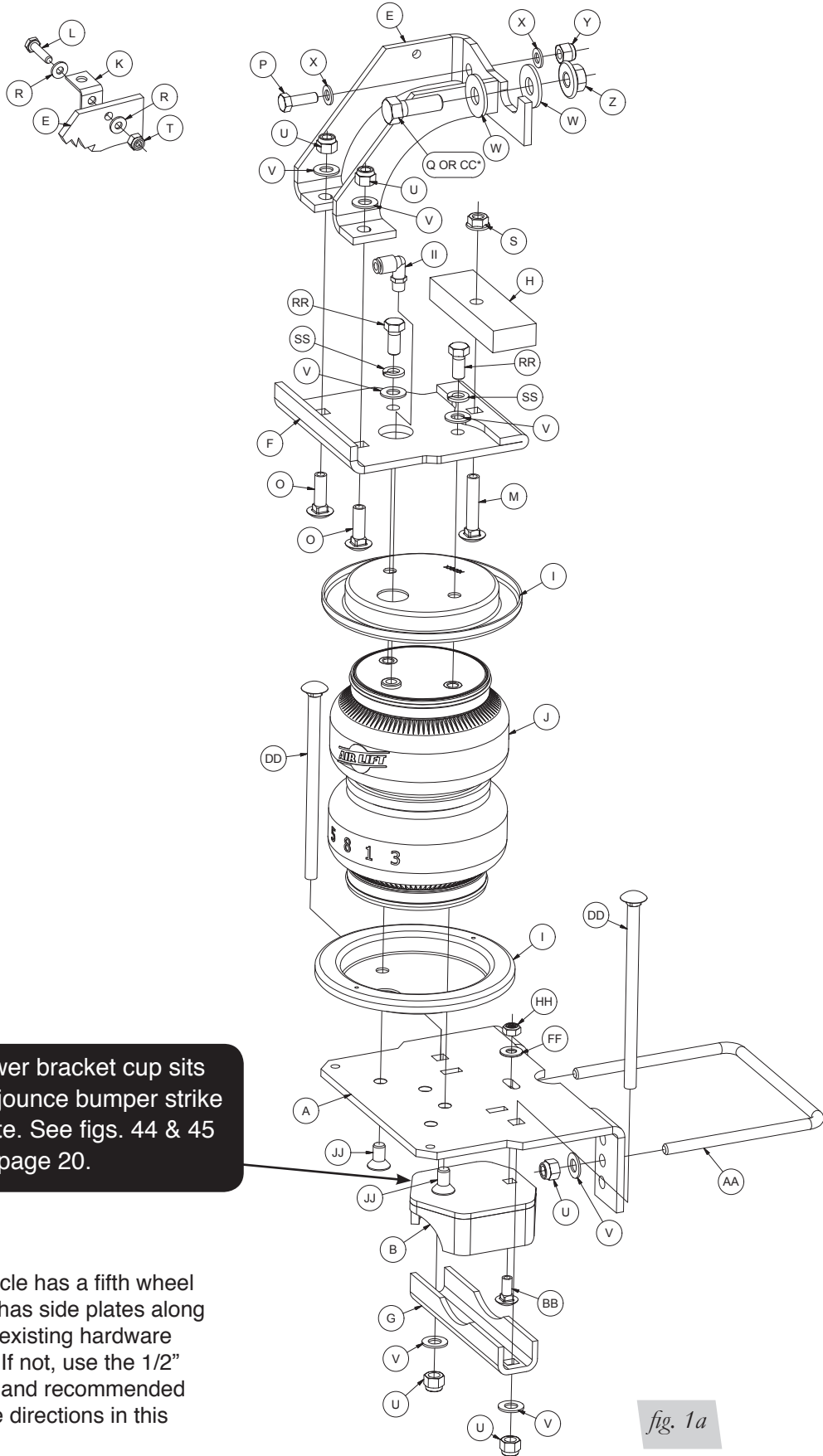

A Lower bracket cup sits on jounce bumper strike plate. See figs. 44 & 45 on page 20.

*** NOTE:** If the vehicle has a fifth wheel hitch installed that has side plates along the frame, use the existing hardware that was removed. If not, use the 1/2" hardware supplied and recommended in this kit and in the directions in this manual.

fig. 1a

Installation Diagram - Passenger Side

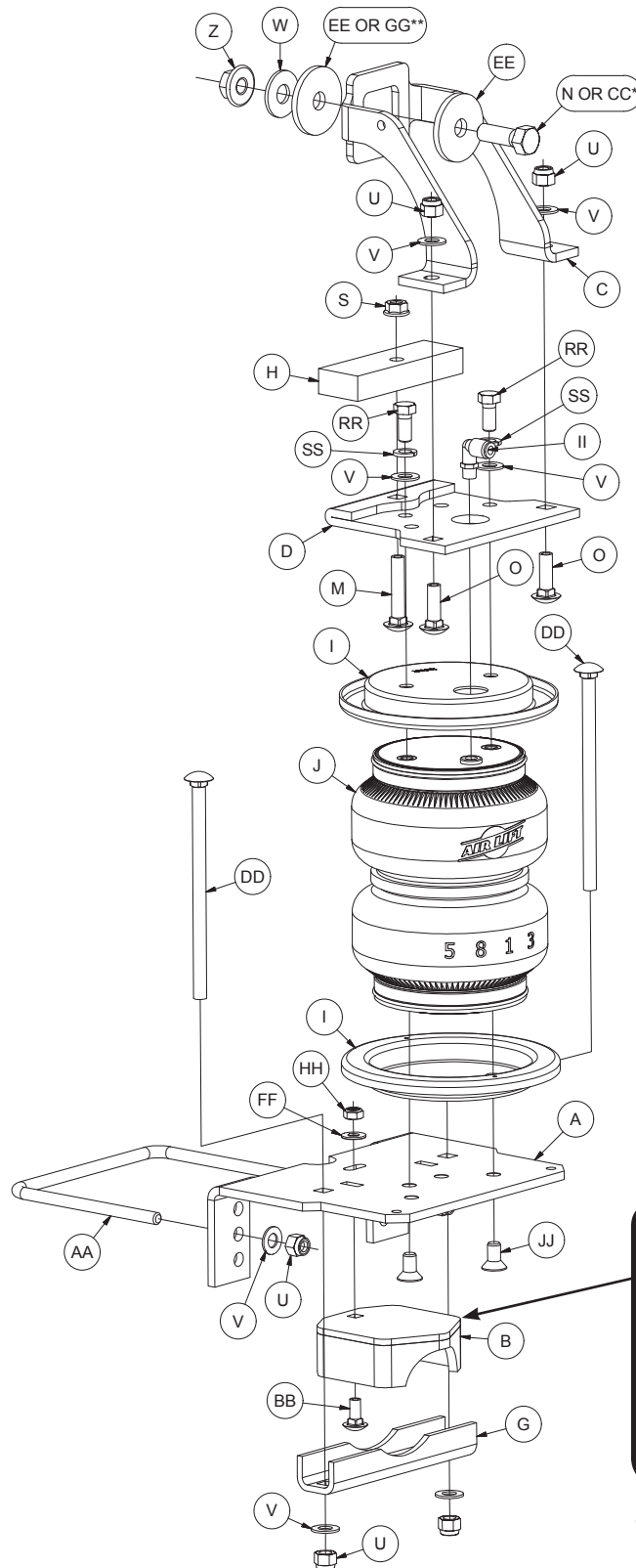

*** NOTE:** If the vehicle has a fifth wheel hitch installed that has side plates along the frame, use the existing hardware that was removed. If not, use the 1/2" hardware supplied and recommended in this kit and in the directions in this manual.

**** NOTE:** Use 3/4" flat washer (GG) if using 3/4" fifth wheel hitch hardware removed.

A Lower bracket cup sits on jounce bumper strike plate. See figs. 44 & 45 on page 20.

fig. 1b

Hardware and Tools Lists

HARDWARE LIST

| Item | Part # | Description..... | QTY |
|------|--------|---------------------------------------|-----|
| A | 03997 | Lower Bracket Main Plate | 2 |
| B | 03998 | Lower Bracket Cup..... | 2 |
| C | 07996 | Upper Brace, RH..... | 1 |
| D | 07997 | Upper Bracket, RH..... | 1 |
| E | 07994 | Upper Brace, LH..... | 1 |
| F | 07995 | Upper Bracket, LH..... | 1 |
| G | 01531 | Clamp Bar | 2 |
| H | 13966 | Spacer | 2 |
| I | 11951 | Roll Plates | 4 |
| J | 58437 | Bellows | 2 |
| K | 10886 | L Bracket | 1 |
| L | 17135 | 1/4"-20 X 1" Hex Cap Screw | 1 |
| M | 17140 | 3/8"-16 X 2" Carriage Bolt | 2 |
| N | 17161 | 1/2"-13 X 1.5" Hex Cap Screw | 1 |
| O | 17361 | 3/8"-16 X 1.25" Carriage Bolt | 4 |
| P | 17177 | 8mm-1.25 X 25mm Hex Cap Screw..... | 1 |
| Q | 17412 | 1/2"-13 X 1.25" Hex Cap Screw | 1 |
| R | 18419 | #12 Flat Washer | 2 |
| S | 18422 | 3/8"-16 Serrated Flange Locknut..... | 2 |
| T | 18425 | 1/4"-20 Nylon Locknut | 1 |
| U | 18435 | 3/8"-16 Nylon Locknut | 12 |
| V | 18444 | 3/8" Flat Washer..... | 16 |
| W | 18485 | 1/2" Flat Washer..... | 3 |
| X | 18501 | M8 Flat Washer..... | 2 |
| Y | 18522 | M8 X 1.25 Nylon Locknut | 1 |
| Z | 18505 | 1/2"-13 Serrated Flange Lock Nut..... | 2 |
| AA | 11717 | U-Bolt | 2 |
| BB | 17500 | 5/16"-18 X 3/4" Carriage Bolt | 2 |
| CC | 17271 | 1/2"-13 X 3" Hex Cap Screw | 2 |
| DD | 17387 | 3/8"-16 X 10" Carriage Bolt | 4 |
| EE | 18207 | 1/2", Thick Flat Washer | 2 |
| FF | 18433 | 5/16" Flat Washer..... | 2 |
| GG | 18556 | 3/4" Flat Washer..... | 1 |
| HH | 18613 | 5/16"-18 Nylon Locknut | 2 |
| II | 21837 | 90° Swivel Elbow..... | 2 |
| JJ | 17215 | 3/8"-24 X 3/4" Flat Head Screw..... | 4 |
| KK | 20086 | Air Line | 1 |
| LL | 10466 | Tie Straps | 6 |
| MM | 21230 | Valve Cap..... | 2 |
| NN | 18501 | 5/16" Flat Washer..... | 2 |
| OO | 21234 | Rubber Washer | 2 |
| PP | 18411 | Star Washer | 2 |
| QQ | 21233 | 5/16" Hex Nut | 4 |
| RR | 17203 | 3/8"-24 X 7/8" Hex Cap Screw | 4 |
| SS | 18427 | 3/8" Lock Washer | 4 |

TOOLS LIST

| Description..... | Qty |
|--|-----|
| Metric & STD Open-Box End Wrenches | set |
| Ratchet with Metric and STD Sockets | set |
| Drill and 5/16" Drill Bit..... | 1 |
| Torque Wrench..... | 1 |
| Hose Cutter, Razor Blade or Sharp Knife..... | 1 |
| Hoist or Floor Jack..... | 1 |
| Safety Stands | 2 |
| Safety Glasses | 1 |
| Air Compressor or Compressed Air Source | 1 |
| Spray Bottle with Dish Soap/Water Solution | 1 |



Missing or damaged parts? Call Air Lift customer service at (800) 248-0892 for a replacement part.

Installing the LoadLifter 5000 System

GETTING STARTED

1. Raise the vehicle and support it in a way, using jack stands or equivalent, that the axle can be safely dropped away from the frame. This will need to be done in order for the air spring assembly to be put into position between the axle and frame (Figs. 1a, 1b and 2). Figure 2 shows the frame being supported with the vehicle on a drive-on hoist.



fig. 2

2. Remove the jounce bumpers from under the frame, over the axle (Figs. 3 and 4).

NOTE

Wire brush the stud on the jounce bumper and use some penetrating oil to help in removal of the jounce bumper. Usually the socket size for the nut is a 15 mm.

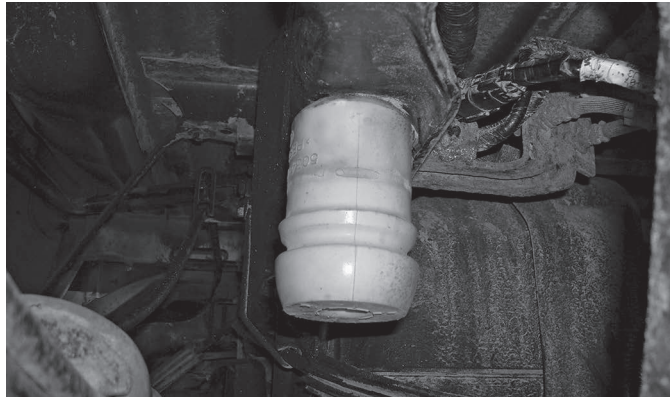
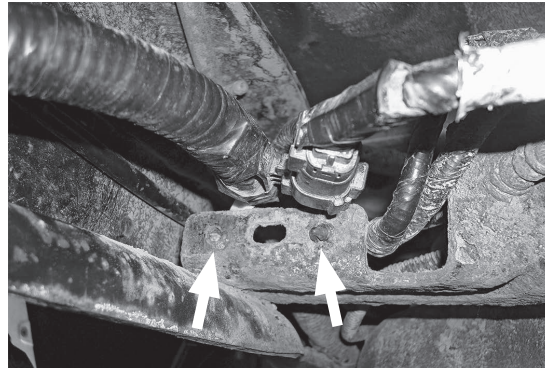

fig. 3



fig. 4

3. If necessary, disconnect the wiring harness from the driver's side frame rail to gain clearance for the upper brace (Fig. 5). Also, push out the harness connector that holds the electrical lines going to the gas/urea tank in or out of the tank bracket. This will improve socket/bolt access that will be required for installing and tightening the frame brace (Fig. 6).



Remove the line holders from the gas/urea tank bracket for easier access to the upper brace hardware.

fig. 5

4. If the truck has a fifth wheel hitch already installed, **other than the standard factory Reese hitch** purchased with the truck, it will be necessary to remove the hardware that bolts the side bracket (plates) to the outside of the frame above the axle.

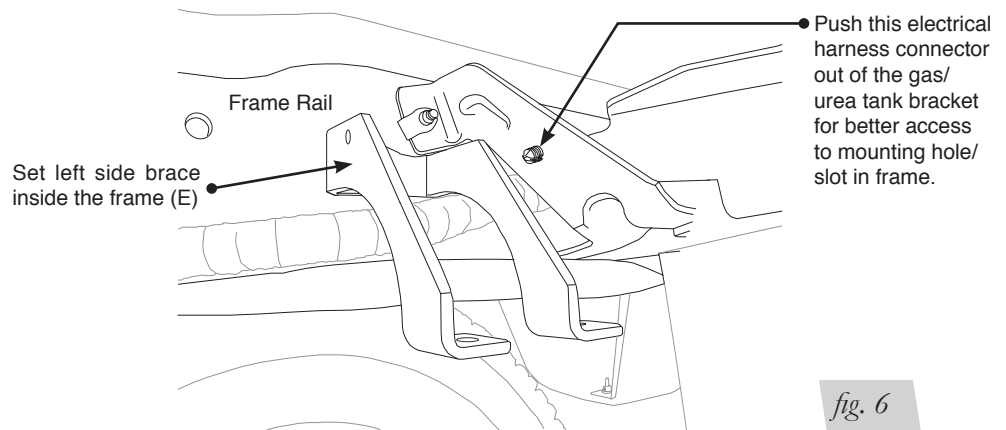
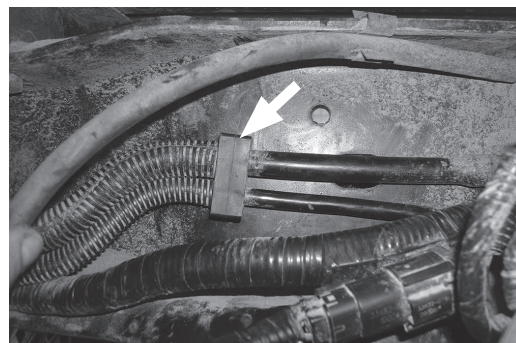

fig. 6

INSTALLING THE BRACES

Gas engine models have emission lines on the inside of the frame. If the truck has emission lines running along the inside of the frame rail (Fig. 7), it will be necessary to relocate those lines as follows:

1. Carefully push the line holder out of the frame above the axle. Try to minimize damage because it will be reused later. It may also be helpful to remove any emissions/fuel line retaining clips forward or rearward of the axle to aid in positioning the lines once the upper brace has been installed (Figs. 7 and 8). The same holds true for the electrical wire loom retaining clips.



If equipped, this emissions/fuel line retaining clip must be pulled away from the frame in order to install the upper frame brace (E).

fig. 7

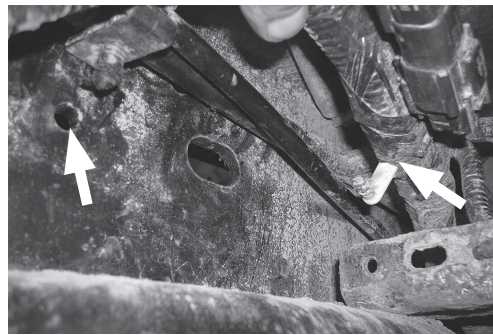
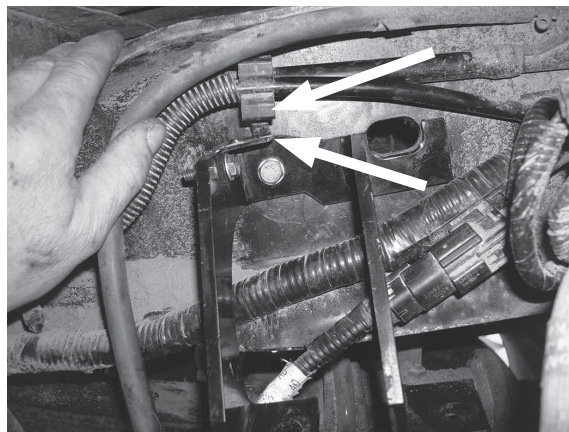

Image shows lines clear on the frame opening it up for the brace installation.

fig. 8

RETAINING CLIP L-BRACKET INSTALLATION ON BRACE

1. In order to re-attach the previously removed emissions line, it will be necessary to attach the provided L-bracket (K) to the back frame brace using the 1/4"-20 x 1" bolt (L), flat washers #12 (R) and 1/4"-20 nylon lock nut (T) supplied (fig. 6). Placing this L-bracket depends on where the line holder is on the wiring or the emissions line that was previously pulled from the frame. Set the driver's side frame brace (E) up into the frame and insert the 8mm-1.25 x 25mm hex cap screw (P) with an 8mm flat washer (X) through the brace and into the hole in the side of the frame from which the line holder was removed (Fig. 9). This will hold the line in place. Note what side the line holder is in, in respect to the back leg of the brace. Is it forward or behind the back leg of the brace? Where the line holder lines up is the side where the L-bracket is to be installed (Figs. 6 and 9).



Brace being temporarily held in place by the 8mm bolt and washer. L-bracket is shown in location already. Note: The side the line holder is on depends on the location of the factory retaining clip.

fig. 9

2. Pull the brace back out and attach the L-bracket onto the brace with the hardware noted above, in the proper location previously found (Figs. 10 and 11). Make sure the L-bracket faces up and tighten securely.

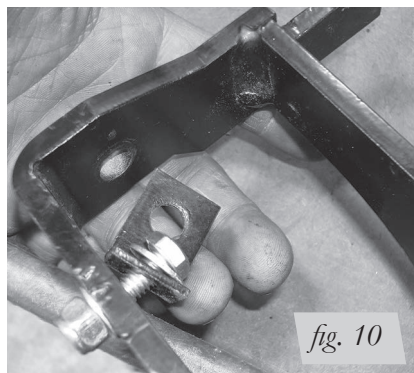

fig. 10

Attach the L-bracket to the brace in the position previously found using the hardware specified.

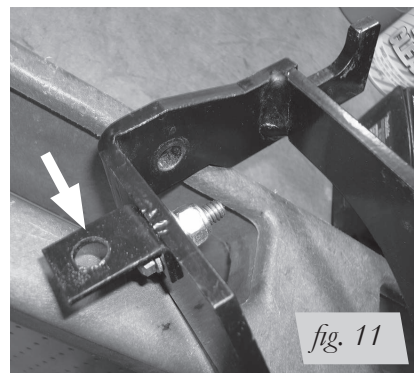

fig. 11

No matter what side the L-bracket is on, make sure it is installed so the flat side points up when tightening.

DRIVER'S SIDE BRACE INSTALLATION

1. Set the left upper brace (E) into the driver's side frame rail. The brace has a small hole that will line up with an existing hole in the frame. Insert the 8mm-1.25 x 25mm hex cap screw (P) with an 8mm flat washer (X) through the brace and frame (Figs. 12 and 13) and cap with 8mm flat washer (X) and 8mm x 1.25 nylon lock nut (Y). Leave loose at this time.

CAUTION

BE SURE NOT TO PINCH THE PREVIOUSLY MOVED WIRING OR LINES INSIDE THE LEFT FRAME RAIL.

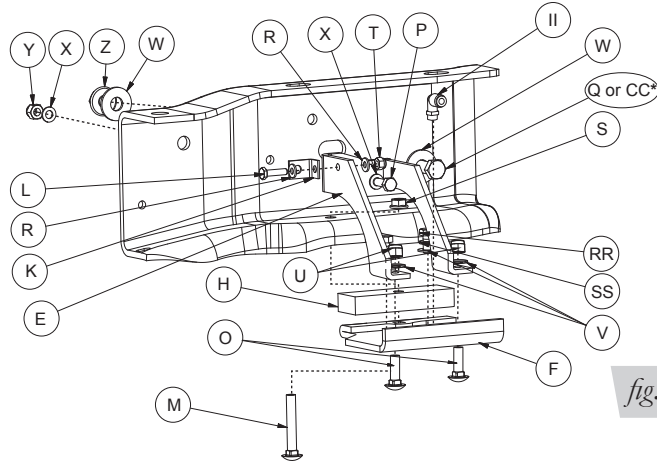
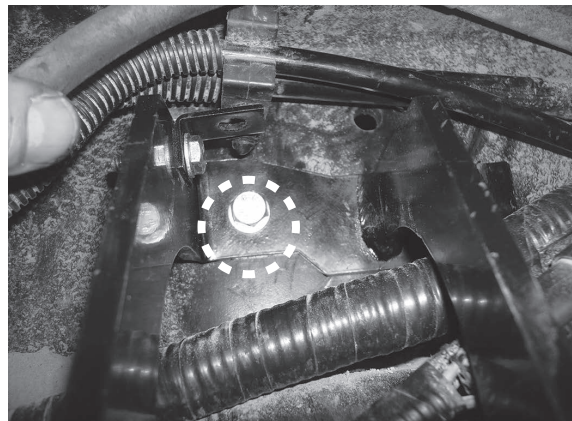

fig. 12



Attach the bracket to the frame using the 8mm hardware noted.

fig. 13

2. If the truck has no fifth wheel hitch or if it has the **standard equipment Reese fifth wheel hitch** that was purchased on the truck from Ford, in the frame there is a slot that is forward of the 8mm bolt just installed, insert the 1/2"-13 x 1.25" hex cap screw (Q) and 1/2" flat washer (W) through the brace and frame (from the inside out). Cap with a 1/2" flat washer (W) and a 1/2"-13 serrated flange lock nut (Z) (Figs. 12, 14 and 15). Do not tighten at this time.

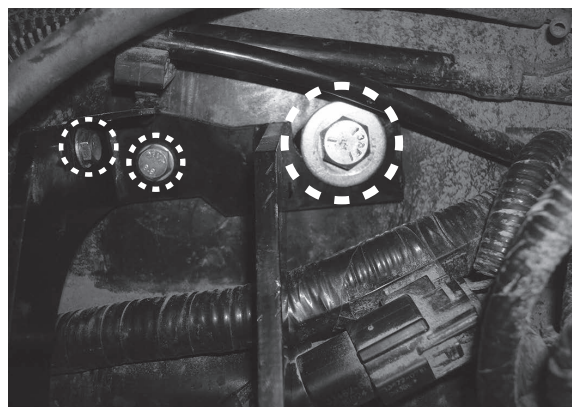

Driver's side brace shown with supplied hardware in place. Existing fifth wheel hardware which may have been removed may look different.

fig. 14

If the truck has an aftermarket fifth wheel hitch that has an outer bracket (plate) running along side of the frame and it used this slot to secure the bracket with existing hardware, install the original fifth wheel hardware previously removed in the “getting started section” from the fifth wheel installation for securing the brace (Fig. 12). Do not tighten at this time.

OR

If the truck has an aftermarket fifth wheel hitch that has an outer bracket (plate) running along side of the frame and it **does not have** any attaching hardware on the side where the slot in the frame is, it will be necessary to drill a 1/2” hole through the plate using the slot in the frame as a template. Drill the hole as far to the rear of the slot as possible.

CAUTION

CLEAR ANY ELECTRICAL OR HARD LINES FROM THE AREA SO AS NOT TO DAMAGE THEM IN ANY WAY WHEN DRILLING THE HOLE.

NOTE

It may be necessary to mark and remove the outer bracket (plate) from the side of the frame in order to drill the hole correctly. Re-attach once the hole is drilled.

Insert a 1/2”-13 x 3” hex cap screw (CC) with a 1/2” flat washer (W) through the brace, frame and fifth wheel plate previously drilled. Cap with a 1/2” flat washer (W) and a 1/2”-13 serrated flange lock nut (Z) (Fig. 15). Leave loose at this time.

Rear view of driver's (left) side shown

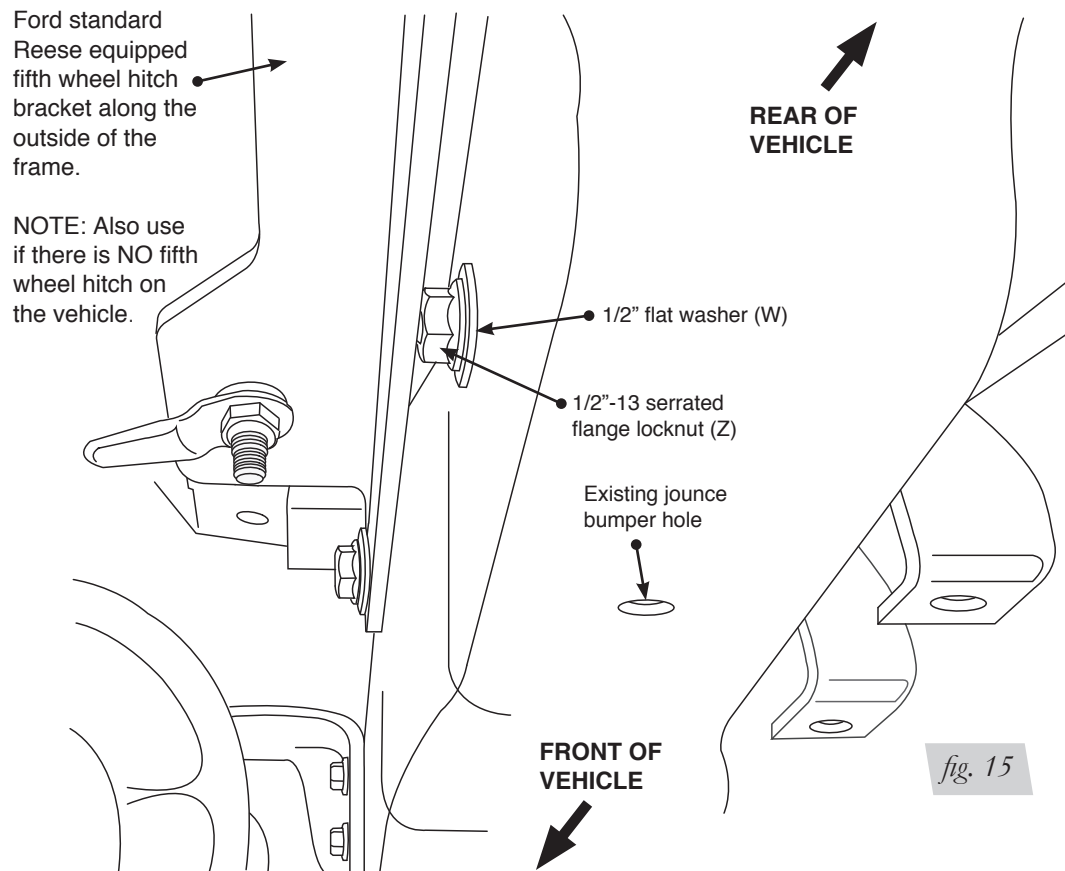

PASSENGER SIDE BRACE INSTALLATION

1. Set the right upper brace (C) into the passenger side frame rail (Figs. 16, 17 and 18).

Inside view of passenger's (right) side frame shown

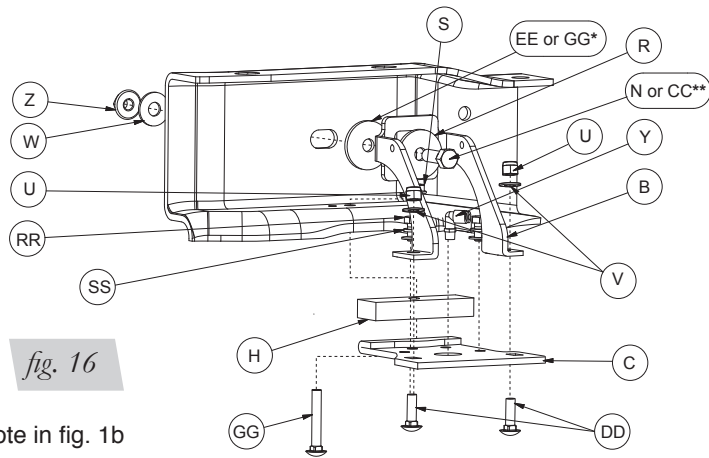
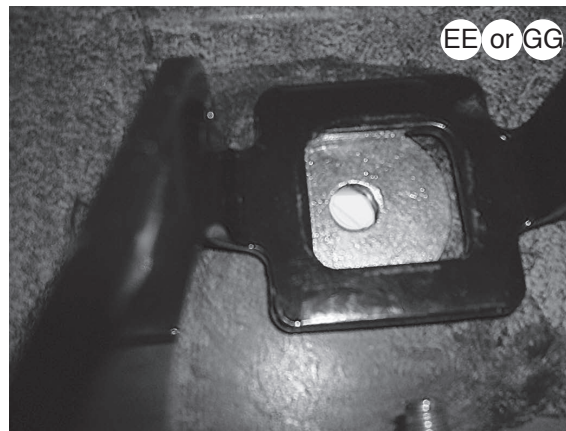

fig. 16

- * See footnote in fig. 1b
- ** See footnote in fig. 1b

← FRONT OF VEHICLE

REAR OF VEHICLE →



For the passenger side, before inserting the upper brace hardware, make sure that the 1/2" thick washer (EE) or (GG) is installed in between the brace and frame (see Step 2). Note: The 1/2" thick washer (EE) is not a half inch thick. It has a 1/2" hole and is a thick washer.

fig. 17

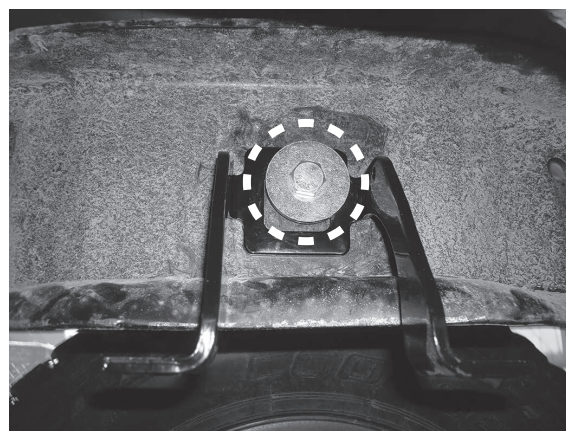

Passenger side upper brace shown with hardware supplied in place.

fig. 18

- For trucks with **no fifth wheel or the OEM purchased Reese fifth wheel hitch**, insert the 1/2"-13 x 1.50" hex cap screw (N) and 1/2" thick flat washer (EE) through the brace, between the brace and the frame add the 1/2" thick flat washer (EE) then through the frame (from the inside out). **Note:** The 1/2" thick flat washer (EE) is not a half inch thick. It has a 1/2" hole and is a thick washer. Cap with a 1/2" flat washer (W) and a 1/2"-13 serrated flange lock nut (Z) (Figs. 15 and 16). Do not tighten at this time.

OR

If the truck has an aftermarket fifth wheel hitch that has an outer bracket (plate) running along side of the frame and it used this slot to secure the bracket to the frame with existing hardware, re-install the original hardware previously removed in the "Getting Started" section. However, add the 1/2" thick flat washer (EE) or 3/4" flat washer (GG) depending on whether the existing hardware is in between the brace and the frame (Fig. 16).

NOTE

The 1/2" thick flat washer (EE) is not a half inch thick. It has a 1/2" hole and is a thick washer. Do not tighten at this time.

OR

If the truck has an aftermarket fifth wheel hitch that has a bracket (plate) running along side of the frame and it **does not have** any attaching hardware on the side where the slot in the frame is, it will be necessary to drill a 1/2" hole through the plate using the slot in the frame as a template.

NOTE

It may be necessary to mark and remove the bracket (plate) from the side of the frame in order to drill the hole correctly. Re-attach once the hole is drilled.

Insert a 1/2"-13 x 3" hex cap screw (CC) with a 1/2" thick flat washer (EE) through the brace, between the brace and the frame add the 1/2" thick flat washer (EE) then through the frame and fifth wheel plate previously drilled. **NOTE:** The 1/2" thick fat washer (EE) is not a half inch thick. It has a 1/2" hole and is a thick washer. Cap with a 1/2" flat washer (W) and a 1/2"-13 serrated flange lock nut (Z) (Fig. 15). Leave loose at this time.

BELLOWS AND BRACKET ASSEMBLY

- Set roll plates (I) over the top and bottom of the bellows (J) (Figs. 1a, 1b and 19).

NOTE

The radiused (rounded) edge of the roll plate (I) will be toward the bellows so that the bellows is seated inside both roll plates.

- Install the swivel elbow fitting (II) into the top of the bellows finger tight. Tighten the swivel fitting one and a half turns.



Set roll plate (I) over the bellows and install the fitting (II) as stated. Repeat for both bellows.

fig. 19

3. Insert a 5/16"-18 X 3/4" carriage bolt (BB) through the square hole in the lower bracket cup (B). Make sure to insert the carriage bolt on the flanged side of the bracket. Set the assembly onto the lower bracket main plate (A) making sure the lower bracket cup (B) is on the flanged side of the bracket (Fig. 20).

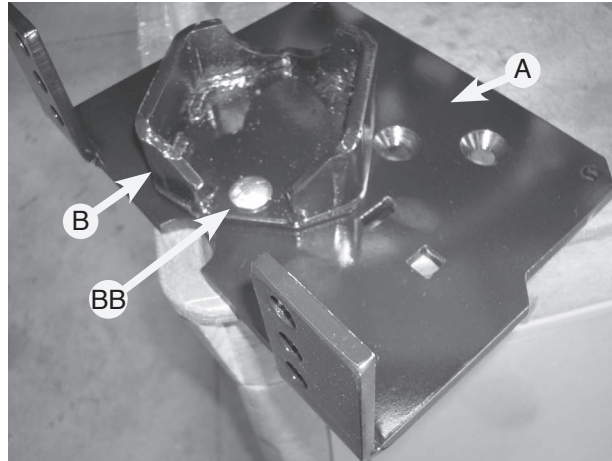

fig. 20

4. Flip the assembly over and cap the 5/16" carriage bolt with a 5/16" flat washer (FF) and 5/16" nylon nut (HH) (Figs. 21 and 22). Tighten the nut only tight enough so that the cup still swivels on the lower bracket main plate (Fig. 23).



fig. 21

Top of lower bracket.

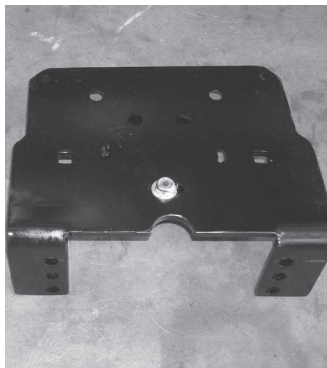

fig. 22

Bottom of lower bracket.

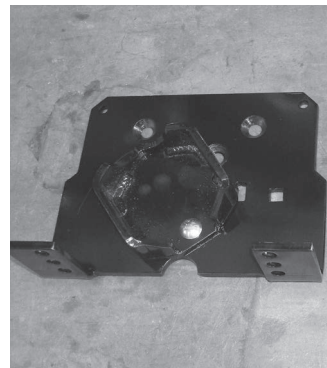

fig. 23

5. Insert one of the 3/8"-16 X 10" carriage bolts (DD) into the lower bracket assembly previously assembled (Fig. 24). Determine which holes correspond with either side (Fig. 25).

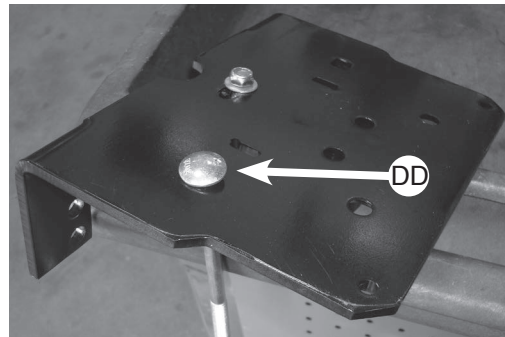

fig. 24

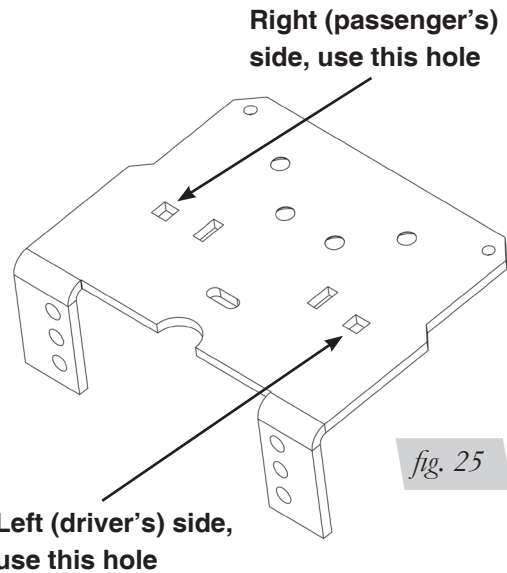

fig. 25

NOTE

The 3/8"-16 X 10" carriage bolts will be behind the axle once the assembly is installed on the axle.

6. The lower bracket assembly has two sets of bellows mounting holes, one for the driver's side, the other for the passenger's. Using the corresponding holes in the lower bracket designated (Figs. 26 and 27), attach the bellows to the bracket using the 3/8"-24 flat head screws (JJ) and torque to no more than 20 lb.-ft.

7. Fig. 28 shows the driver's side and passenger's side assemblies.

This slot should be on the opposite side of the air line fitting on the bellows once mounted.

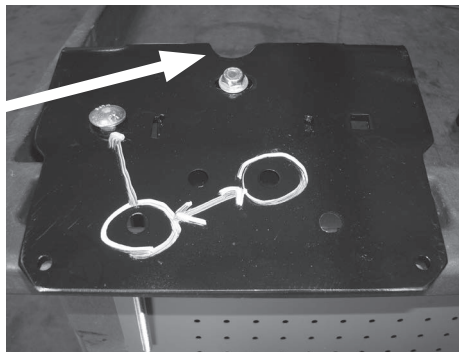

fig. 26

Driver's side bellows mounting holes shown in location to the 3/8"-16 x 10" carriage bolt previously installed. When installing on the bellows, make sure the bracket edge facing you is on the fitting side of the bellows.

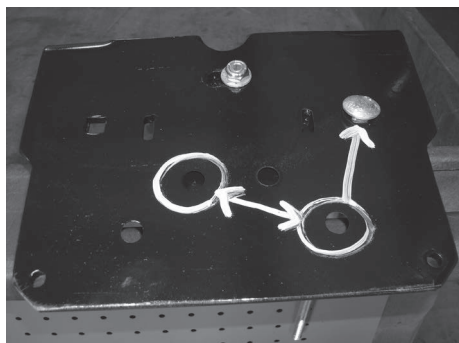
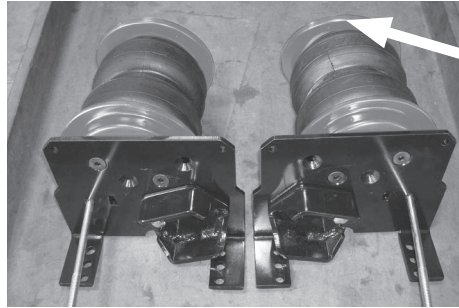

fig. 27

Passenger's side bellows mounting holes shown in location to the 3/8"-16 x 10" carriage bolt previously installed. When installing on the bellows, make sure the bracket edge facing you is on the fitting side of the bellows.

Driver's Side



Passenger's Side

The bellows fitting must be on this side of the assembly.

fig. 28

NOTE

The 3/8"-16 X 10" carriage bolts will be behind the axle once the assembly is installed on the axle.

- Set the lower bracket assembly aside. Pick up the driver side (F) and passenger side (D) upper brackets (Figs. 29 and 30). Insert two 3/8"-16 X 1.25" carriage bolts (O) up through the bottom of the driver side (F) and passenger side (D) upper brackets (Figs. 29 and 30), through the two square holes that are on the corresponding side. Also, insert one 3/8"-16 X 2" carriage bolt (M) through the remaining hole. The head of this carriage bolt will be hidden once the upper bracket is mounted to the bellows.

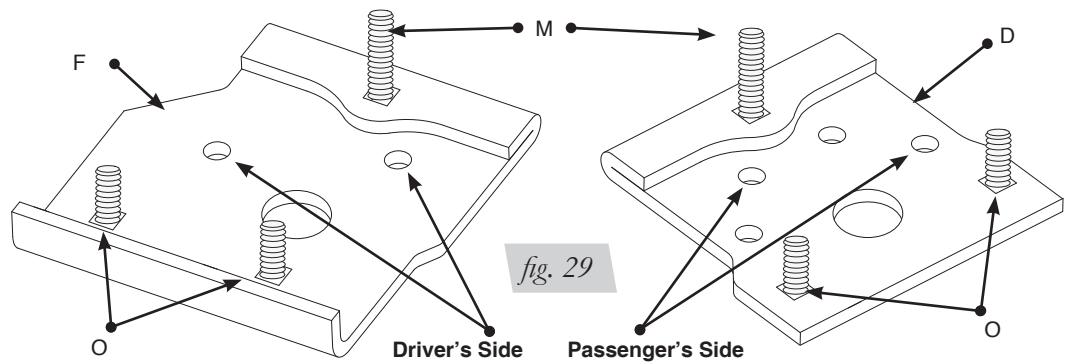

fig. 29

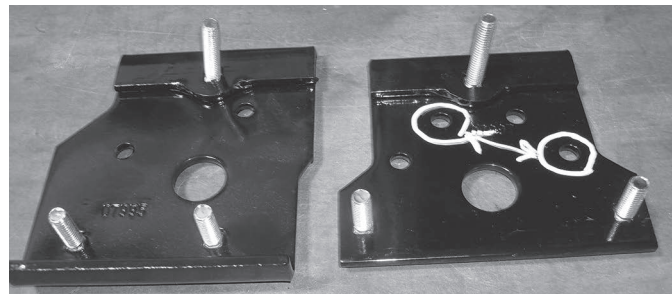

fig. 30

Driver's Side

Passenger's Side

NOTE

One of the 3/8"-16 X 1.25" carriage bolts (O) will not be covered by the roll plate and may fall out. If so, retain for use in the "Attaching the assemblies to the frame" section later in this manual.

- Set the driver's side (left) upper bracket onto the driver's side bellows assembly previously assembled, using the holes in the upper bracket designated (Fig. 29), and attach to the bellows with two 3/8" flat washers (V), 3/8" lock washers (SS) and 3/8"-24 X 7/8" hex cap screws (RR). Torque no more than 20 lb.-ft. (Figs. 31, 32 and 33).

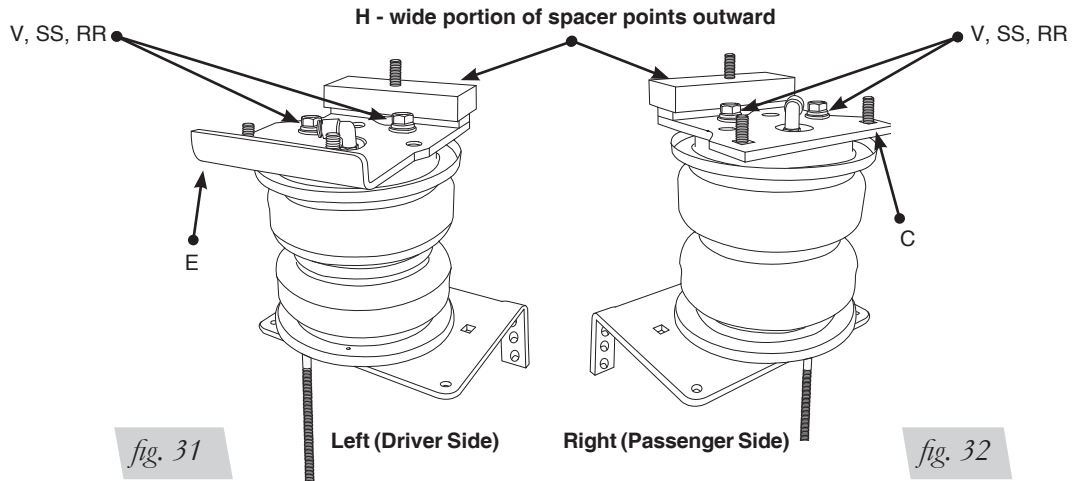
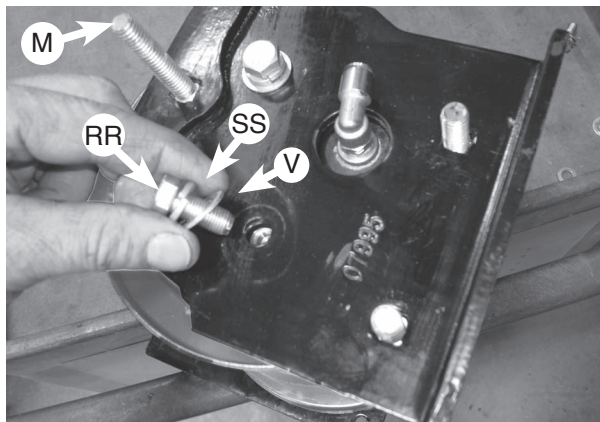

fig. 31

fig. 32



Attach the upper bracket to the bellows assembly with two 3/8" flat washers (V), 3/8" lock washers (SS), and 3/8"-24 x 7/8" hex head cap screws (RR).

fig. 33

- Repeat the above process on the passenger side assembly (Fig. 32).
- Set the spacers (H) over both 3/8"-16 X 2" carriage bolts (M) (Figs. 31, 32 and 34).

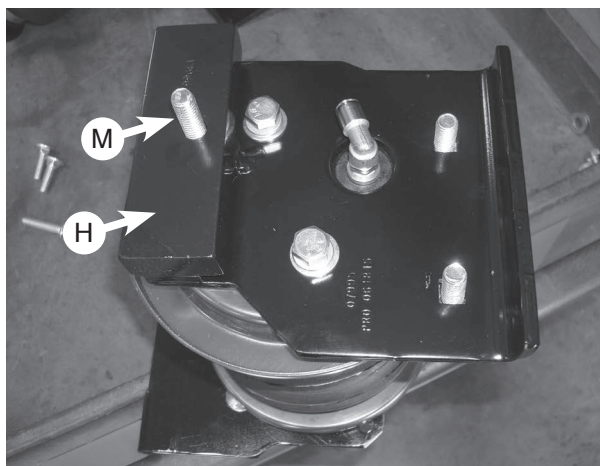

Spacer (H) set on bracket in position. The wide side of the spacer faces the outside of the vehicle.

fig. 34

NOTE

The hole in the flat spacer (H) is offset. Install the spacer so that the wide portion faces the outside of the vehicle (Figs. 31 and 32).

12. Figure 35 shows the assemblies complete and ready to install.

Driver's side assembly

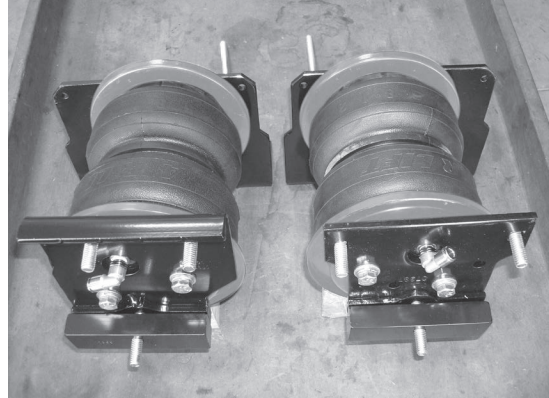

Passenger's side assembly

fig. 35

ATTACHING THE ASSEMBLIES TO THE FRAME

1. Drop the axle or raise the frame to make room to put the assemblies into position.
2. Set the left (driver's side) assembly onto the jounce bumper strike plate (Fig. 36). Make sure the 3/8"-16 X 10" carriage bolt (DD) on the bottom bracket goes in between the hard brake line and axle on the back side of the axle. Raise the axle just enough to insert the 3/8"-16 X 2" carriage bolt (M) (that is installed in the upper bracket) through the existing jounce bumper hole in the bottom of the frame. At the same time, line up the upper brace into the remaining two carriage bolts in the assembly's upper bracket (Fig. 37). Do this just enough for the carriage bolts to hold the assembly into position in the frame, while resting on the jounce bumper strike plate (Fig. 36).

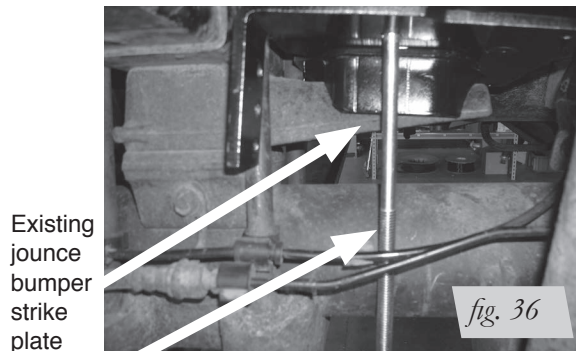

Existing jounce bumper strike plate

The long carriage bolt must go in between the axle and the hard brake/ABS line on the driver's side.

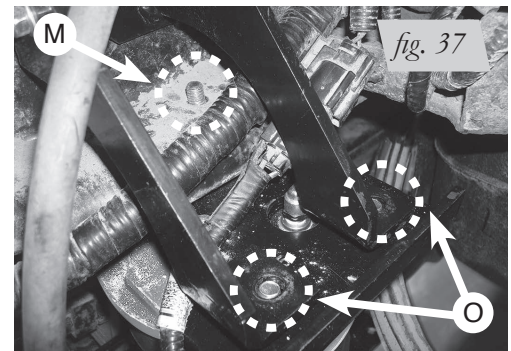

Raise the axle up while aligning the 3/8"-16 x 2" carriage bolt through the frame and the two 3/8"-16 X 1.25" carriage bolts in the upper bracket, through the brace.

3. Set the right (passenger side) assembly into position on the jounce bumper strike plate the same way the left side was positioned (Fig. 38). Note that the long carriage bolt goes outside of the hard brake line on the passenger side.

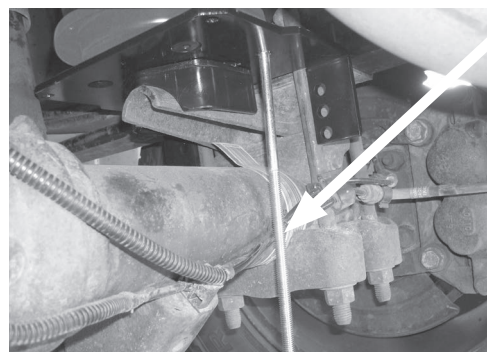

The long carriage bolt goes on the outside (backside) of the hard brake/ABS line on the passenger side.

fig. 38

4. Make sure the thick spacer (H) is parallel to the frame and bracket (Fig. 39). Finish raising the axle or lowering the frame until the spacer contacts the frame on both sides.

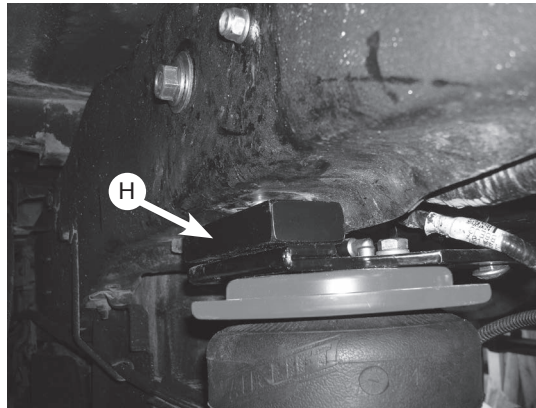

Make sure the spacer (H) is parallel to both the frame and upper bracket. Raise axle or lower frame until the spacer touches the frame on both sides.

fig. 39

5. Install the 3/8"-16 serrated flange locknut (S) on the 3/8"-16 X 2" carriage bolt (M) that went through the existing jounce bumper hole and tighten securely on both sides (Fig. 40).

CAUTION

BE SURE NOT TO PINCH THE PREVIOUSLY MOVED WIRING OR LINES INSIDE THE LEFT FRAME RAIL.

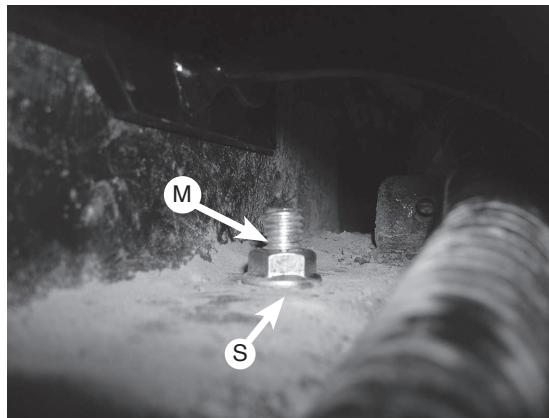

Install the 3/8"-16 serrated flange locknut (S) onto the 3/8"-16 x 2" carriage bolt (M) that goes through the flange on the frame and tighten.

fig. 40

6. Cap the 3/8"-16 X 1.25" carriage bolts (O) with a 3/8" flat washers (V) and 3/8" nylon lock nut (U) on both sides and torque to 15 lb.-ft.. (Fig. 41).

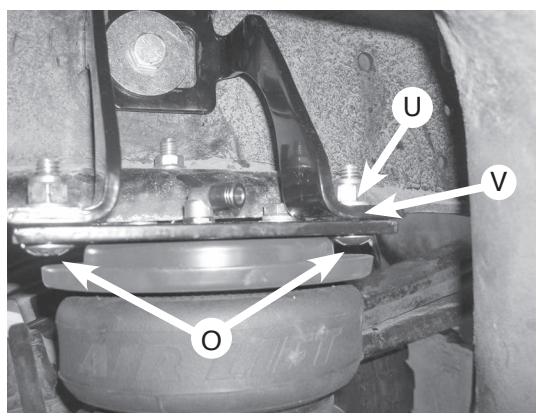

Cap the 3/8"-16 x 1.25" carriage bolts with 3/8" nylon lock nuts and torque to 15 lb.-ft.. Repeat for both sides.

fig. 41

7. With the spacers (H) on the upper brackets tight to the bottom of the frame and the braces tight to the upper brackets, tighten the 8mm (driver's side only) and 1/2" or 3/4" hardware previously installed, that hold the braces to the frame (Fig. 42). Tighten both sides.

NOTE

If possible, use a thin socket. It helps to pull back the driver side, mounting hardware (Q or CC) as far back in the slot as possible while tightening.

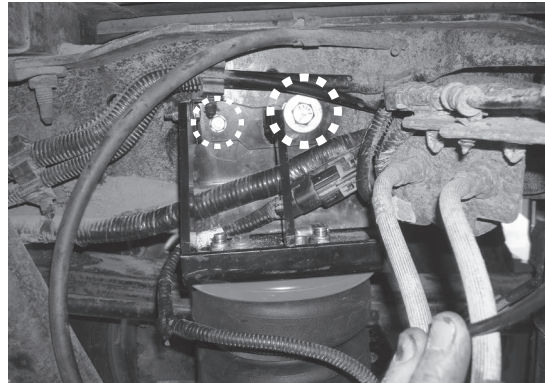

Tighten the 8 mm hardware and the **1/2" (or 3/4"** if from the 5th wheel hitch hardware) and tighten securely. Repeat for the hardware on the opposite side.

fig. 42

8. Once the left (driver's side) 1/2" or 3/4" hardware has been tightened, push the wiring harness connector – which was removed in the "getting started section" – back into the gas/urea tank mounting hole. If the connector broke during disassembly, wire tie it to the bracket (Figs. 5 and 6).

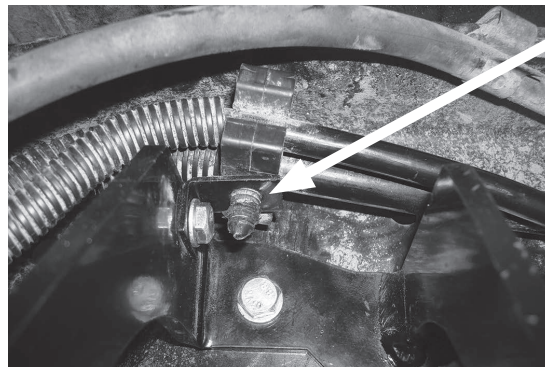

Insert the line holder previously removed into the L-bracket installed on the upper brace as shown.

fig. 43

9. If equipped with the emissions line previously loosened from the frame, insert the line holder post into the L-bracket (K) attached to the back leg of the upper left brace (E) (Fig. 43). It may be necessary to move the line holder post forward or back on the lines to line up correctly with the L-bracket hole. Reattach any line holders removed forward or behind the axle, if possible, that were removed to aid in positioning the upper bracket.

ATTACHING THE LOWER BRACKET TO THE AXLE

1. Push the lower bracket up against the stock U-bolts so that the legs of the lower bracket are locked into position around the stock U-bolts (Fig. 44). It may be necessary to rotate the lower bracket on the jounce bumper strike plate in order to do this.

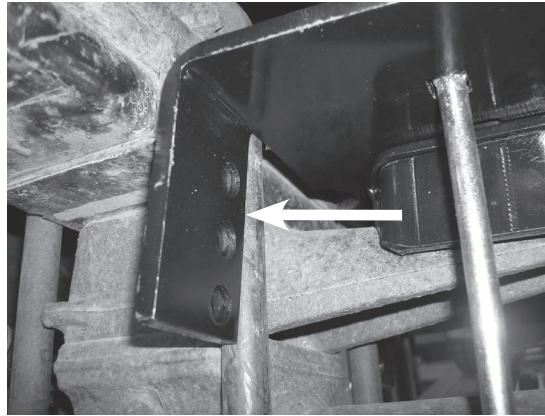

Rotate the lower bracket on the spring perch if necessary and push the bracket up against the U-bolts to put the lower bracket into position.

fig. 44

2. Make sure the cup on the bottom of the lower bracket is nested onto the jounce bumper strike plate and the flanges of the cup are touching the strike plate on both the front and back side (Fig. 45). If it does not sit on the jounce bumper strike plate correctly, the cup swivels on the main plate. Rotate or move the cup to obtain this condition.



Make sure the cup is seated onto the jounce bumper strike plate forward and behind the axle.

fig. 45

3. Position U-bolt (AA) around the leaf spring assembly and insert in the hole closest to the leaf spring stack (Fig. 46). The lower bracket flanges must be locked on the front and rear of the stock U-bolts holding the leaf springs to the axle.

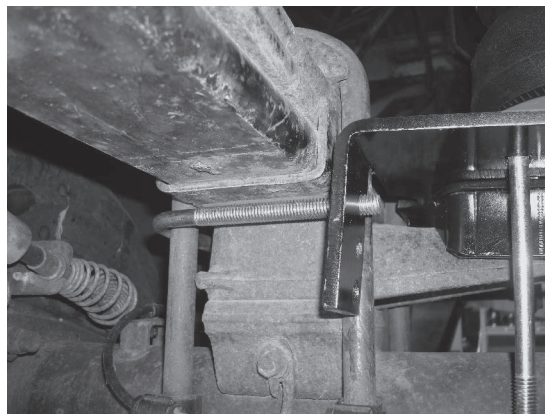

Use closest hole to the leaf spring.

fig. 46

4. Cap U-bolts with two 3/8" flat washers (V), and two 3/8"-16 nylon nuts (U) and evenly tighten only enough to draw the bracket up against the stock U-bolt at this time (fig. 47). Repeat for the other side. Make sure the bracket rests against the stock U-bolts (Fig. 48).

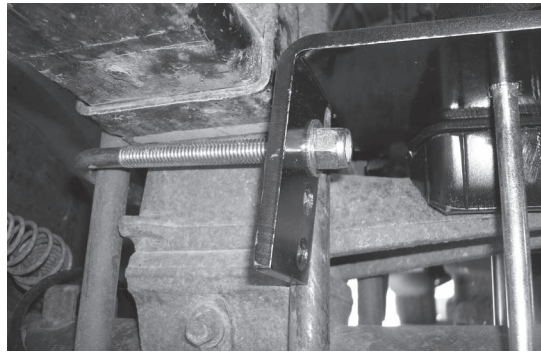

Evenly tighten only enough to draw the lower bracket to the Stock U-bolts at this time

fig. 47

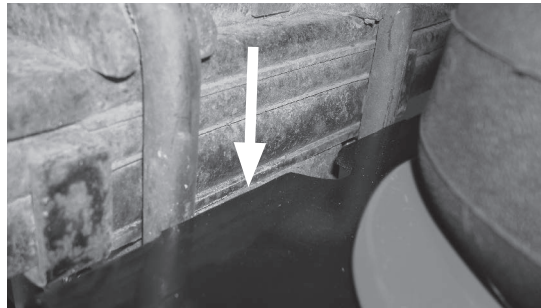

Bracket must be up against the stock U-bolts and the flanges of the lower bracket must be locked forward and behind the stock U-bolts.

fig. 48

5. Insert the remaining 3/8"-16 X 10" carriage bolts (DD) through the remaining square hole in the lower bracket (forward of the axle) opposite of the one previously installed during the bellows assembly. Set the clamp bar (G) over the carriage bolts (DD) and cap with two 3/8" flat washers (V) and 3/8" nylon nuts (U) (Fig. 49). Repeat for the opposite side. Leave loose at this time.

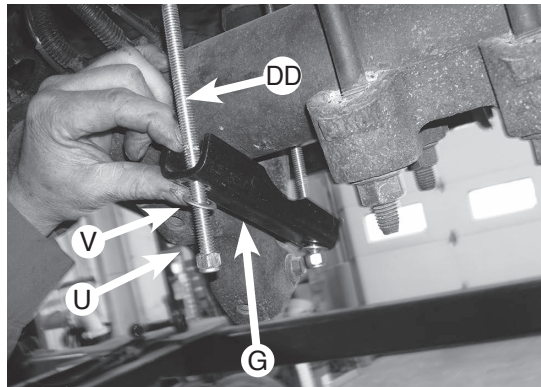

Set the axle clamp bar over the 3/8"-16 x 10" carriage bolts and cap with 3/8" flat washer and 3/8" nylon lock nut. Leave loose at this time.

fig. 49

- Tighten the axle clamp bar hardware evenly until it touches the axle (see note below). Torque the axle clamp bar bolts to 16 lb.-ft. (Fig. 50). Repeat for the opposite side. Trim the 3/8"-16 X 10" carriage bolts below the nylon lock nuts if necessary.

NOTE

Do not pinch the hard brake line on the passenger side while tightening.

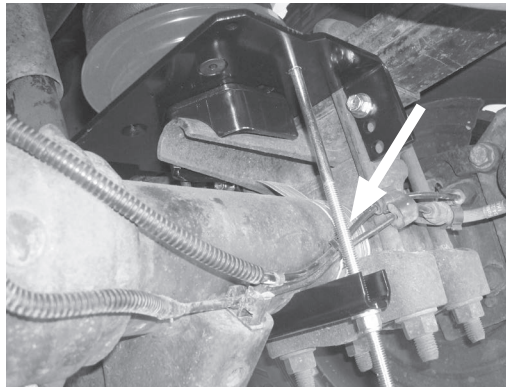

It may be necessary on some models to not tighten the axle clamp bar evenly on the right side (passenger's side) so that the clamp bar will clear the hard brake line.

fig. 50

- Torque the leaf spring U-bolt hardware to 10 lb.-ft. Repeat for the opposite side. Once tight, the upper and lower brackets will not be parallel and may look like they are out of alignment. This condition will be OK because of the way the lower bracket and upper bracket mounts are designed. Some variance from one unit to another is considered normal.
- Raise the axle up all the way (if not already done so) and remove the jack stands or equivalent used during the installation.
- Once the lower bracket hardware is tight, snug the lower mounting plate/swivel cup bracket mounting hardware with an open end wrench (Fig. 51).

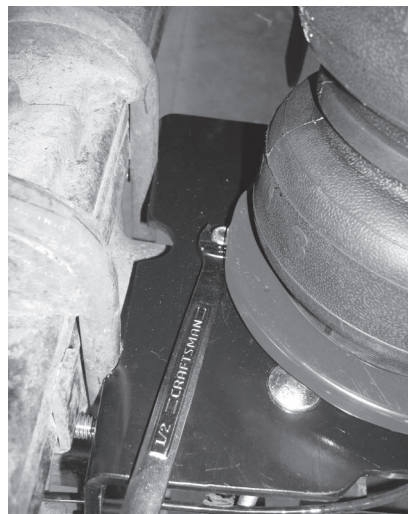

Tighten lower main plate/swivel cup mounting hardware once the lower bracket is in position and tight.

fig. 51

- Finish installation of the air springs by tying together the soft and hard brake lines that are close to the lower bellows roll plate on the driver side (Fig. 52).

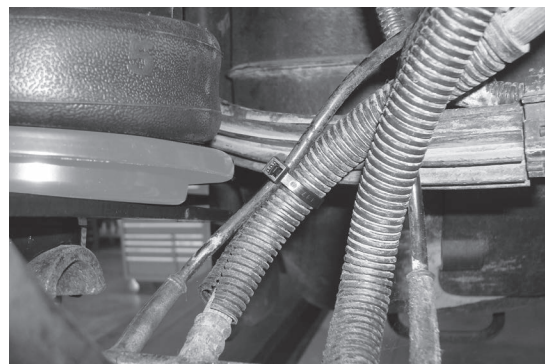

fig. 52

INSTALLING THE AIR LINES

1. Choose a convenient location for mounting the inflation valve valves. Popular locations for the inflation valve are:
 - a. The wheel well flanges
 - b. The license plate recess in bumper
 - c. Under the gas cap access door
 - d. Through the license plate

NOTE

Whatever the chosen location, make sure there is enough clearance around the inflation valves for an air chuck.

2. Drill two 5/16" holes to install the inflation valves.
3. Cut the air line assembly in two equal lengths.

CAUTION

WHEN CUTTING OR TRIMMING THE AIR LINE, USE THE INCLUDED HOSE CUTTER. A CLEAN, SQUARE CUT WILL ENSURE AGAINST LEAKS. DO NOT USE WIRE CUTTERS OR SCISSORS TO CUT THE AIR LINE. THESE TOOLS MAY FLATTEN OR CRIMP THE AIR LINE CAUSING IT TO LEAK AROUND THE O-RING SEAL INSIDE THE ELBOW FITTING (FIG. 53).

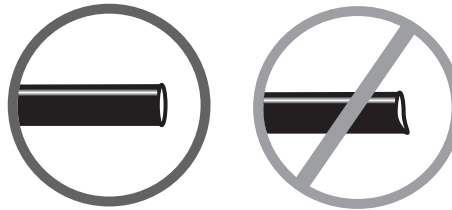

fig. 53

4. Place a 5/16" nut and star washer on the air valve. Leave enough of the inflation valve in front of the nut to extend through the hole and have room for the rubber washer, flat washer, and 5/16" nut and cap. There should be enough valve exposed after installation – approximately 1/2" – to easily apply a pressure gauge or an air chuck (Fig. 54).

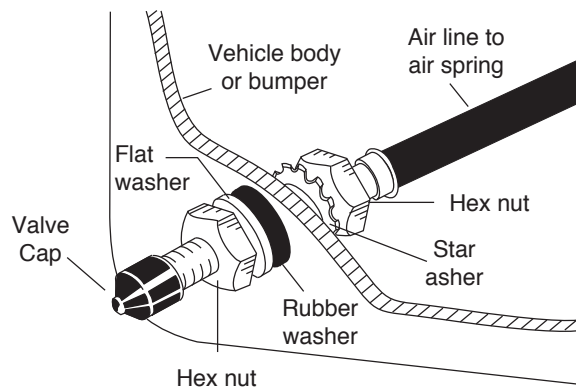

fig. 54

5. Push the inflation valve through the hole and use the rubber washer, flat washer, and another 5/16" nut to secure it in place. Tighten the nuts to secure the assembly.

- Route the air line along the frame to the air fitting on the air spring (Fig. 55). Keep AT LEAST 6" of clearance between the air line and heat sources, such as the exhaust pipes, muffler, or catalytic converter. Avoid sharp bends and edges. Use plastic tie straps to secure the air line to fixed points along the chassis. Be sure that the tie straps are tight, but do not pinch the air line. Leave at least 2" of slack to allow for any movement that might pull on the air line.

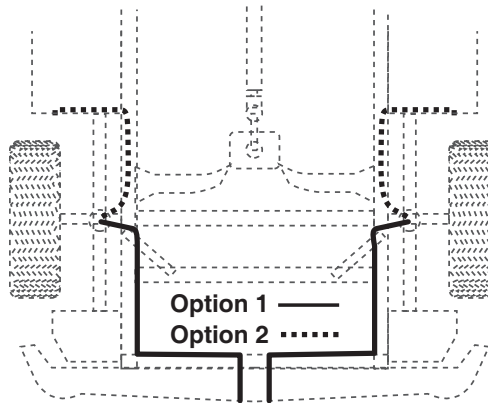

fig. 55

- Before installing the right (passenger) side hose, install the hose heat shield over the hose (Fig. 56). Once the hose has been inserted into the fitting, push the hose heat shield up to the fitting.



Hose heat shield shown in place on the right side (passenger) of the vehicle. Make sure heat shield is pushed up against the fitting once the hose is installed.

fig. 56

- Cut off the air line, leaving approximately 12" of extra air line. A clean square cut will prevent leaks. Insert the air line into the air fitting. This is a push-to-connect fitting. Simply push the air line into the 90° swivel fitting until it bottoms out (9/16" of air line should be in the fitting).

INSTALLING THE HEAT SHIELD

- Bend tabs to provide a dead air space between exhaust pipe and heat shield (Fig. 57). Attach the heat shield to the exhaust pipe using the clamps. Bend the heat shield for maximum clearance to the air spring.



The shield is shown in position with air gap between it and the exhaust pipe.

fig. 57

NOTE

Some vehicles have large resonators in this area, it will be necessary to double up on the clamps to fit these models (Fig. 58).

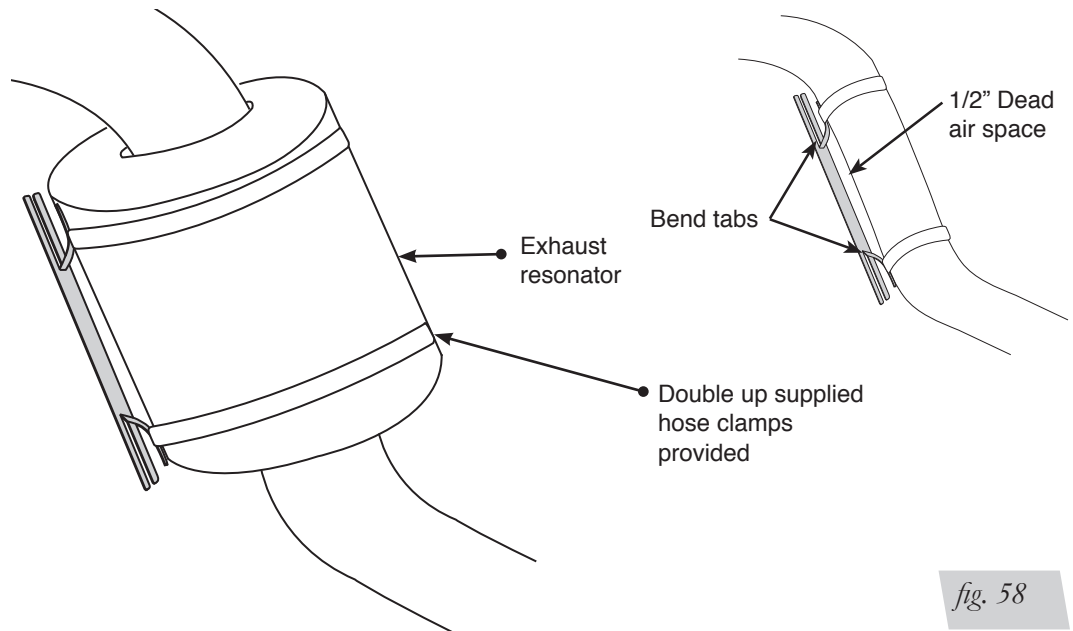

fig. 58

CHECKING FOR LEAKS

1. Inflate the air spring to 30 PSI.
2. Spray all connections and the inflation valves with a solution of 1/5 liquid dish soap and 4/5 water. Spot leaks easily by looking for bubbles in the soapy water.
3. After the test, deflate the springs to the minimum pressure required to restore the system to normal ride height. Do not deflate to lower than 5 PSI.
4. Check the air pressure again after 24 hours. A 2 - 4 PSI loss after initial installation is normal. Retest for leaks if the loss is more than 5 lbs.

FIXING LEAKS

1. If there is a problem with the swivel fitting:
 - a. Check the air line connection by deflating the spring and removing the line by pulling the collar against the fitting and pulling firmly on the air line. Trim 1" off the end of the air line. Be sure the cut is clean and square (see Fig. 52). Reinsert the air line into the push-to-connect fitting.
 - b. Check the threaded connection by tightening the swivel fitting another 1/2 turn. If it still leaks, deflate the air spring, remove the fitting, and re-coat the threads with thread sealant. Reinstall by hand tightening as much as possible and then use a wrench for an additional two turns.
2. If there is a problem with the inflation valve:
 - a. Check the valve core by tightening it with a valve core tool.
 - b. Check the air line by removing the air line from the barbed type fitting. Cut the air line off a few inches in front of the fitting and use a pair of pliers or vice grips to pull/twist the air line off of the fitting.



DO NOT CUT OFF THE AIR LINE COMPLETELY AS THIS WILL USUALLY NICK THE BARB AND RENDER THE FITTING USELESS.

3. If the preceding steps have not resolved the problem, call Air Lift customer service at (800) 248-0892.

FINISHED INSTALLATION PHOTOS

1. The following shows the finished installation of both sides (Figs. 59, 60, 61 and 62).

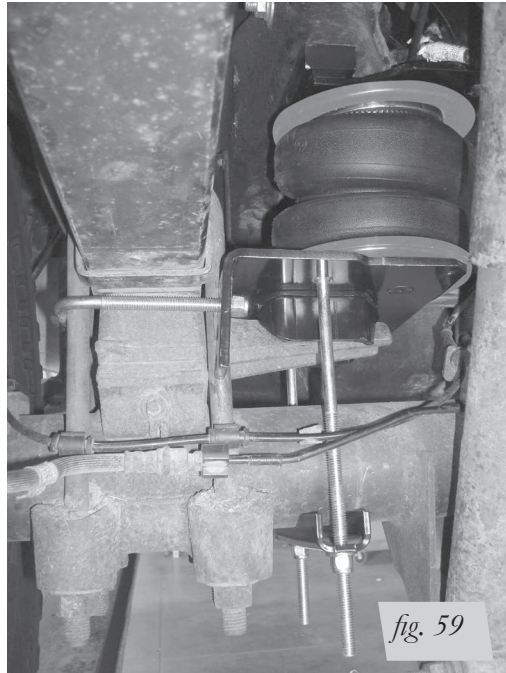

Back, left (driver side)
rear view of the kit installed.

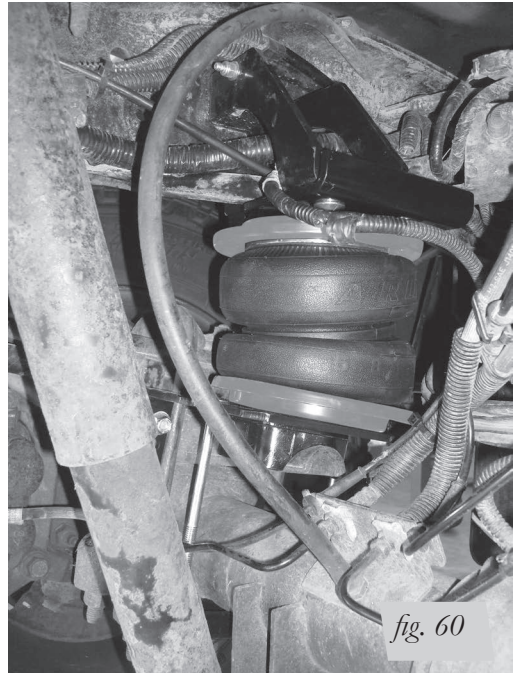

Back center, left (driver side)
rear view of the kit installed.



Back right (passenger side)
rear view of the kit installed.

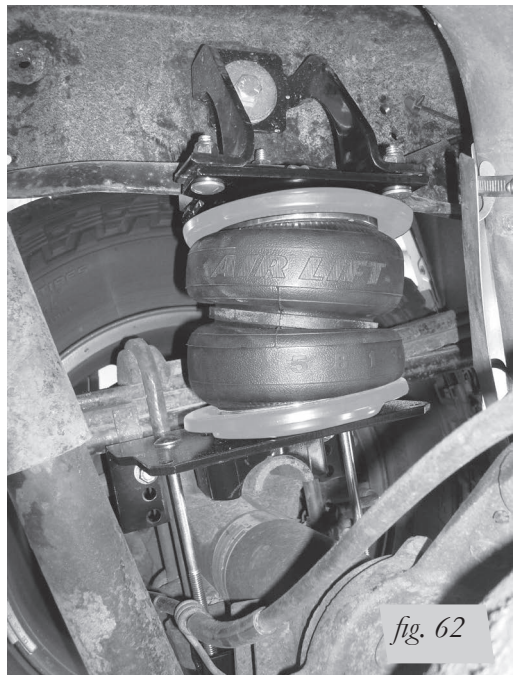

Back right (passenger side)
forward, center view of the kit installed.

Before Operating

INSTALLATION CHECKLIST (To be completed by installer)

- Clearance test — Inflate the air springs to 60 PSI and ensure there is at least 1/2" clearance around each bellow, away from anything that might rub against them. Be sure to check the tire, brake drum, frame, shock absorbers and brake cables.
- Leak test before road test — Inflate the air springs to 60 PSI, check all connections for leaks with a soapy water solution. See the *Checking for Leaks* section for tips on how to spot leaks. All leaks must be eliminated before the vehicle is road tested.
- Heat test — Be sure there is sufficient clearance from any heat sources — at least 6" for air springs and air lines. If a heat shield was included in the kit, install it. If there is no heat shield, but one is required, call (800) 248-0892.
- Fastener test — Recheck all bolts for proper torque. Re-torque after 100 miles.
- Road test — The vehicle should be road tested after the preceding tests. Inflate the air springs to 25 PSI (50 PSI if the vehicle is loaded). Drive the vehicle 10 miles and recheck for clearance, loose fasteners and air leaks.
- Operating instructions — If professionally installed, the installer should review the *Product Use, Maintenance and Servicing* section with the owner. Be sure to provide the owner with all of the paperwork which came with the kit.

Technician's Signature _____

Date _____

POST-INSTALLATION CHECKLIST

- Overnight leak down test — Recheck air pressure after the vehicle has been used for 24 hours. If the pressure has dropped more than 5 PSI, then there is a leak that must be fixed. Either fix the leak yourself or return to the installer for service.
- Air pressure requirements — Regardless of load, the air pressure should always be adjusted to maintain ride height at all times.
- Thirty day or 500 mile test — Recheck the air spring system after 30 days or 500 miles, whichever comes first. If any part shows signs of rubbing or abrasion, the source should be identified and moved, if possible. If it is not possible to relocate the cause of the abrasion, the air spring may need to be remounted. If professionally installed, the installer should be consulted. Check all fasteners for tightness.

Product Use, Maintenance and Servicing

| Minimum Recommended Pressure | Maximum Air Pressure |
|------------------------------|----------------------|
| 5 PSI | 100 PSI |

MAINTENANCE GUIDELINES

NOTE

By following the steps below, vehicle owners will obtain the longest life and best results from their air springs.

1. Check the air pressure weekly.
2. Always maintain normal ride height. Never inflate beyond 100 PSI.
3. If you develop an air leak in the system, use a soapy water solution (1/5 liquid dish soap and 4/5 water) to check all air line connections and the inflation valve core before deflating and removing the air spring.

CAUTION

FOR YOUR SAFETY AND TO PREVENT POSSIBLE DAMAGE TO YOUR VEHICLE, DO NOT EXCEED MAXIMUM GROSS VEHICLE WEIGHT RATING (GVWR), AS INDICATED BY THE VEHICLE MANUFACTURER. ALTHOUGH YOUR AIR SPRINGS ARE RATED AT A MAXIMUM INFLATION PRESSURE OF 100 PSI, THE AIR PRESSURE ACTUALLY NEEDED IS DEPENDANT ON LOAD AND GVWR.

4. Loaded vehicles require at least 25 PSI or more. A “loaded vehicle” refers to a vehicle with a heavy bed load, a trailer, or both. As discussed above, never exceed GVWR, regardless of air spring, air pressure, or other load assist. The springs in this kit will support approximately 40 lbs. of load (combined on both springs) for each 1 PSI of pressure. The required air pressure will vary depending on the state of the original suspension. Operating the vehicle below the minimum air spring pressure will void the Air Lift warranty.
5. When increasing load, always adjust the air pressure to maintain the normal ride height. Increase or decrease pressure from the system as necessary to attain normal ride height for optimal ride and handling. Remember that loads carried behind the axle (including tongue loads) require more leveling force (pressure) than those carried directly over the axle.
6. Always add air to springs in small quantities, checking the pressure frequently.
7. Should it become necessary to raise the vehicle by the frame, make sure the system is at minimum pressure (5 PSI) to reduce the tension on the suspension/brake components. Use of on board leveling systems do not require deflation or disconnection.
8. Periodically check the air spring system fasteners for tightness. Also, check the air springs for any signs of rubbing. Realign if necessary.
9. On occasion, give the air springs a hard spray with a garden hose in order to remove mud, sand, gravel or other abrasive debris.

TROUBLESHOOTING GUIDE

1. Leak test the air line connections, the threaded connection into the air spring, and all fittings in the control system.
2. Inspect the air lines to be sure none are pinched. Tie straps may be too tight. Loosen or replace the strap and replace leaking components.
3. Inspect the air line for holes and cracks. Replace as needed.
4. Look for a kink or fold in the air line. Reroute as needed.

If the preceding steps do not solve the problem, it is possibly caused by a failed air spring — either a factory defect or an operating problem. Please call Air Lift at (800) 248-0892 for assistance.

FREQUENTLY ASKED QUESTIONS

Q. Will installing air springs increase the weight ratings of a vehicle?

No. Adding air springs will not change the weight ratings (GAWR, GCWR and/or GVWR) of a vehicle. Exceeding the GVWR is dangerous and voids the Air Lift warranty.

Q. Is it necessary to keep air in the air springs at all times and how much pressure will they need?

For LoadLifter 5000 Ultimate, the recommended minimum air pressure is 5 PSI, but it can safely be run at zero air pressure.

Q. Is it necessary to add a compressor system to the air springs?

No. Air pressure can be adjusted with any type of compressor as long as it can produce sufficient pressure to service the springs. Even a bicycle tire pump can be used, but it's a lot of work.

Q. How long should air springs last?

If the air springs are properly installed and maintained they can last indefinitely.

Q. Will raising the vehicle on a hoist for service work damage the air springs?

No. The vehicle can be lifted on a hoist for short-term service work such as tire rotation or oil changes. However, if the vehicle will be on the hoist for a prolonged period of time, support the axle with jack stands in order to take the tension off of the air springs.

TUNING THE AIR PRESSURE

Pressure determination comes down to three things — level vehicle, ride comfort and stability.

1. Level vehicle

If the vehicle's headlights are shining into the trees or the vehicle is leaning to one side, then it is not level (Fig. 2.1). Raise the air pressure to correct either of these problems and level the vehicle.

2. Ride comfort

If the vehicle has a rough or harsh ride it may be due to either too much pressure or not enough (Fig. 2.2). Try different pressures to determine the best ride comfort.

3. Stability

Stability translates into safety and should be the priority, meaning the driver may need to sacrifice a perfectly level and comfortable ride. Stability issues include roll control, bounce, dive during braking and sponginess (Fig. 2.3). Tuning out these problems usually requires an increase in pressure.



Bad headlight aim

fig. 2.1



Rough ride

fig. 2.2

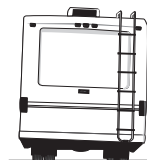

Sway and
body roll

fig. 2.3

GUIDELINES FOR ADDING AIR

1. Start with the vehicle level or slightly above.
2. When in doubt, always add air.
3. If the front of the vehicle dives while braking, increase the pressure in the front air bags, if equipped.
4. If it is ever suspected that the air bags have bottomed out, increase the pressure (Fig. 2.4).
5. Adjust the pressure up and down to find the best ride.
6. If the vehicle rocks and rolls, adjust the air pressure to reduce movement.
7. It may be necessary to maintain different pressures on each side of the vehicle. Loads such as water, fuel, and appliances will cause the vehicle to be heavier on one side (Fig. 2.5). As much as a 50 PSI difference is not uncommon.



Bottoming out

fig. 2.4

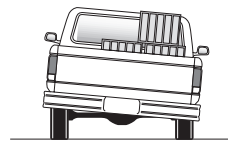

Unlevel

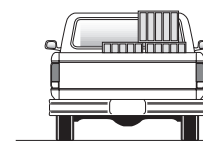

Level

fig. 2.5

Choosing the Right On-Board Air Compressor System

60 DAY NO QUESTIONS ASKED, MONEY-BACK GUARANTEE

TWO-YEAR COMPRESSOR SYSTEM WARRANTY

Add an on-board air compressor system to inflate and deflate your air springs automatically or with the touch of a button — from inside or outside of the vehicle.

- For convenient, on-the-go control of your air springs, add an Air Lift on-board air compressor system.
- Air Lift on-board air compressor systems eliminate the search for gas stations that have a working compressor, saving you time, energy and money.
- All systems include a compressor, controller and all parts needed for easy installation.

1. Choose single or dual path inflation (see illustrations at right)

2. Choose wireless, analog control or automatic

- **Wireless:** Control your air springs from inside or outside the vehicle. Easiest installation — no wires to the cab.
- **Analog:** In-cab control of your air springs. Economically priced.
- **Automatic:** Self-leveling system, keeps the vehicle level no matter what.

3. Choose heavy or standard duty compressor

- **Standard duty:** A standard duty compressor will work well for most customers who use their system on an intermittent basis.
- **Heavy duty:** For daily use, consider the heavy-duty compressor — it inflates faster and more quietly than the standard compressor.

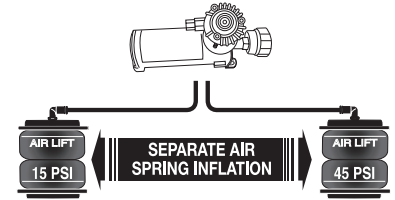

Dual path systems Air springs are controlled separately to allow for different air pressure from side-to-side. Perfect for uneven or top-heavy loads.

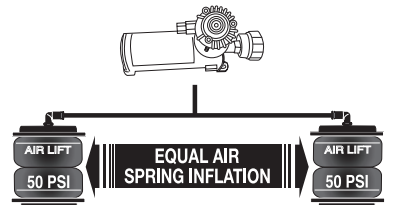

Single path systems Two springs will inflate at the same time. Good for loads that are evenly distributed from left-to-right or front-to-back.

Visit www.airliftcompany.com for more detailed info on compressor systems.

| | WIRELESS | ANALOG | AUTOMATIC |
|-----------|--|--|---|
| DUAL PATH | <p>WirelessAIR™ <i>OUR PREMIUM SYSTEM!</i></p> <ul style="list-style-type: none"> • Easy installation • Includes heavy-duty compressor <p>P/N 72000</p> | <p>LoadCONTROLLER™ <i>Dual</i></p> <p>Compact, economically priced control.</p> <p>DEFLATE LEFT INFLATE BOTH DEFLATE RIGHT</p> <p>P/N Standard Duty Compressor 25850; P/N Heavy Duty Compressor 25854</p> | <p>SmartAIR™ II</p> <ul style="list-style-type: none"> • Easy installation • Automatic self-leveling system • No in-cab controls required |
| | <p>WirelessONE™</p> <ul style="list-style-type: none"> • Easy installation • Includes standard-duty compressor <p>P/N 25870</p> | <p>LoadCONTROLLER™ <i>Single</i></p> <p>Compact, economically priced control.</p> <p>DEFLATE BOTH INFLATE BOTH</p> <p>P/N Standard Duty Compressor 25852; P/N Heavy Duty Compressor 25856</p> | <p>Single Path P/N 25490, Dual Path P/N 25491</p> |



Limited Warranty and Return Policy

WHAT THIS WARRANTY COVERS

Air Lift Company provides a warranty to the original purchaser of its Load Support Products, for the periods of time listed below, by product line, from the date of original purchase, that the products will be free from defects in workmanship and materials when used on cars and trucks as specified by Air Lift Company and under normal operating conditions, subject to the requirements and exclusions set forth below.

WHAT THIS WARRANTY DOES NOT COVER

The warranty does not apply to products that have been improperly applied, improperly installed, or which have not been maintained in accordance with installation instructions furnished with all products. This warranty does not apply and is void if damage or failure is caused by: accident, abuse, misuse (including but not limited to racing or off-road activities or commercial use), abnormal use, faulty installation, liquid contact, fire, earthquake or other external cause; operating the product outside Air Lift Company's instructions, specifications or guidelines; or service, alteration, maintenance or repairs performed by anyone other than Air Lift Company to the product from its purchased condition. This warranty also does not apply to: consumable parts, such as batteries; cosmetic damage, including but not limited to scratches or dents; defects caused by normal wear and tear or otherwise due to the normal aging of the product, or if any serial or identification number has been removed or defaced from the product. Air Lift Company reserves the right to change the design of any product without assuming any obligation to modify any product previously manufactured.

LIMITATION OF LIABILITY

To the extent permitted by law, this warranty and the remedies set forth herein are exclusive and in lieu of all other warranties, remedies and conditions, whether oral, written, statutory, express or implied. AIR LIFT COMPANY DISCLAIMS ALL STATUTORY AND IMPLIED WARRANTIES, INCLUDING WITHOUT LIMITATION, WARRANTIES OF MERCHANTABILITY AND FITNESS FOR A PARTICULAR PURPOSE AND WARRANTIES AGAINST HIDDEN OR LATENT DEFECTS TO THE EXTENT PERMITTED BY LAW. To the extent such warranties cannot be disclaimed, such implied warranties shall apply only for the warranty period specified above. Please note that some states do not allow limitation on how long an implied warranty (or condition) lasts. So the above limitation may not apply to you.

Except as provided in this warranty and to the extent permitted by law, Air Lift Company shall not be liable for any direct, special, incidental or consequential damages resulting from any breach of warranty or condition, or arising in connection with the sale, use or repair of air lift products, or under any other legal theory, including but not limited to loss of use, loss of revenue, loss of actual or anticipated profits, loss of the use of money, loss of business, loss of opportunity, loss of goodwill, and loss of reputation. Air Lift Company's maximum liability shall not in any case exceed the purchase price paid by you for the Air Lift product. Please note that some states do not allow the exclusion or limitation of incidental or consequential damages, so the above limitation or exclusion may not apply to you.

HOW TO GET SERVICE

If a defect in workmanship or materials causes your Air Lift product to become inoperable within the warranty period, before returning any defective product, call Air Lift Company at (800) 248-0892 in the U.S. and Canada (elsewhere, (517) 322-2144) to obtain a Returned Materials Authorization (RMA) number. The consumer shall be responsible for removing (labor charges) the defective product from the vehicle and returning it, shipping costs prepaid, to Air Lift Company for verification. Returns to Air Lift Company must be postage prepaid and sent to: Air Lift Company • 2727 Snow Road • Lansing, MI • 48917. You must prove to the satisfaction of Air Lift Company the date of original purchase of your Air Lift product. You must also enclose the RMA number and a return address. A minimum \$10 shipping and handling charge will apply to all warranty claims. You must also pack the product to minimize the risk of it being damaged in transit. If we receive a product in damaged condition as the result of shipping, we will notify you and you must seek a claim with the shipper.

WHAT AIR LIFT COMPANY WILL DO

If you submit a valid claim to Air Lift Company during the warranty period, Air Lift Company will, at its option, repair your Air Lift product or furnish you with a new or rebuilt product. Air Lift Company will not reimburse you for repairs or replacement parts provided by other parties. Your repaired or replacement Air Lift product will be returned to you (subject to payment of the required warranty claim shipping and handling charge) and it will be covered under the warranty for the balance of the warranty period, if any. When a product or part is replaced, any replacement item becomes your property and the replaced item becomes property of Air Lift Company. You are responsible for installation/reinstallation (labor charges) of the product.

HOW THE LAW RELATES TO THIS WARRANTY

This warranty gives you specific legal rights and you may also have other rights which vary from state to state. By this warranty, Air Lift Company does not limit or exclude your rights except as allowed by law. To fully understand your rights, you should consult the laws of your state.

SPECIFIC LOAD SUPPORT WARRANTY PERIODS BY PRODUCT LINE

| | | | |
|--------------------------------|------------------|--------------------------------------|----------------|
| LoadLifter 5000™ Ultimate..... | Lifetime Limited | WirelessAIR™..... | 2 Year Limited |
| LoadLifter 5000™..... | Lifetime Limited | WirelessONE™..... | 2 Year Limited |
| RideControl™..... | Lifetime Limited | LoadController™ Single and Dual..... | 2 Year Limited |
| Air Lift 1000™..... | Lifetime Limited | LoadController™ I and II..... | 2 Year Limited |
| AirCell™..... | Lifetime Limited | SmartAir™ II..... | 2 Year Limited |
| SlamAir™..... | Lifetime Limited | Other Accessories..... | 2 Year Limited |

Replacement Information

If you need replacement parts, contact the local dealer or call Air Lift customer service at (800) 248-0892. Most parts are immediately available and can be shipped the same day.

Contact Air Lift Company customer service at (800) 248-0892, first if:

- Parts are missing from the kit.
- Need technical assistance on installation or operation.
- Broken or defective parts in the kit.
- Wrong parts in the kit.
- Have a warranty claim or question.

Contact the retailer where the kit was purchased:

- If it is necessary to return or exchange the kit for any reason.
- If there is a problem with shipping if shipped from the retailer.
- If there is a problem with the price.

Contact Information

If you have any questions, comments or need technical assistance, contact our customer service department by calling (800) 248-0892, Monday through Friday. For calls from outside the USA or Canada, our local number is (517) 322-2144.

For inquiries by mail, our address is PO Box 80167, Lansing, MI 48908-0167. Our shipping address for returns is 2727 Snow Road, Lansing, MI 48917.

Contact us anytime by email at sales@airliftcompany.com or at airliftcompany.com.

Need Help?

Contact our customer service department by calling (800) 248-0892, Monday through Friday. For calls from outside the USA or Canada, call (517) 322-2144.

**Register your warranty online at
www.airliftcompany.com/warranty**



Thank you for purchasing Air Lift products — the professional installer's choice!

Air Lift Company • 2727 Snow Road • Lansing, MI 48917 or PO Box 80167 • Lansing, MI 48908-0167
Toll Free (800) 248-0892 • Local (517) 322-2144 • Fax (517) 322-0240 • www.airliftcompany.com

Printed in the USA
JJC-0516