

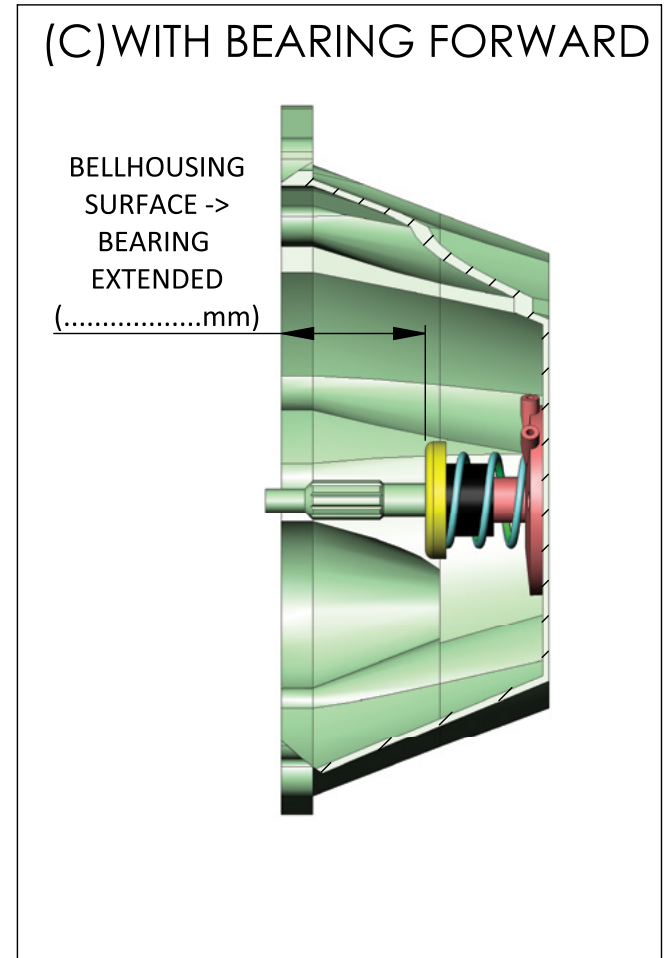

TSB-203 CLUTCH RELEASE BEARING SETUP & CHECK

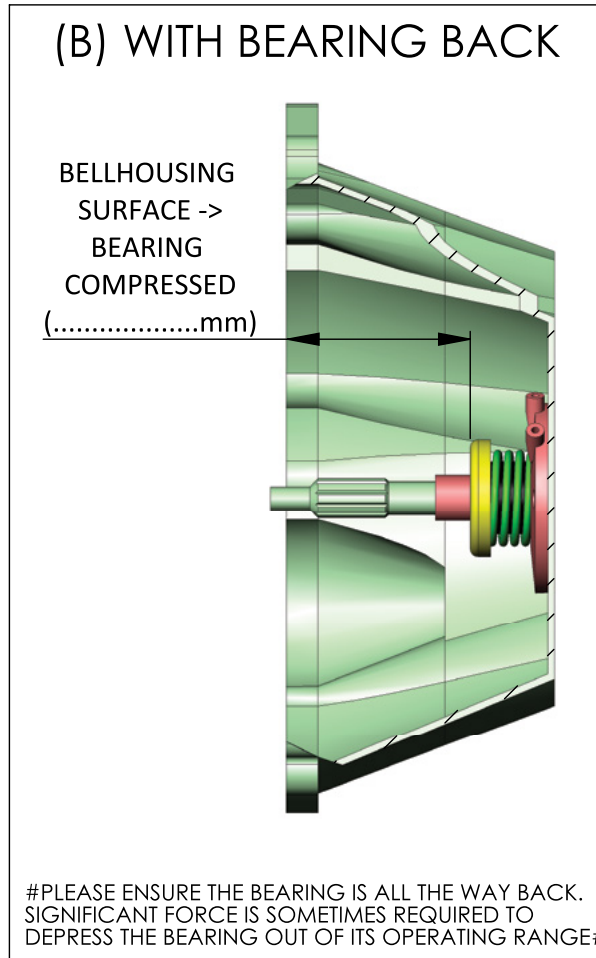
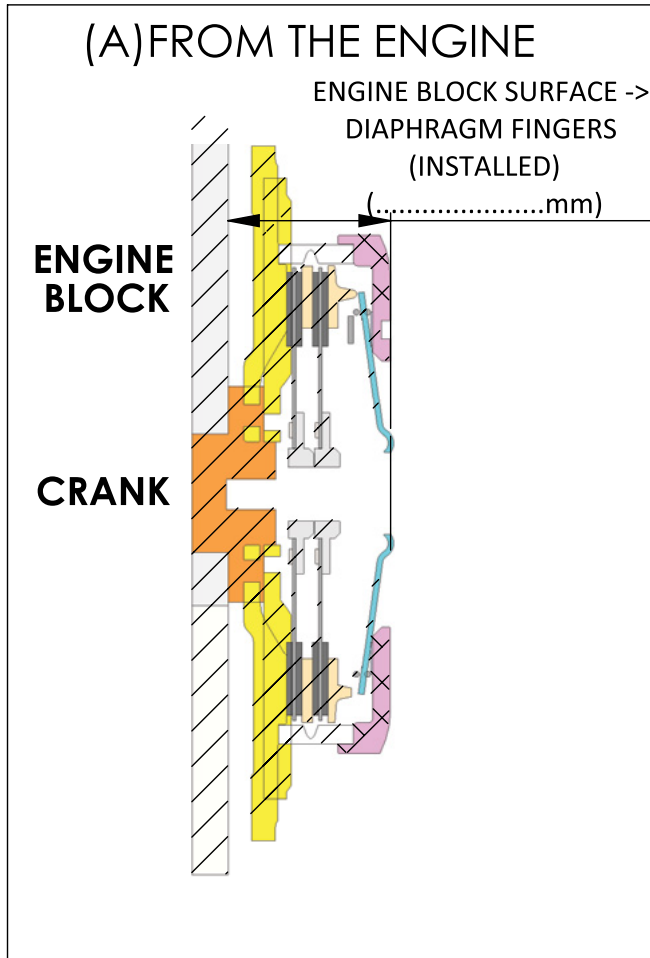

CALCULATED VALUES MUST BE EQUAL TO OR LARGER THAN THE VALUES ON THE RIGHT

ROOM FOR CLUTCH WEAR = $B-A = \dots \geq 5\text{mm}$

CLUTCH RELEASE TRAVEL = $A-C = \dots \geq 10\text{mm}$

Scan QR to view Clutch Tech video



LEADING BRANDS

