

advanced FLOW engineering Takeda Dynamic Air Scoop

Instruction Manual

P/N: 56-70005S/ 56-70005SR/ 56-70005SL/ 56-70005SE

Make: Hyundai
Make: Hyundai

Model: Elantra GT
Model: i30

Year: 2017-2020
Year: 2017-2020

Engine: L4-1.6L(t)
Engine: L4-1.6L(t)



- Please read the entire instruction manual before proceeding.
- Ensure all components listed are present.
- If you are missing any of the components, call customer support at 951-493-7185.
- Ensure you have all necessary tools before proceeding.
- Do not attempt to work on your vehicle when the engine is hot.
- Retain factory parts for future use.

Label	Qty.	Description	Part Number
A1	1	Scoop (Black)	05-5670005B3
A2	1	Scoop (Red)	05-5670005R3
A3	1	Scoop (Blue)	05-5670005L3
A4	1	Scoop (Neon Green)	05-5670005E3
B	1	Magnet with Stud	03-50660

Installation will require the following tools:

8mm socket or nut driver, flat-blade screwdriver or plastic trim prybar, 10mm nut driver, 10mm wrench.

Two people are recommended for bumper removal and re-installation.



ATTENTION: This Installation requires the removal of the front bumper. It is highly recommended to use two people for removal and re-installation.

A1/A2/A3/A4

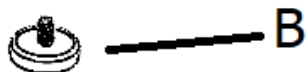
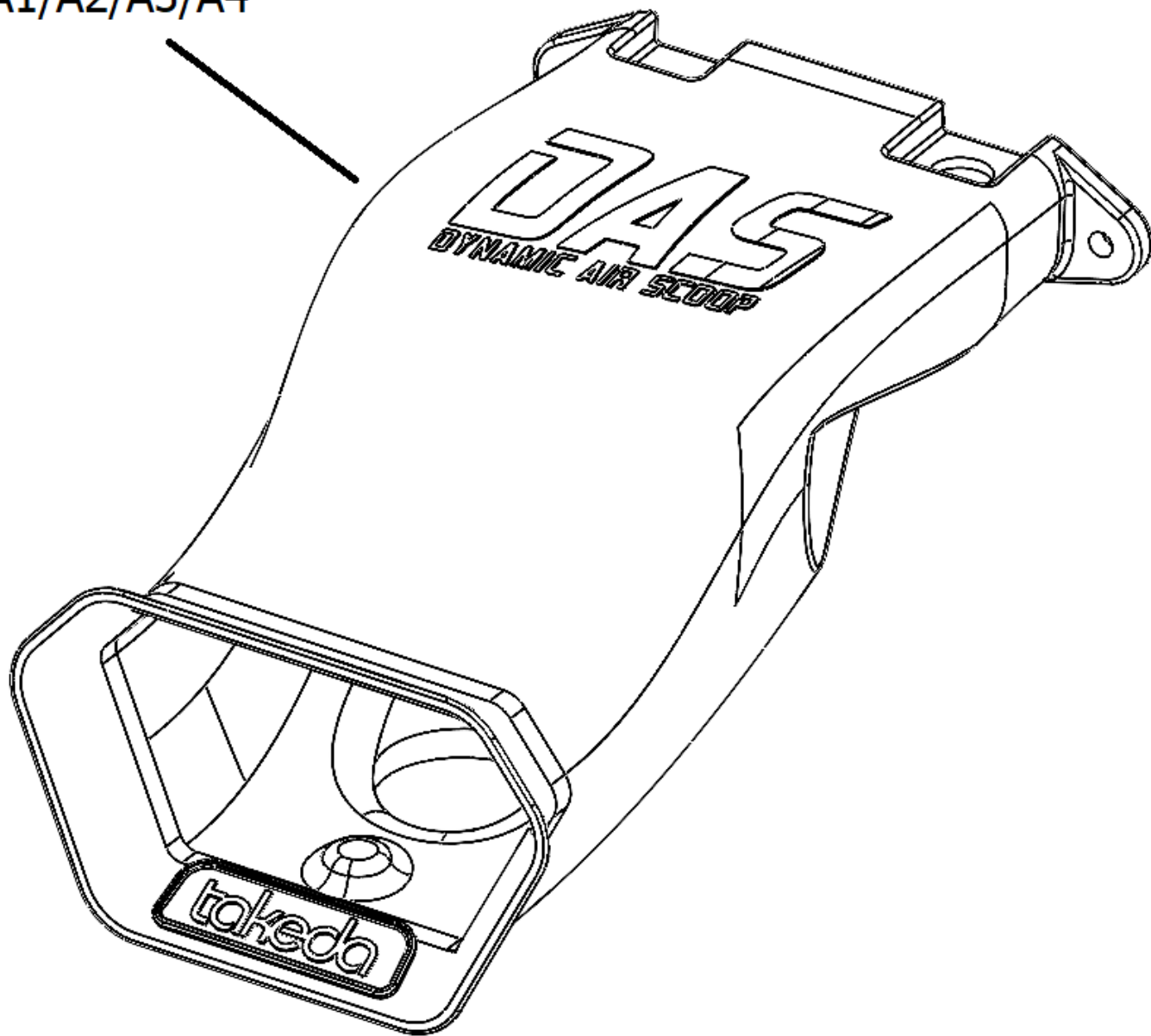



Figure A

Refer to Figure A for Step 1

Step 1: Lift the hood of the vehicle. Using the flat-blade screwdriver or a plastic trim tool, remove the six push rivets on the top side of the bumper. Remember to save the push rivets, they will be needed for re-installation.

**Figure B**

Refer to Figure B for Steps 2-3

Step 2: Using the same tool used in the previous step, remove the three push clips where the inner fender liner meets the bumper on the passenger side.

Step 3: Using an 8mm nut driver or socket, remove the screw in the fender. Keep this screw, it will be needed for reinstallation.

Repeat Steps 2 and 3 on the driver side.

**Figure C****Refer to Figure C for Step 4**

Step 4: Underneath the bumper, remove the six push clips along the front edge.



Refer to Figure D for Step 5

Step 5: Two people are recommended for this step. With all the push clips and both screws removed, gently but firmly pull on the fender sides of the bumper.



Refer to Figure E for Step 6

Step 6: Two people are recommended for this step. Once the sides of the bumper are loose, gently but firmly pull out on the bumper under the headlights. Be sure to hold the bumper securely, as it will want to fall to the ground once these clips are loose.

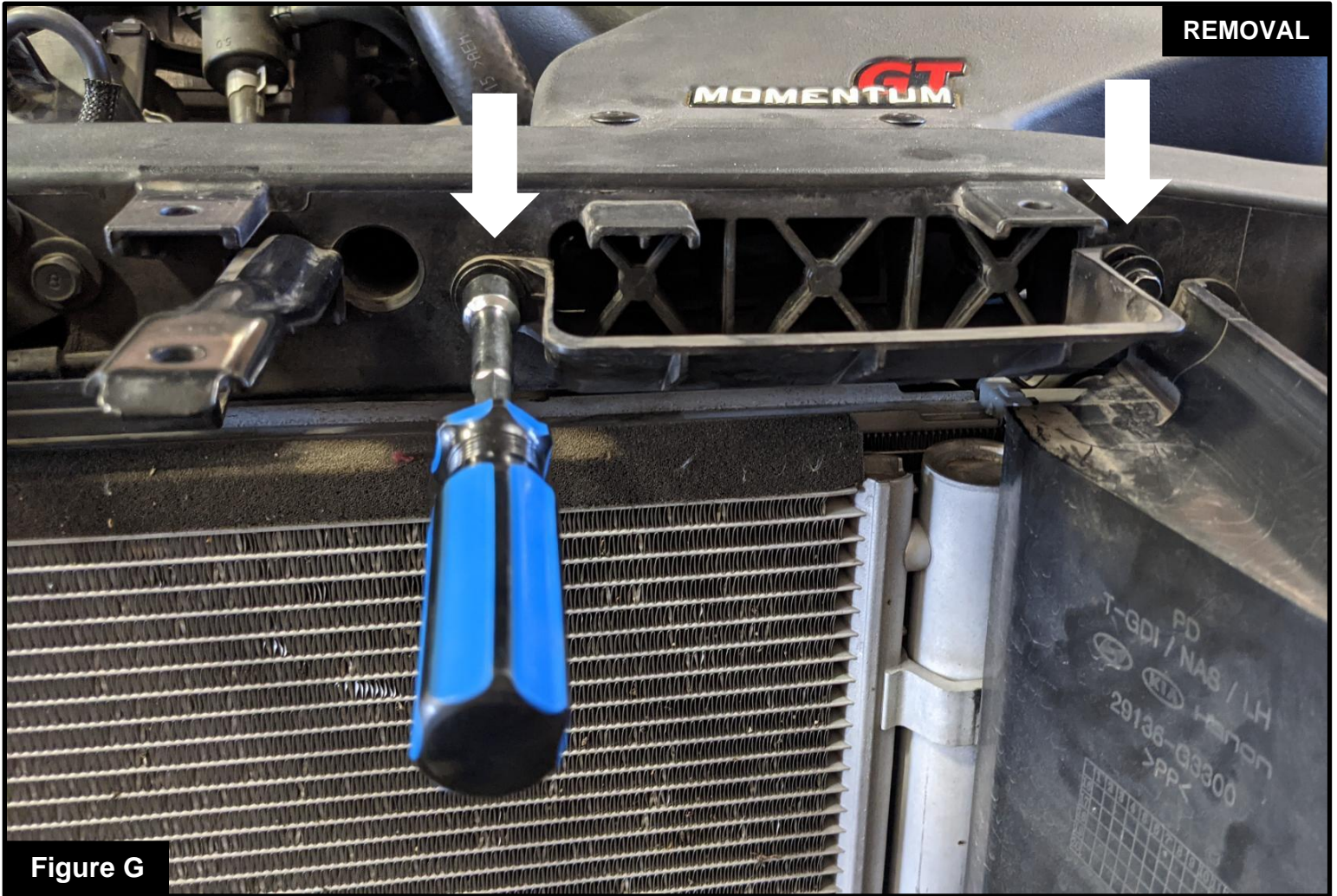

Refer to Figure G for Step 9

Step 9: Using a 10mm nut driver or socket, remove the screws holding the factory scoop. Keep the screws, they will be re-used for installation of the Takeda Dynamic Air Scoop.

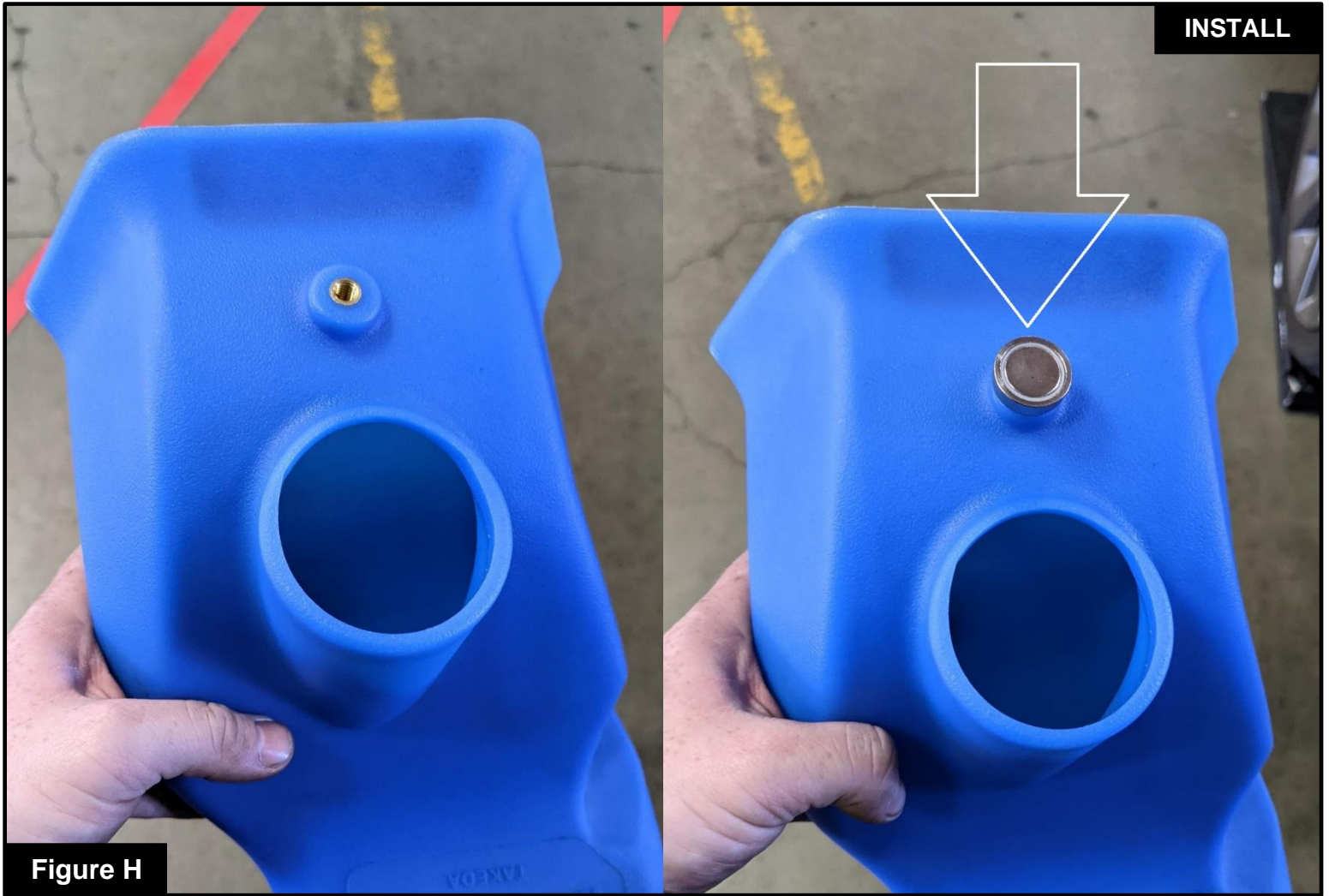

Refer to Figure H for Step 10

Step 10: Install the studded magnet into the threaded insert on the bottom of the Takeda Dynamic Air Scoop. No tool is needed for this, only tighten it by hand.

**Figure I****Refer to Figure I for Step 11**

Step 11: Line up the mounting holes on the Takeda Dynamic Air Scoop with the factory threaded holes on the radiator support. The magnet will hold the Takeda Dynamic Air Scoop to the interior bumper.



Refer to Figure J for Step 12

Step 12: Re-using the factory scoop screws removed in step 9, secure the Dynamic Air Scoop with a 10mm nut driver/socket and a 10mm wrench.

**Figure K**

Refer to Figure K for Steps 13-14

Step 13: Using Steps 1-9, carefully re-install the bumper onto the vehicle and reconnect the turn signals.

Step 14: Your Takeda Dynamic Air Scoop is now installed, Thank you for choosing Takeda!

Pro DRY S Air Intake System



P/N: 56-70005D

Pro 5R Air Intake System



P/N: 56-70005R

SPRINT BOOSTER



P/N: 77-17001

Twisted Steel Down Pipe w/cat



P/N: 48-37001-HC

Track Series Air Intake System



P/N: 57-10006R

Pro 5R Intake System



P/N: 54-76305-CF

Takeda 3" to 2.5" Cat-Back Exhaust

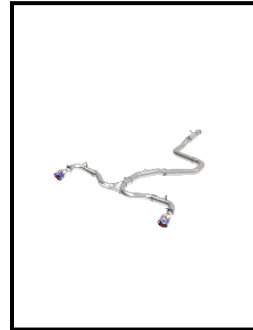

P/N: 46-20198-B

SCORCHER GT Power Module



P/N: 77-47001

Magnum Flow OE Replacement



P/N: 30-10323

To purchase any of the items above, view airflow charts, dyno graphs, photos, and video; please go to aFepower.com.



Page Left Intentionally Blank



Page Left Intentionally Blank



Page Left Intentionally Blank



Warranty

General Terms:

- aFe warrants their products to be free from manufacturer's defects due to workmanship and material.
- This warranty applies only to the original purchaser of the product and is non-transferrable.
- Proof of purchase of the aFe product is required for all warranty claims.
- Warranty is valid provided aFe instructions for installation and/or cleaning were properly followed.
- Proper maintenance with regular inspections of product is required to insure warranty coverage.
- Damage due to improper installation, abuse, unauthorized repair or alteration is not warranted.
- Incidental or consequential damages or cost, including installation and removal of part, incurred due to failure of aFe product is not covered under this warranty.
- All warranty is limited to the repair and/or replacement of the aFe part. To request Return Goods Authorization ("RGA"), email RGA@afepower.com or call (951)493-7100. Upon receipt of the RGA, you must return the product to the address provided in the RGA, freight prepaid and accompanied with a dated proof of purchase and the RGA. Upon receipt of the defective product and upon verification of proof of purchase, aFe will either repair or replace the defective product within a reasonable time, not to exceed thirty days.

Product Category	P/N Prefix	Warranty duration
Direct OE Replacement Filters	10, 11, 30, 31, 71, 73	Life of the vehicle
Racing Filters	18	1 year
Universal	20, 21, 23, 24, 72, TF	2 years
Air Intake Systems	50, 51, 53, 54, 55, 56, 57, 58, 75, TR, TA, TL, TM	2 years
Exhaust Systems	49	2 years
Intercoolers & Intercooler Tubes	46-2	2 years
Intake Manifolds	46-1	2 years
Differential Cover	46-7	Life of the vehicle
Exhaust Manifolds	46	2 years
Throttle Body Spacers	46-3	2 years
Turbochargers	46-6	2 years*
Fluid Filters	44	90 days
Pre-Filters	28	2 years
Heavy Duty OE Replacement	70	2 years
PowerSports OE Replacement	81, 87	2 years
PowerSports Intake Systems	85	2 years

No other warranty expressed or implied applies nor is any person or advanced FLOW engineering authorized to assume any other warranty. Some States do not allow the exclusion or limitation of incidental or consequential damages or do not allow limitations on how long an implied warranty lasts, so the above limitations or exclusions may not apply to you. This warranty gives you specific legal rights, and you may also have other rights which vary from State to State.

*See turbocharger warranty for more info

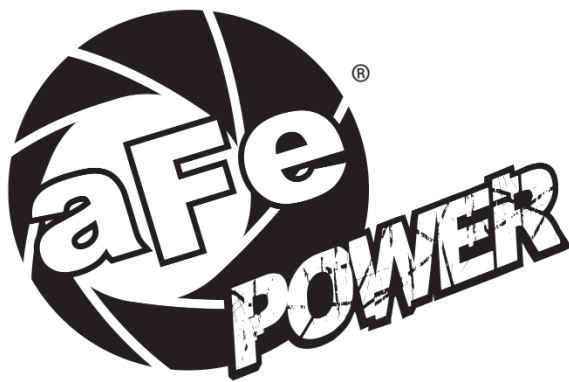

advanced FLOW engineering, inc.

252 Granite Street Corona, CA 92879
TEL: 951.493.7100 • TECH: 951.493.7185
E-Mail: Tech@aFepower.com