



INSTALLATION GUIDE: AWE EXHAUST SUITE FOR THE PORSCHE MACAN 2022+

For up-to-date fitment information, please visit the product page on [AWE-Tuning.com](https://www.awe-tuning.com).

THIS GUIDE IS INTENDED FOR THE FOLLOWING PART NUMBERS:

- 3015-42952 AWE Touring Edition Catback Exhaust for '22+ Porsche Macan 2.9TT - Chrome Silver Tips
- 3015-43952 AWE Touring Edition Catback Exhaust for '22+ Porsche Macan 2.9TT - Diamond Black Tips

Welcome to the AWE family, and congratulations on your purchase of the AWE Exhaust System for the Porsche Macan. Exquisite build quality and craftsmanship, coupled with industry leading performance, distinguish this exhaust system from all others.

*For up to the minute fitment information, be sure to visit the AWE website. As always, AWE Performance Specialists are standing by for any questions, [right here](#).

PARTS LIST (TOURING SYSTEMS)



Inspect **ALL** parts prior to disassembly of vehicle; If damaged or **MISSING**, please contact the place of purchase immediately.

Symbol	Part Number	Description	QTY
	RU	Macan X-Pipe Mid Section	1
	G15	Porsche Macan 22+ DS Axle tube	1
	G16	Porsche Macan 22+ PS Axle tube	1
	G17	Porsche Macan 22+ DS Touring section	1
	G18	Porsche Macan 22+ PS Touring section	1
A >>	180250	AWE 2.5" Band clamp, stainless	4
B >>	3910-11012	AWE 1/2" Split Collar Clamp Kit	1
C >>	3910-41010	Hardware Kit for Integrated Clamp Style Exhaust Tips - Quad	1
D >>	150004	SBS Valve Motor Simulator	1
E >>	98380A457	7/64" x 1" dowel	1
F >>	91287A137	Metric 18-8 SS Hex Head Cap Screw M6 Size	2
G >>	92148A180	Metric 18-8 Stainless STL Split Lock Washer M6 Screw Size	2
H >>	91116A150	Metric 18-8 SS Large-Diameter Flat Washer M6 Screw Size	2
I >>	180014	77mm Inlet, 114mm OD, Integrated clamp, Chrome Silver	4
I >>	180015	4.50" OD x 3.00" ID, Slash Cut, Diamond Black, AWE Logo, Inter-grated Clamp	4

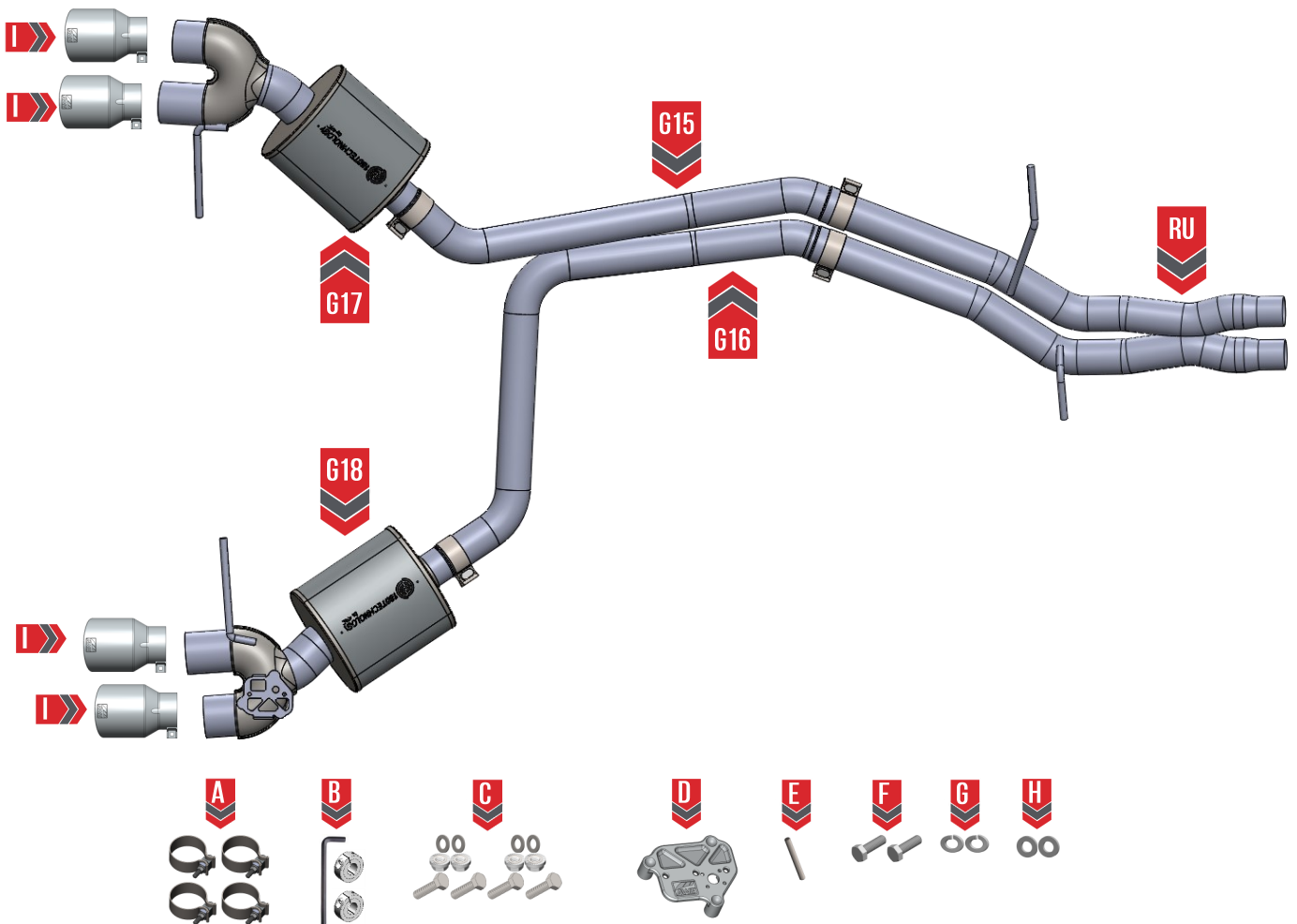



NOTE: Always refer to the manufacturer's service manual for precise torque specifications on all OEM fasteners.



CAUTION: The exhaust may be **VERY HOT** — allow adequate time for the system to cool down before disassembly. Severe burns and injury will occur if skin comes into contact with a hot exhaust system.

STEP 1

1. Remove the OE hardware holding the splash guard in place, shown at **(A)** in **Figure 1**. Then remove the splash guard.
2. Remove the two OE bolts on the bottom side of the bumper cover, shown at **(B)** in **Figure 1**.

Note: OE hardware will be reused.

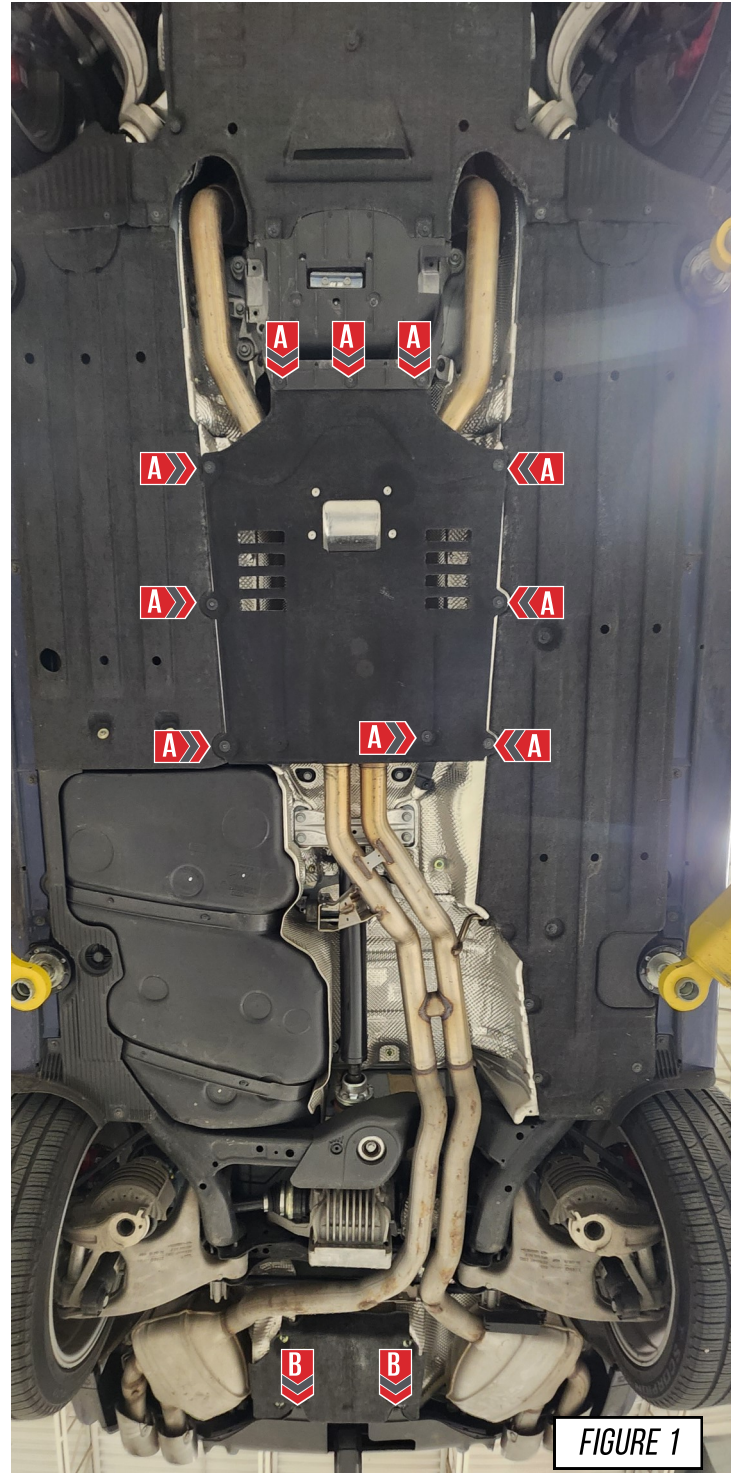

STEP 2

Continue by removing the OE dual exit exhaust by following the steps, shown in **Figure 2**.

Soak all bolts and rubber hangers in penetrating oil before starting any work.

Place a pole jack under the OE exhaust after the H-pipe.

1. Loosen the OE clamps, shown at (A) in **Figure 1**. Then slide the clamps towards the front of the car.
2. Unbolt the hangers from the chassis shown at (B) in **Figure 1**.
3. Unplug the valve motor harness on the passenger side exhaust tips as, shown at (C) in **Figure 1**.
4. Remove the OE rear hangers from under the bumper cover, as shown at (D) in **Figure 2**.
5. Remove the OE exhaust

Note: OE hangers, and hardware will be reused.

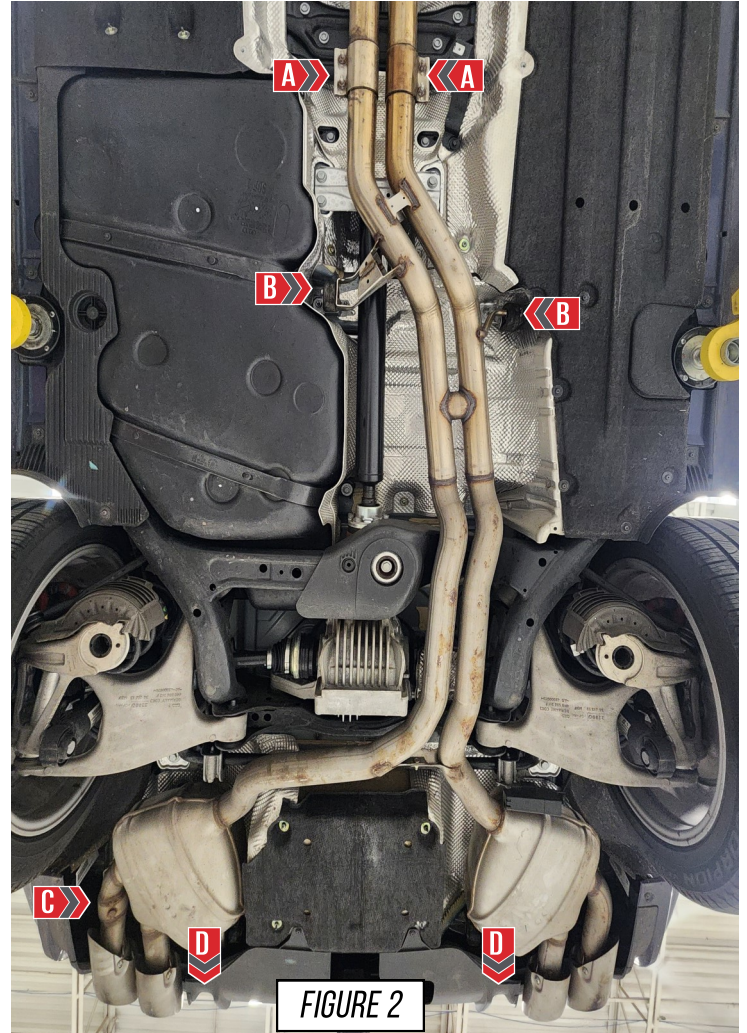

STEP 3

Remove the OE hangers from the OE H-pipe, as shown in **Figure 3-1**. Make sure to specify which hanger is driver side, and which is passenger side.

Reinstall the driver, and passenger side hangers on your AWE X-pipe section (**RU**), as shown in **Figure 3-2**. Note that the driver side hanger goes on the long hanger bar, and the passenger side hanger goes on the short hanger bar.

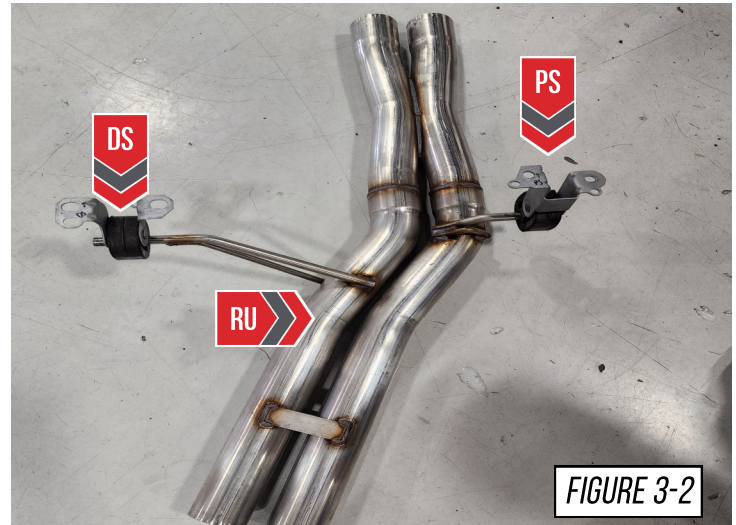
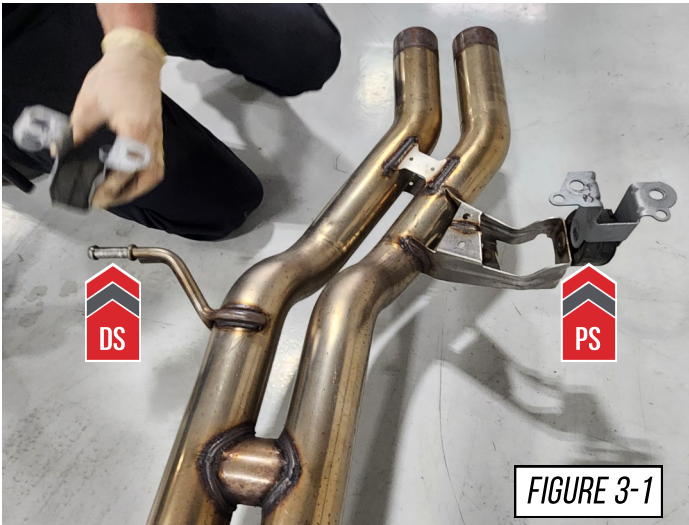

STEP 4

Install your AWE X-pipe (**RU**), as shown in **Figure 4**.

Do this by first reinstalling the OE hangers, as shown at (**A**), in **Figure 4**

Next, slide the OE clamps over the inlet side of your AWE X-pipe (**RU**), as shown at (**B**) in **Figure 4**. Fully tighten the clamps at this time.

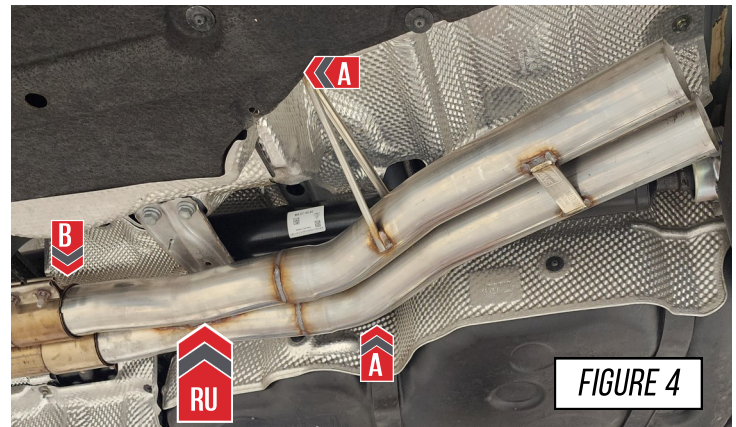

STEP 5

Now install your AWE passenger side axle tube (G16).

Do this by sliding a provided 2.5" clamp over the expanded inlet of the axle tube. Bottom out the expanded slip on the passenger side outlet of your AWE X-pipe (RU), as shown in **Figure 5**.

Rotate the axle tube so it sits behind the differential, as shown in **Figure 5**.

Snug the clamp but do not fully tighten it at this time.

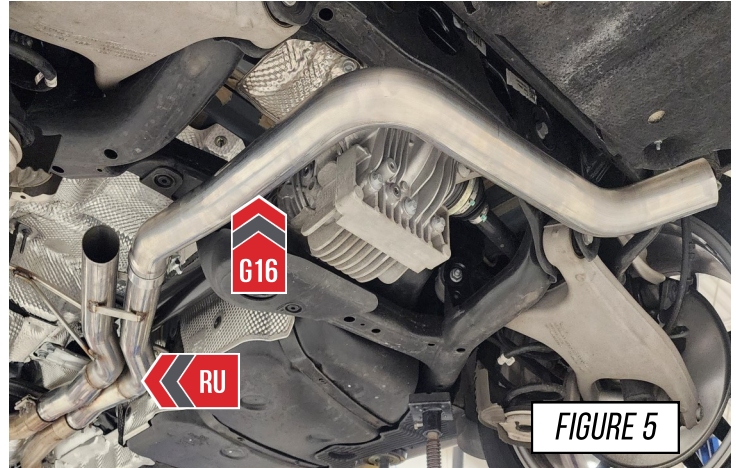

STEP 6

It is crucial to install each section and exhaust band clamps correctly to prevent loose joints, exhaust leaks and rattles.

Arrow A shows the expanded pipe and the preinstalled exhaust clamp being brought up to the corresponding pipe.

Arrow B shows the overlapping pipe installed correctly over the corresponding pipe.

Arrow C shows the exhaust band clamp being brought to the edge of the expanded pipe.



NOTES:

- **Do not** fully torque any exhaust clamp until the entire exhaust has been installed and adjusted.
- Torque specification is a **minimum** of 60 ft/lbs

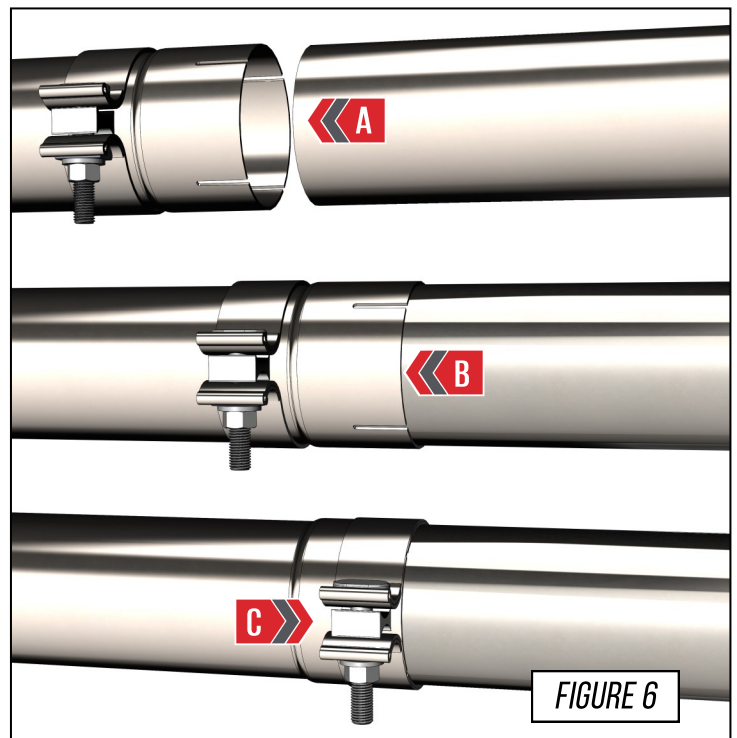

STEP 7

Next install your AWE passenger side axle tube (G15).

Do this by sliding a provided 2.5" clamp over the expanded inlet of the axle tube. Bottom out the expanded slip on the passenger side outlet of your AWE X-pipe (RU), as shown in **Figure 7**.

Rotate the axle tube so the outlet is pointed up towards the underbody of the car, as shown in **Figure 7**.

Snug the clamp but do not fully tighten it at this time.

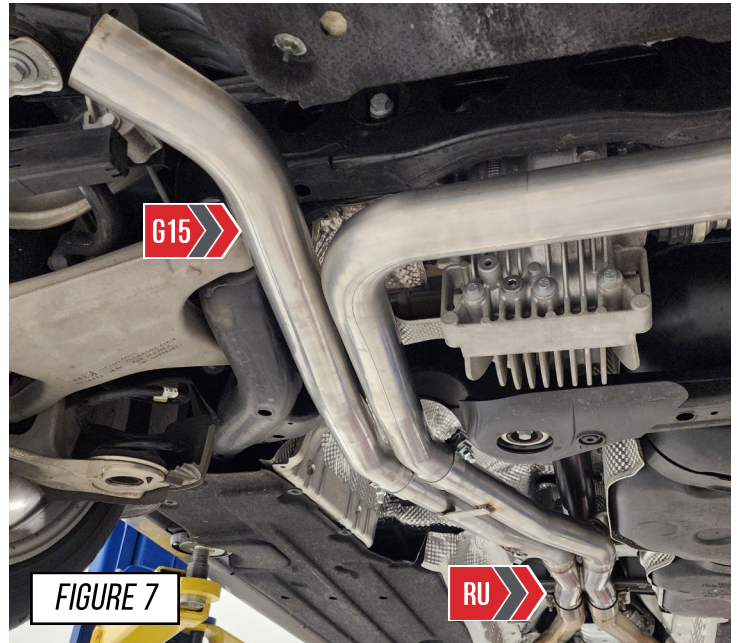

STEP 8

Remove the 2 rear most OE hangers.

It is important to note which hanger came from which side, as installing them on the wrong side will not allow correct fitment.

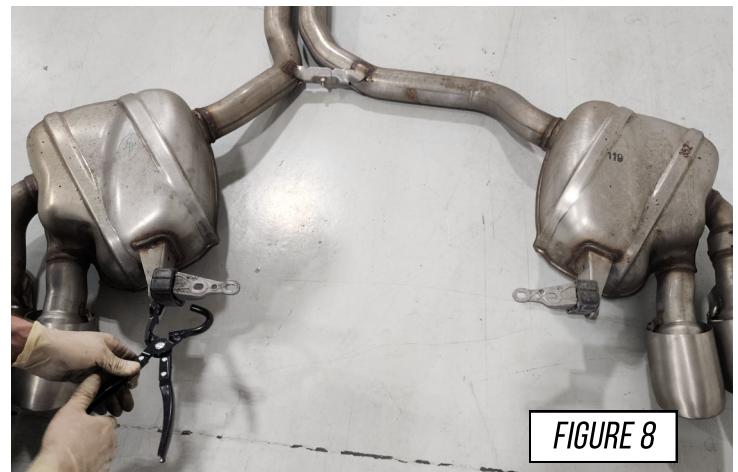

STEP 9

Next gather your AWE driver side touring section (**G17**), and install the OE driver side hanger that was removed earlier, onto the AWE hanger bar, as shown at (**A**) in **Figure 9**.

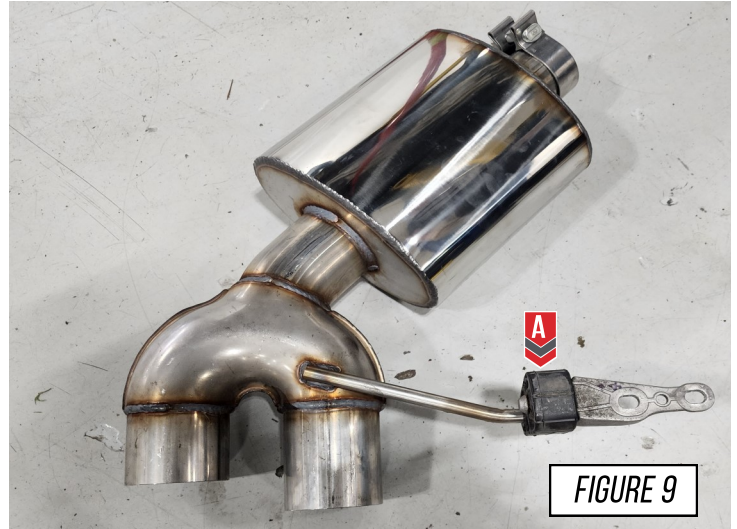

STEP 10

Install your AWE driver side touring section (**G17**), as shown in **Figure 10**.

First reinstall the OE hanger, using the OE hardware, as shown at (**A**).

Next slide a provided 2.5" clamp over the expanded end of the touring section.

Bottom out the slip joint on the outlet side of the AWE driver side axle tube (**G15**), as shown at (**B**).

Rotate the touring section so the tip outlets are in the center of the valance.

Sung the clamp down, but do not fully tighten it at this time.

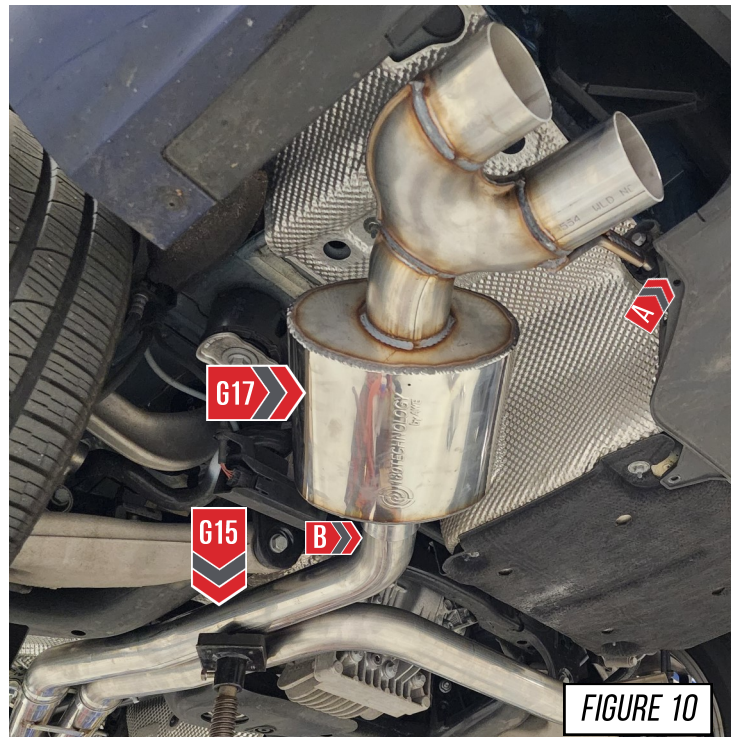

STEP 11

Remove the OE valves from the OE exhaust system.

Next gather your valve motor simulator (**A**) and your dowel pin (**B**). Place the dowel pin in the cut out on the bracket shown in **Figure 11**.

Secure the OE valve motor to the simulator bracket using the OE hardware, as shown in **Figure 11**.



STEP 12

To ensure you have the valve simulator aligned correctly, flip it over and verify that the dowel is resting in the cut out of the valve motor pin, as shown in **Figure 12**.

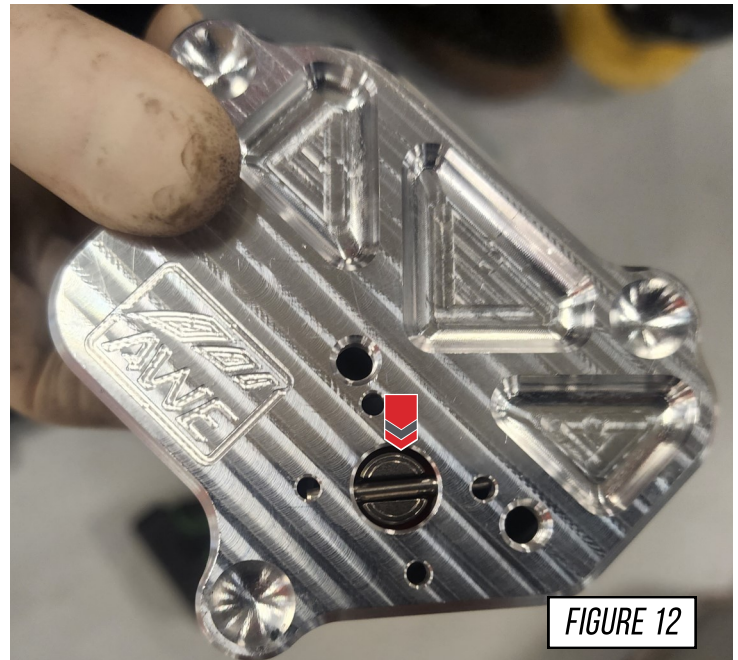

STEP 13

Install your valve simulator bracket onto the mounting bracket on your AWE passenger side touring section (**G18**), as shown in **Figure 13**

Line up the two outer threaded holes on the valve bracket simulator with the holes on the mounting plate.

Using the provided hardware, as shown at (**A**) tighten the valve simulator bracket onto the mounting bracket.

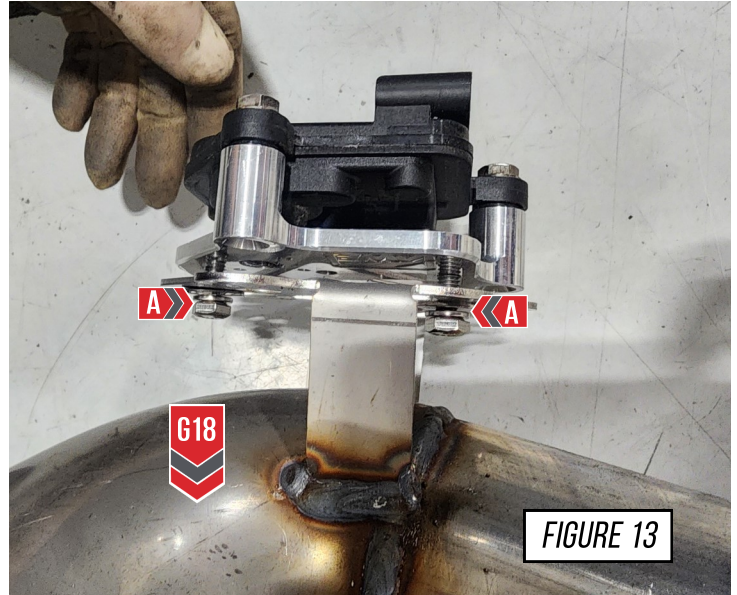

STEP 14

Next gather your AWE passenger side touring section (**G18**), and install the OE passenger side hanger that was removed earlier, on to the AWE hanger bar, as shown at (**A**) in **Figure 14**.

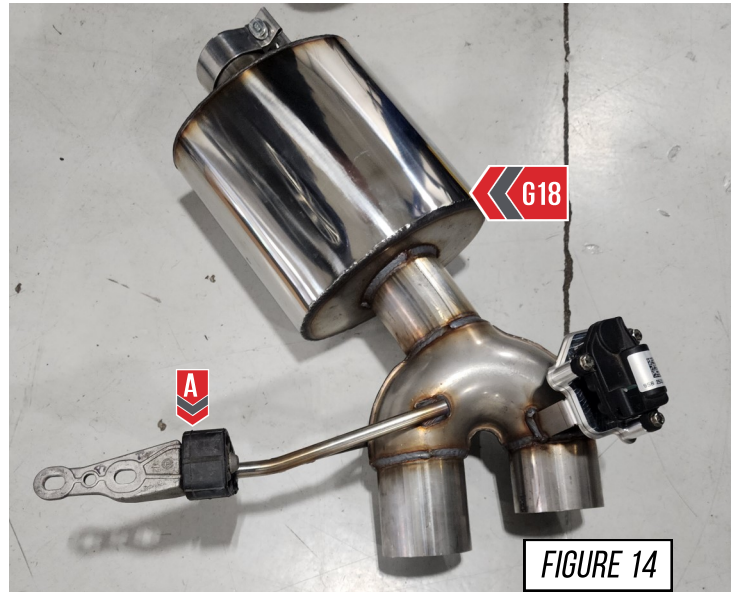

STEP 15

Install your AWE passenger side touring section (**G18**), as shown in **Figure 15**.

First reinstall the OE hanger, using the OE hardware, as shown at (**A**).

Next slide a provided 2.5" clamp over the expanded end of the touring section.

Bottom out the slip joint on the outlet side of the AWE driver side axle tube (**G16**), as shown at (**B**).

Rotate the touring section so the tip outlets are in the center of the valance.

Sung the clamp down, but do not fully tighten it at this time.

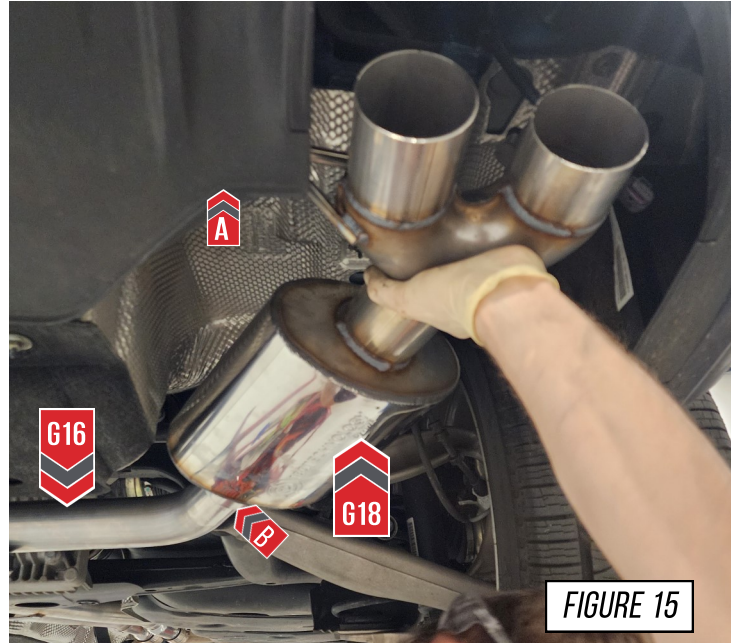

FIGURE 15

STEP 16

Plug the OE valve harness into the valve simulator assembly, as shown at (**A**), in **Figure 16**.

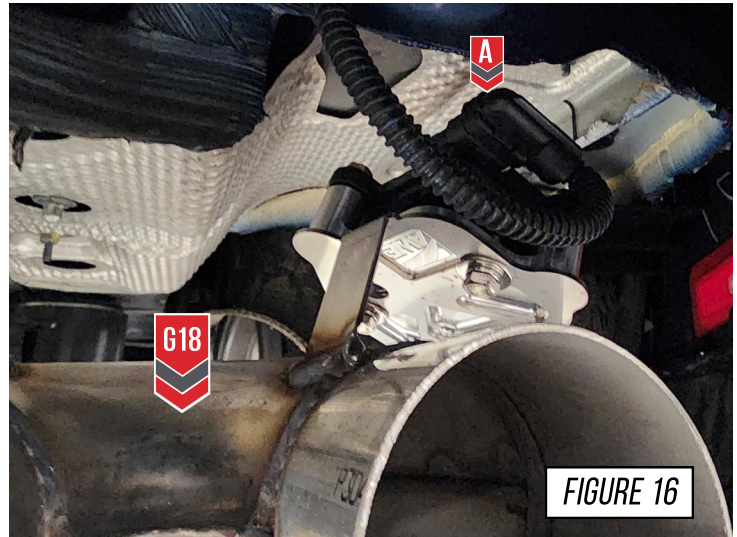



FIGURE 16

STEP 17

To install the exhaust tips with integrated clamps, first, attach the exhaust tip in the proper orientation onto the exhaust outlet tube.

Insert one of the carriage bolts from the hardware kit (**3910-41010**) through the tab on the exhaust tip and thread on one of the corresponding nuts.

Using anti-seize on the bolt threads will help installation and prevent breakage of hardware.

 If exhaust system only has 2 exhaust tips while the integrated clamp kit has enough hardware for our 4 tip exhaust systems. You will have 2 sets of hardware left over that will not be used.

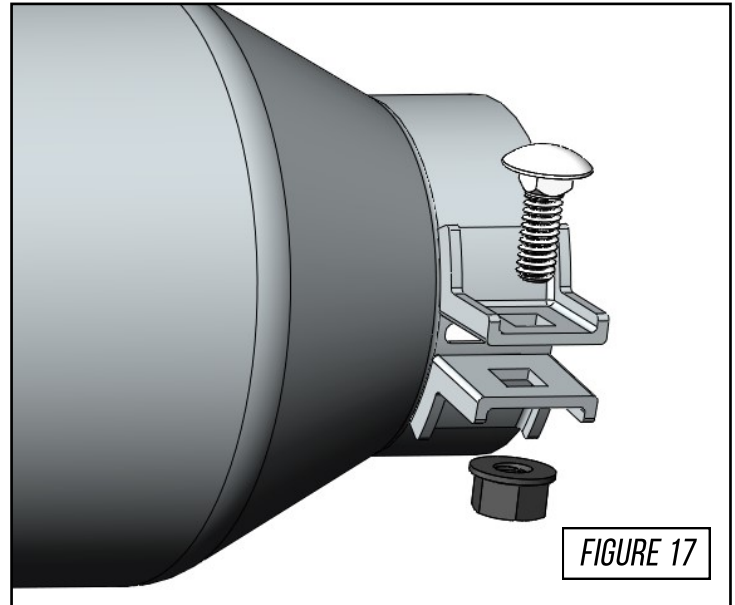

STEP 18

After your tips are in their desired position, install your AWE lock collar clamps.

Slide a provided lock collar onto the passenger side rear most hanger bar, as shown in **Figure 18-1**. Place the lock collar so it is touching the rubber hanger, and tighten it fully.

Next slide the other provided lock collar onto the driver side rear most hanger bar, as shown in **Figure 18-2**. Place the lock collar so it is touching the rubber hanger, and tighten it fully.

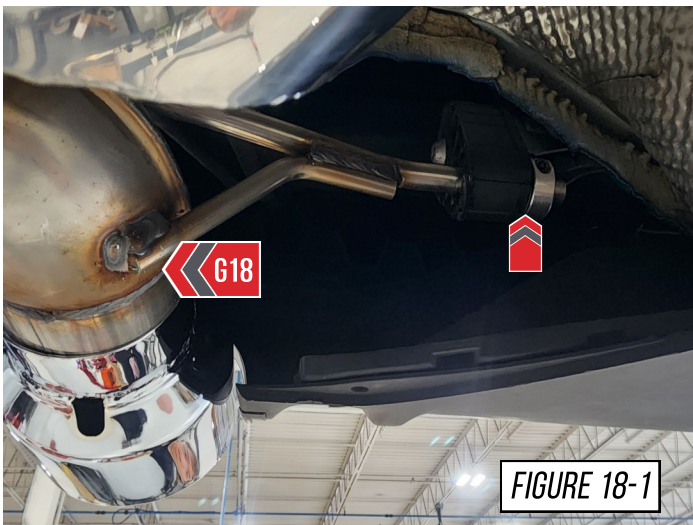

STEP 19

Reinstall the OE splash guard removed in **Step 1**, as shown in **Figure 19-1**.

Now reinstall the 2 screws that were removed from the rear bumper cover, as shown in **Figure 19-2**.

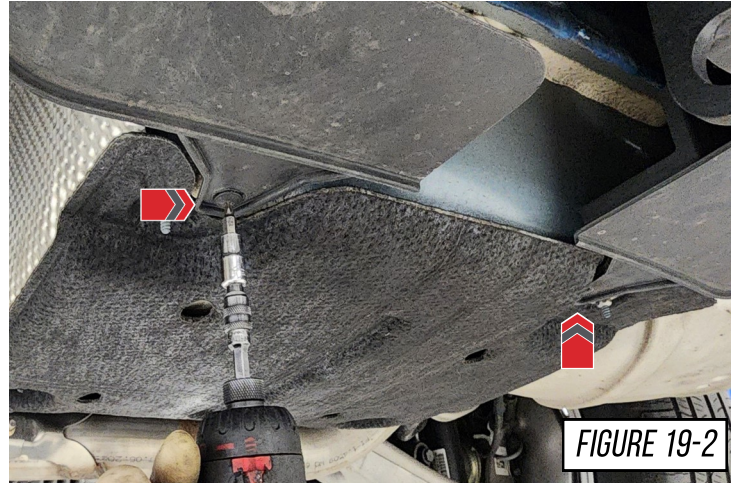
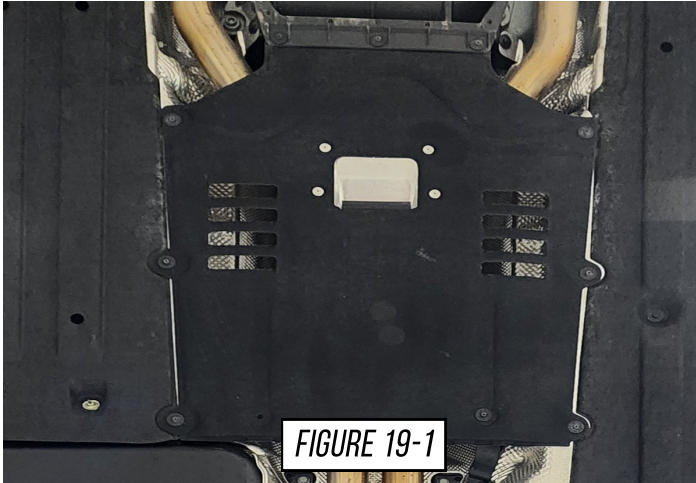

STEP 20

Make your final adjustments to the tips to ensure they are in a position you like. Once the desired positioning is achieved work from the front of the car to the back, tightening all the clamps fully and ensuring there is proper clearance of the chassis, and braces.

It is now recommended to drive the car to allow the exhaust to heat cycle after all clamps and tips are fully tightened.

 At this point the exhaust will be **very hot**, allow to cool before work continues.

Check the tips for correct alignment, adjust as needed.

 Don't forget to see the next page for any troubleshooting needs!



ENJOY!



TROUBLESHOOTING

Issue	Solution
Exhaust is not fitting correctly	Most fitment issues are due to improperly adjusted exhaust. This includes tip fitments and rattling due to chassis contact. Check out our FAQ/ fitment guide for more installation tips.
Incorrect or missing parts	Double check the parts list for your system and compare them with what you received. Fill out our contact form, found below and let us know what parts you need.

CARE

Once installed properly, your AWE exhaust will provide years of trouble-free performance.

The exhaust volume and sound will settle with usage; 800-1000 miles is required to break-in new exhaust systems.

Also, please note that the rear **180Technology**® resonator has a small drain hole to allow condensation to escape. Water drops from this area are normal.

Periodic cleaning of exhaust tips is necessary to maintain proper finish, especially in areas prone to road salt and caustic deicing solutions. Use a mild soap and water solution or car wax to clean the finish. Avoid using abrasive polishes, as they can scratch the finish. For best results, we recommend [AWE's Fantastic Tip Tonic](#).

Any questions or comments,
please do not hesitate to contact us:

AWE
[CONTACT FORM](#)

WARRANTY

Up-to-date warranty information is found [HERE](#).