

#TL000037



LOW PRESSURE FUEL PUMP/  
INSTALLATION INSTRUCTIONS

**APR**

---

---

---

---

Notes:

These instructions were written for a MkVI VW GTI, but other models (Audi A3, VW Beetle, VW Jetta) are similar.

When disassembling the car, be sure to keep all fasteners so they can be reused. It is recommend that you get some kind of compartmented tray to organize the fastners, such as a fishing tackle box or several large ice cube trays. Fasteners that are not reused for reinstallation are noted in the instructions.

These instructions assume that you have basic mechanical skills and several varieties of the tools listed in order to install the kit. If you have any questions about the install, feel free to contact your APR representative.



1) Support the car on jack stands or a lift. Open the hatch the vehicle. Open the hood and disconnect the two 10mm battery terminals. Remove the 13mm battery hold down bolt and remove the battery from the car. Remove the three 10mm battery bolts from the battery tray and remove the tray from the car.

2) Golf R ONLY - Raise the carpeted floor from the hatch area and remove the styrofoam spacer from the right side of the trunk. Remove the three 10mm bolts from the access panel, and replace with the three longer, supplied 10mm bolts (20mm long) and fender washers. Reinstall the styrofoam and put the carpet back in place.

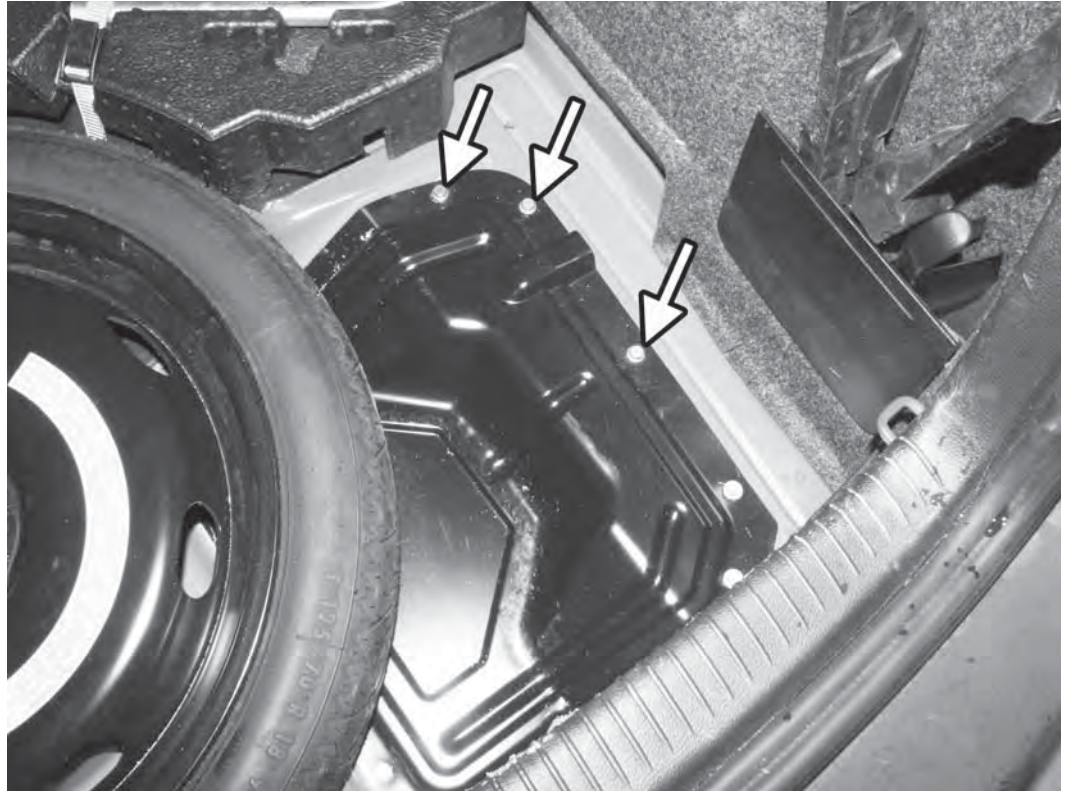

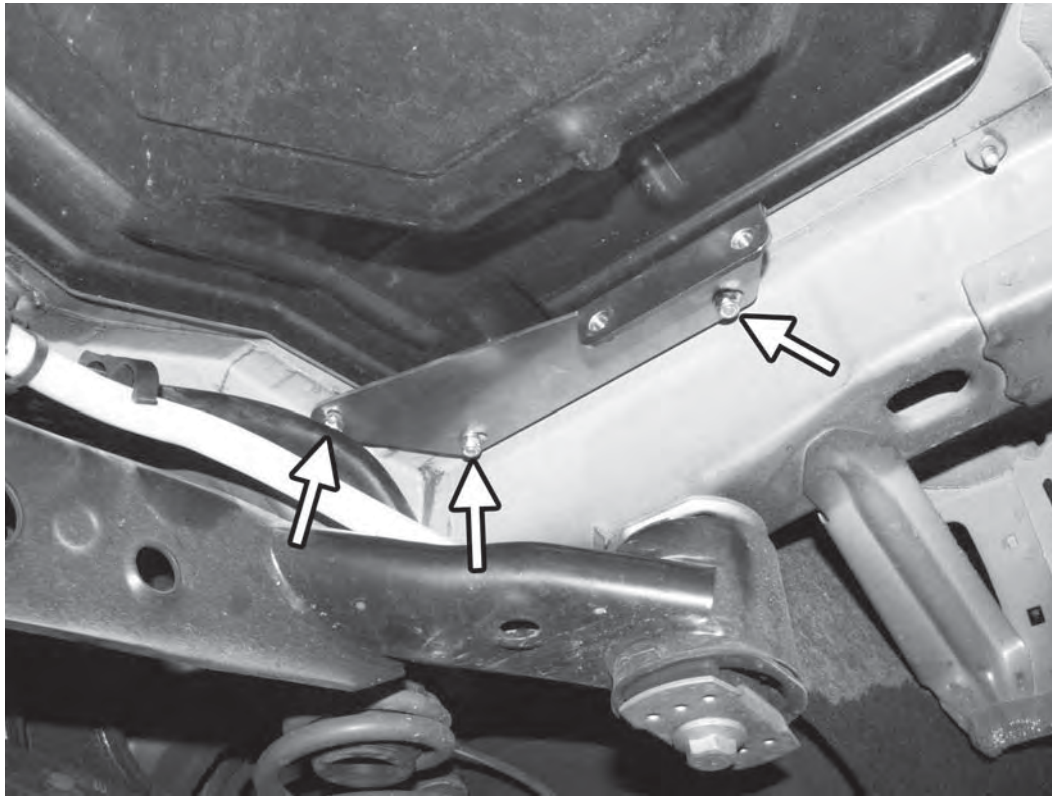

3) Golf R ONLY - From underneath the car, install the APR pump mounting bracket to the previously installed longer bolts with the supplied washers and three 10mm nylon locking nuts.

4) Install the foam insulating sleeve over the outside of the APR pump. Install the two bundy fittings with the supplied crush washers in the fuel pump and secure with a 14mm and a 16mm wrench.

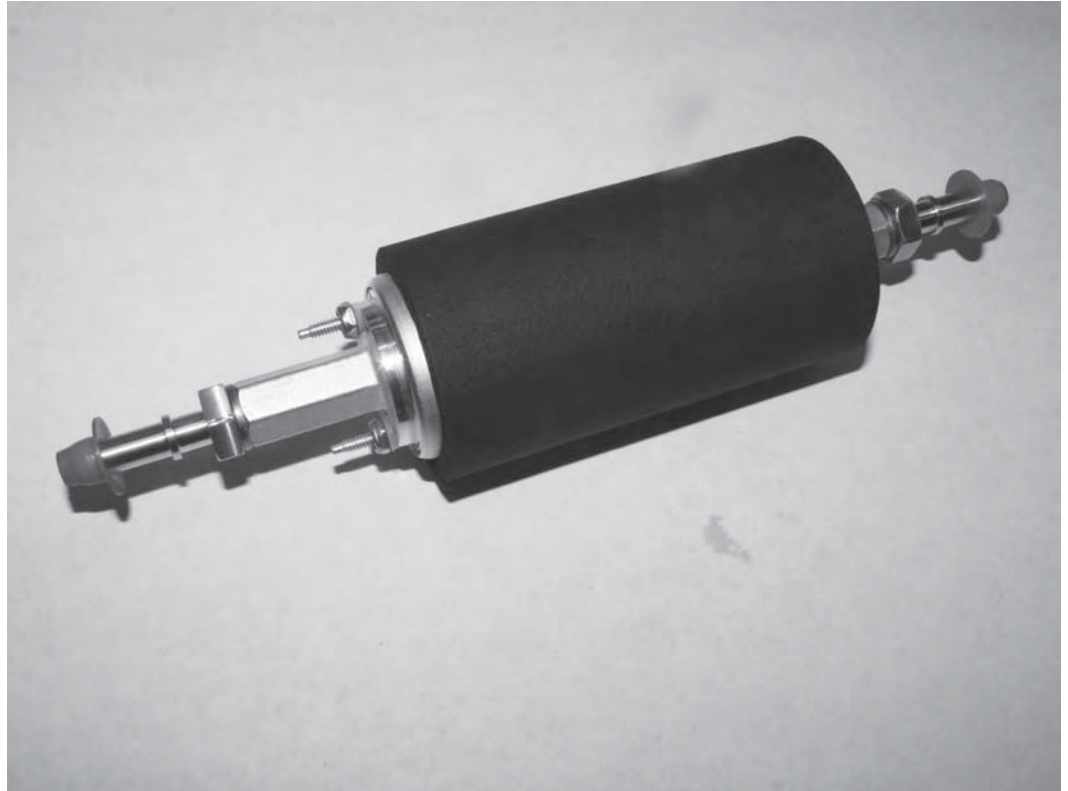

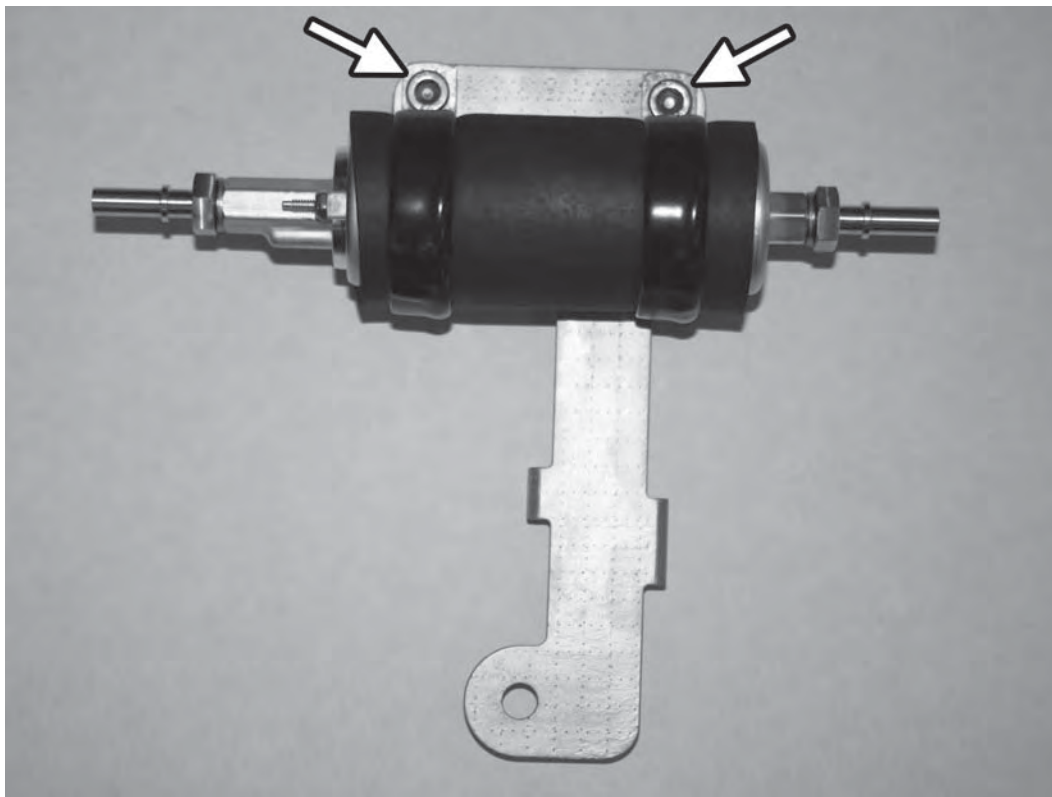

5) Mount the APR pump to the supplied APR pump bracket with the supplied APR pump bracket with the two 6mm allen screws as shown. For the Golf R, the bracket is already installed in the car. Mount the Golf R pump with the electrical connections facing the front of the car.



6) If installed, remove the two 10mm plastic nuts from the rear belly pan, and remove the belly pan from the car.

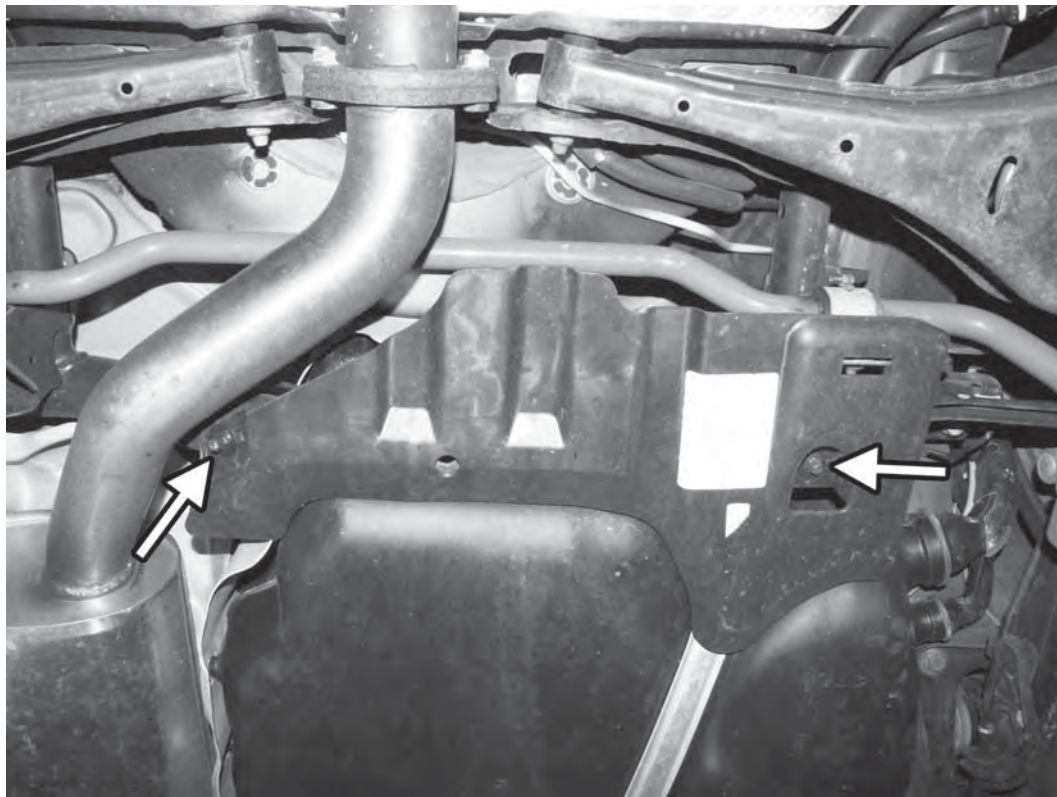

**APR, LLC**

4800 US HWY 280 West Opelika Alabama 36801

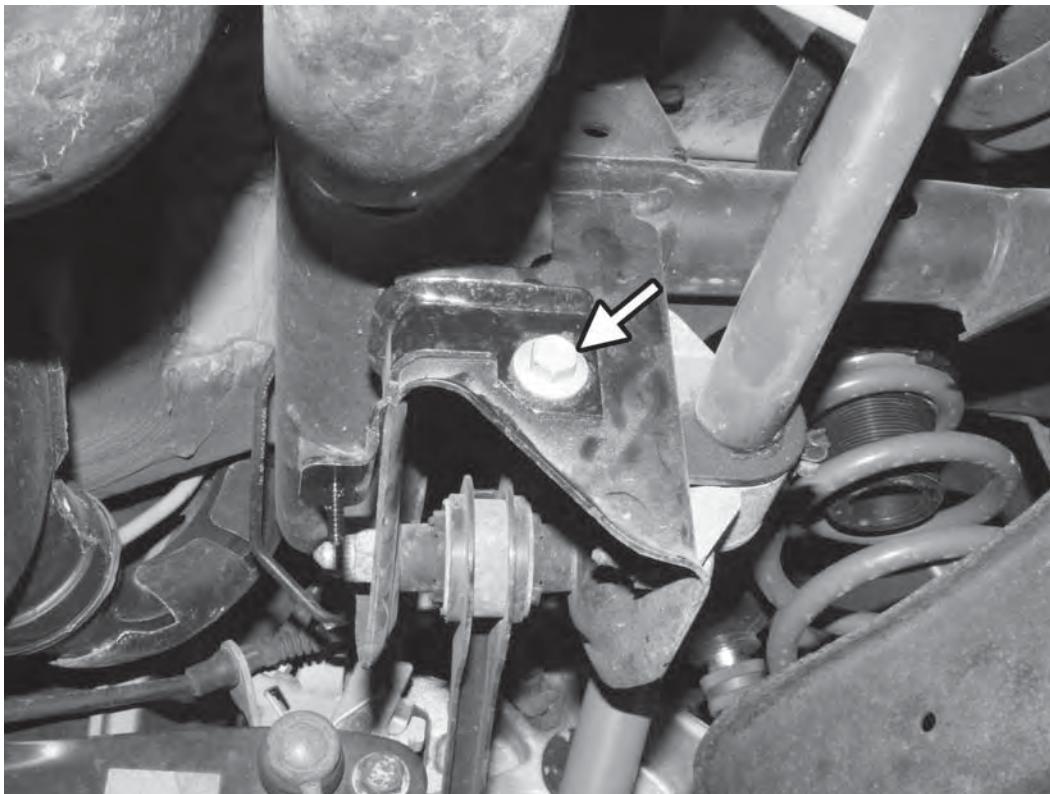

7) If installed, remove the 13mm bolt and nut that held the rear lower belly pan mount.

8) Install the APR pump and mounting bracket in the car with the supplied M8 allen bolt, with a washer and nylon locking nut on the back side. If equipped, be sure to install the bracket for the rear lower belly pan over the APR pump bracket. It may be necessary to reposition the APR pump on the mounting bracket, depending on your vehicle.

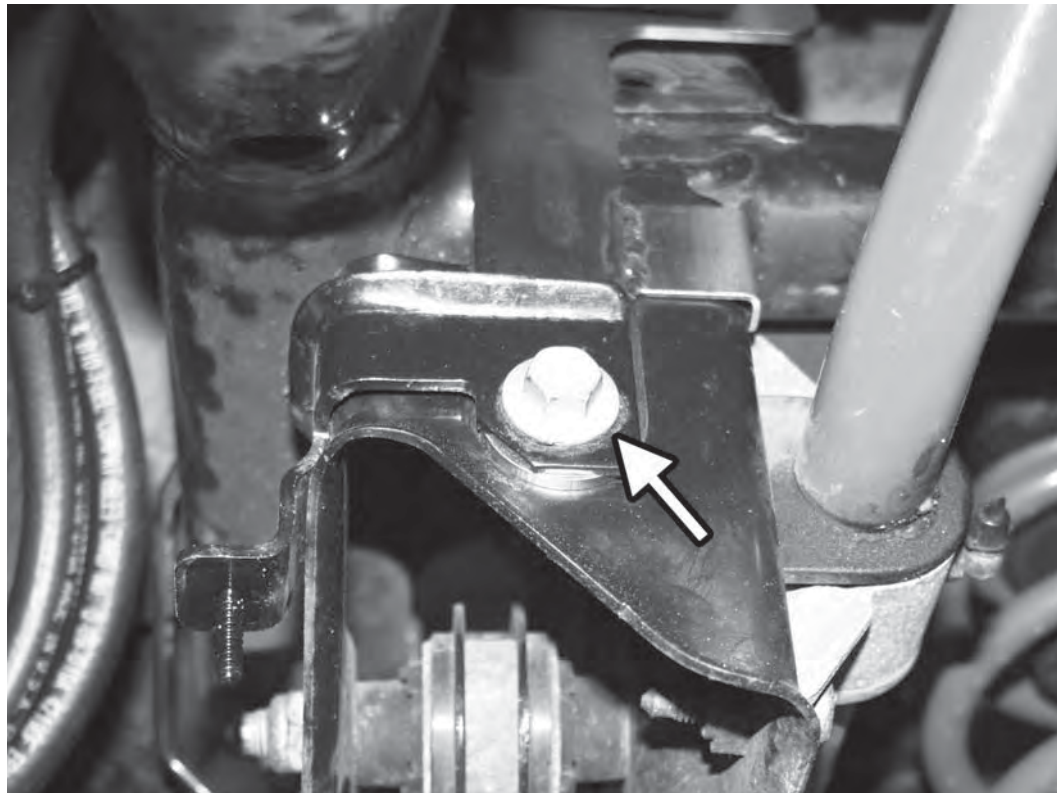

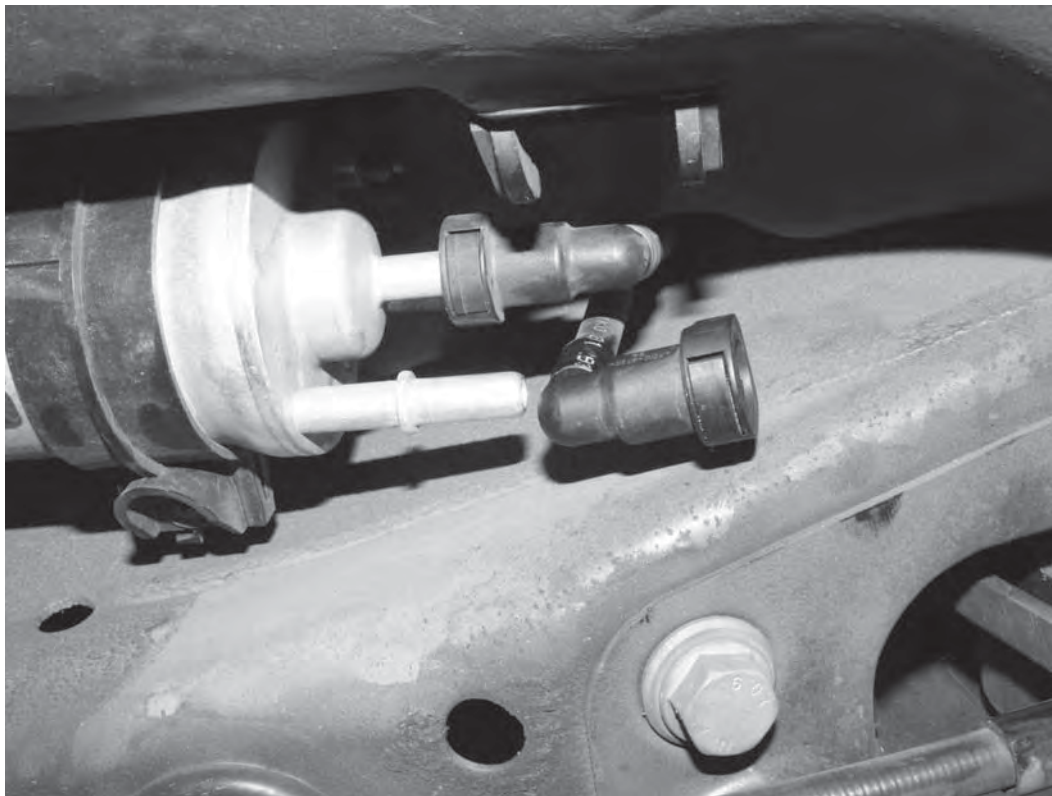

9) From the rear of the factory fuel filter, disconnect the fitting from the fuel feed line (marked on the filter "IN"). Gently twist the plastic connection 180° so it faces the rear of the car.

10) Install the one male bundy to barbed fitting into one end of the supplied fuel hose. Do not push the barbed side of the fitting too far into the hose - make sure the hose does not prevent the bundy fitting from being connected. Secure with a crimp clamp.

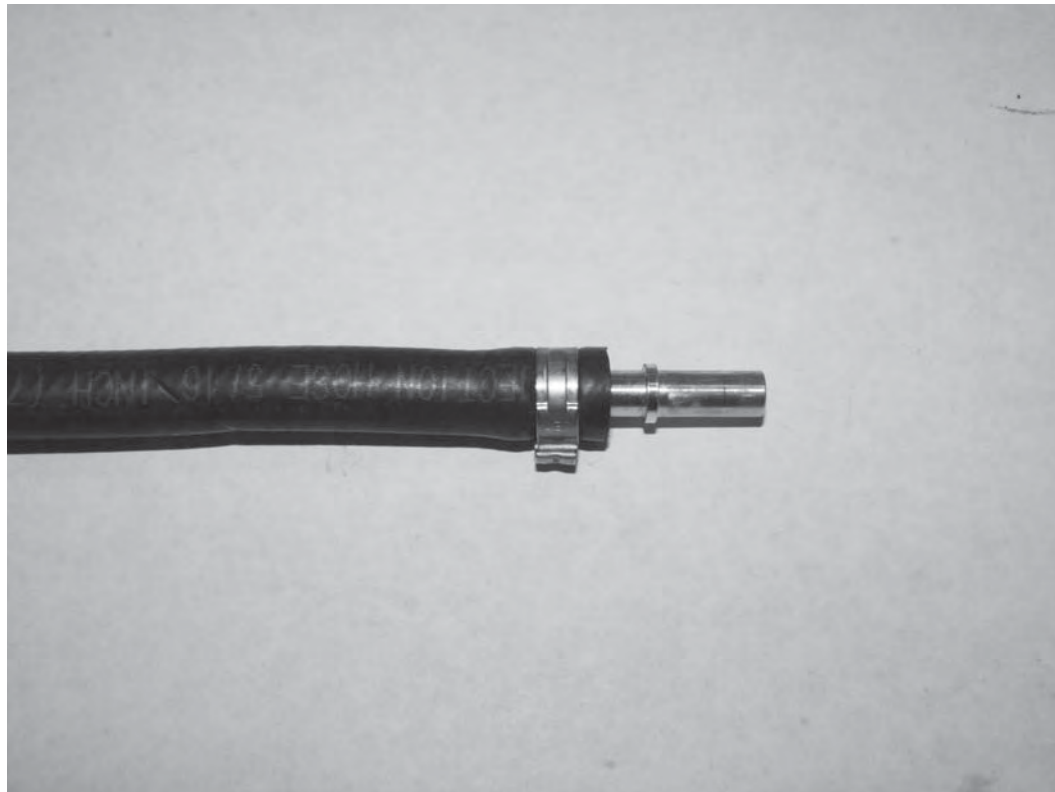

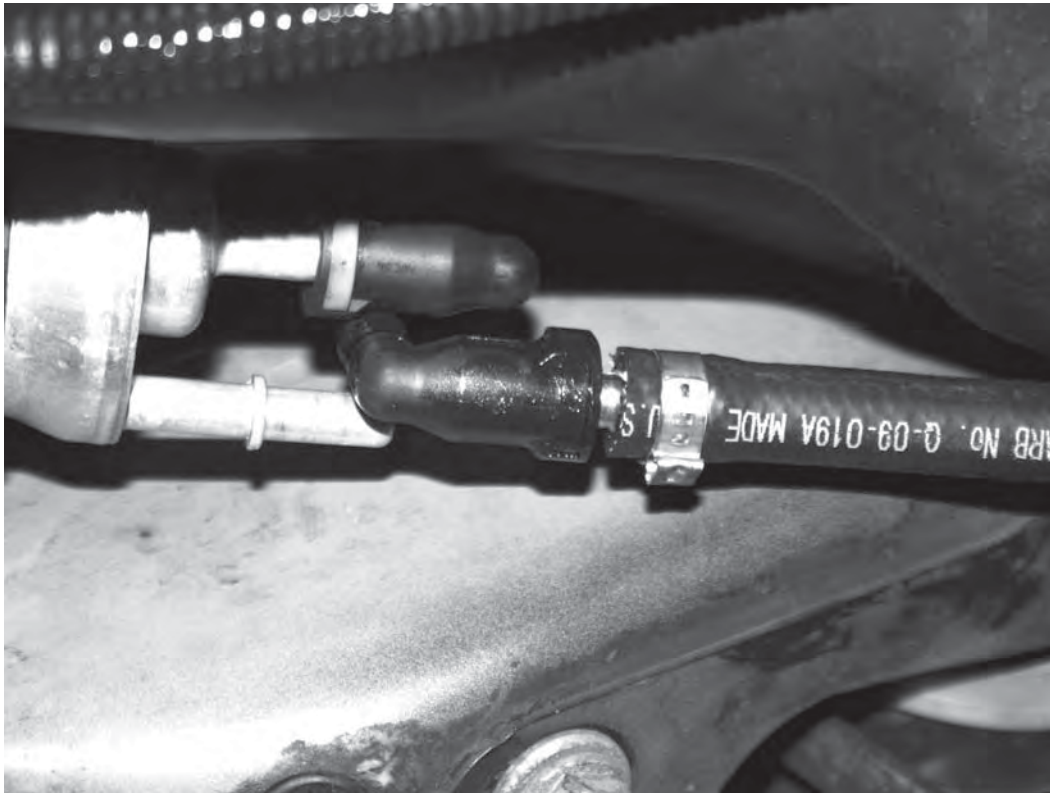

11) Connect the male side of the Bundy fitting to the rotated female connection at the fuel filter. Route the fuel hose over the subframe, being sure to go above all suspension components and the axles.

12) With the fuel hose routed, cut the hose to length. Install the supplied female 90° Bundy fitting in the hose, and secure with a crimp clamp. Connect the hose to the rear port of the APR pump.

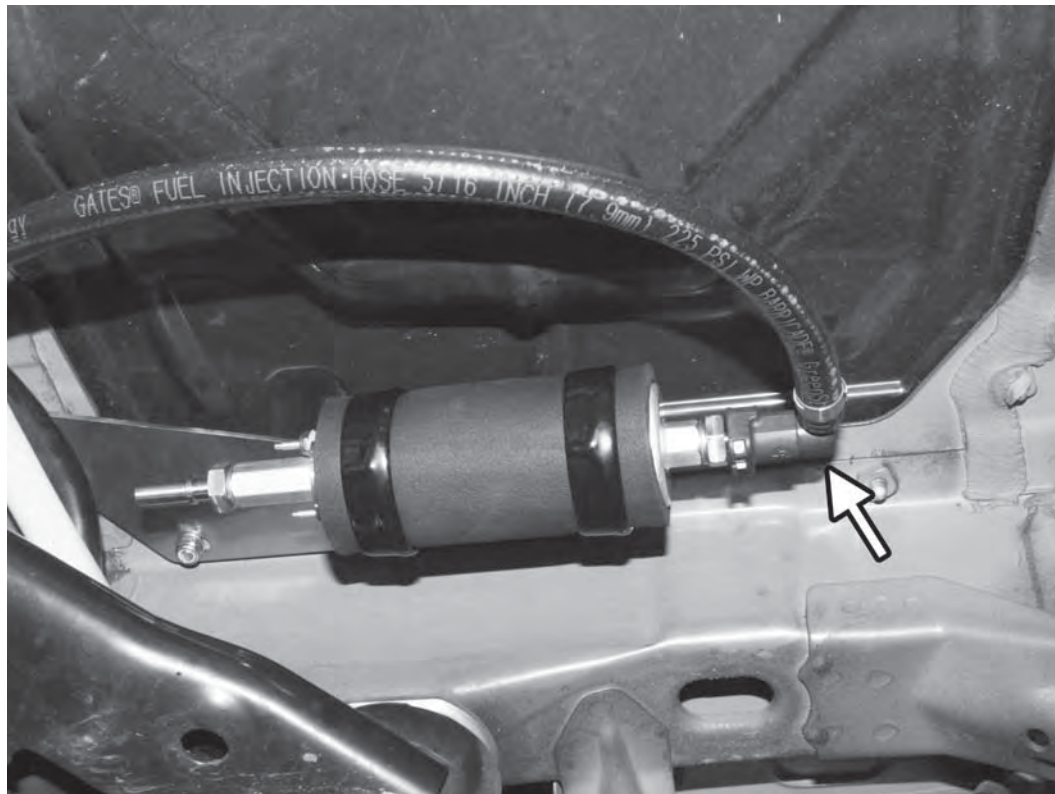

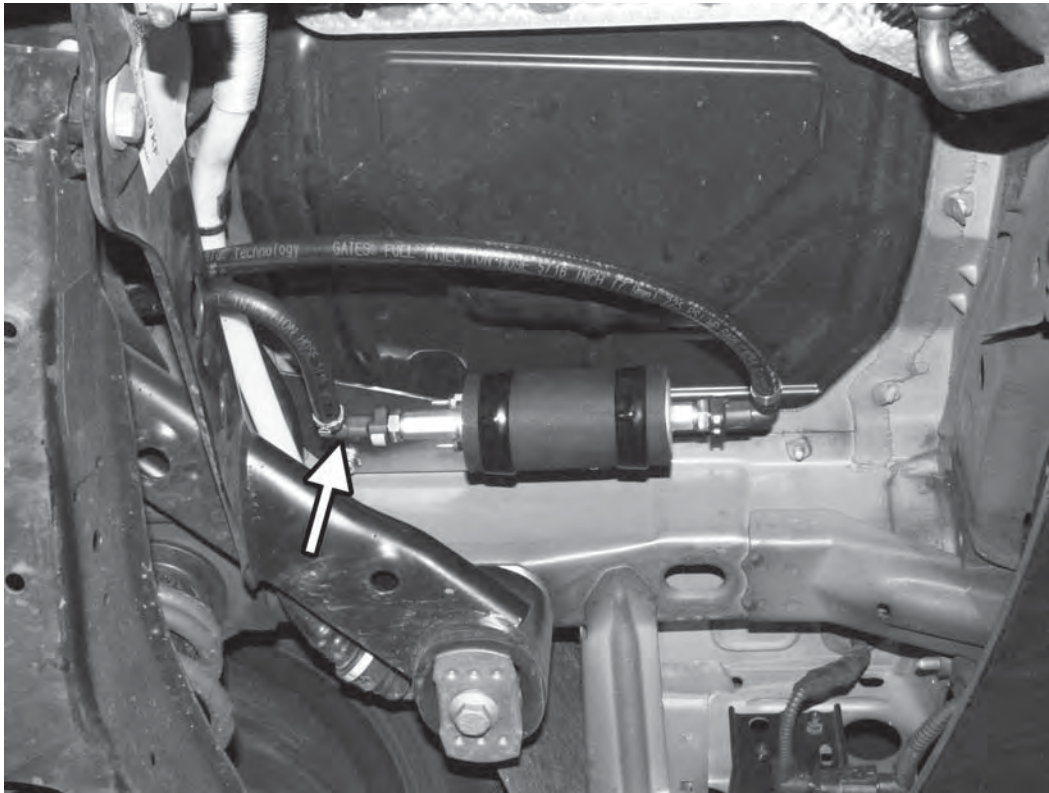

13) Install the other female 90° bundy fitting to the remaining hose, and secure with a crimp clamp. Connect the fitting to the front port of the APR pump, and route the fuel line back to the fuel filter, following the previously installed fuel hose.



14) With the fuel hose routed back to the fuel filter, cut the hose to length. Install the supplied female straight Bundy fitting in the hose, and secure with a crimp clamp. Connect the hose to the rear port of the fuel filter.

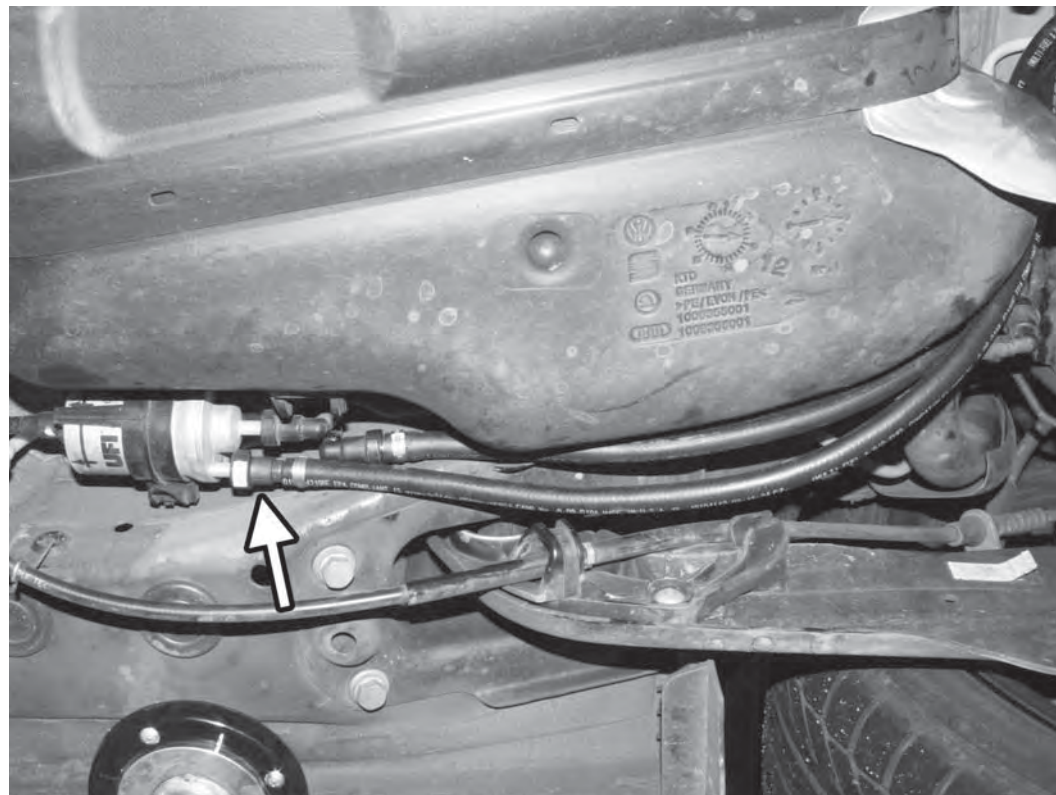

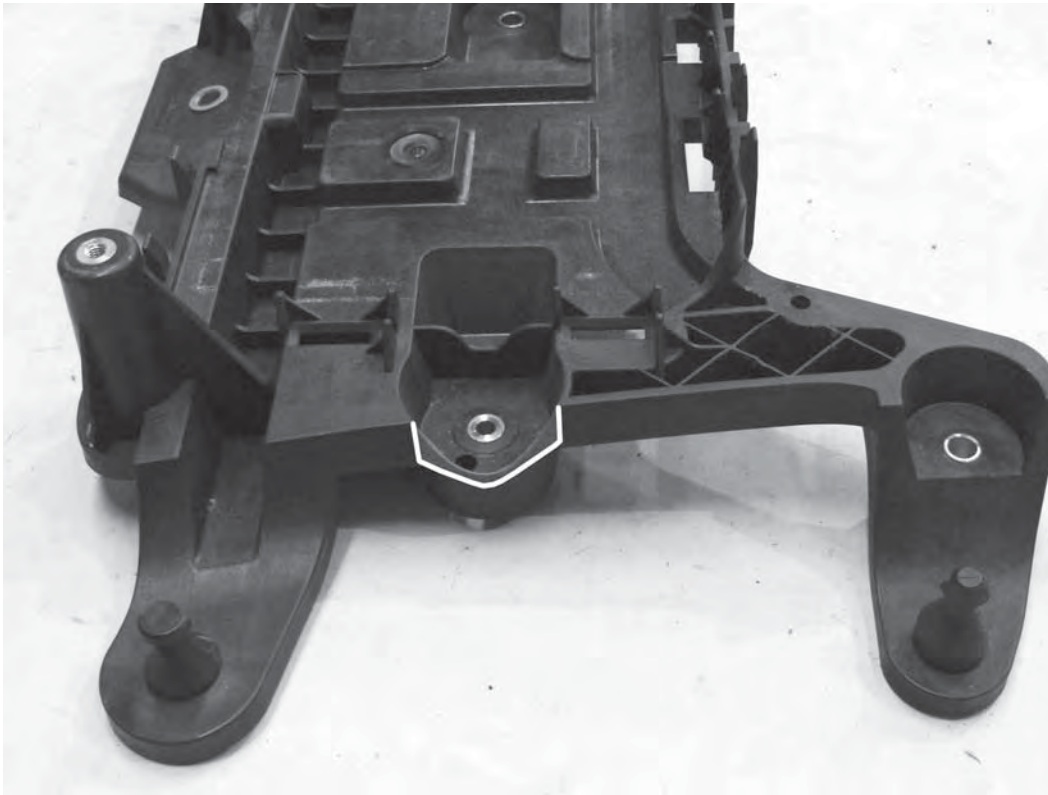

15) As seen removed from the car, trim the lip from the front of the factory battery box near the center mounting hole.

16) Install the APR CAN controller mounting bracket to the battery box, reusing the two 10mm factory bolts.

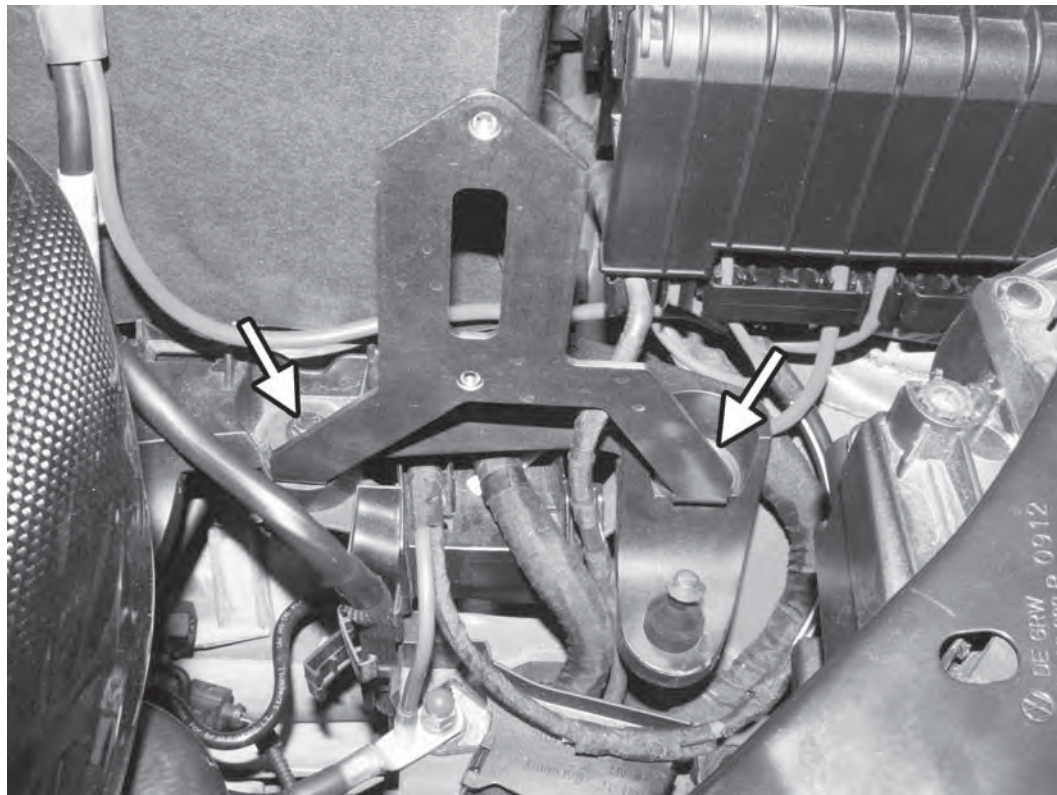

**APR, LLC**

4800 US HWY 280 West Opelika Alabama 36801

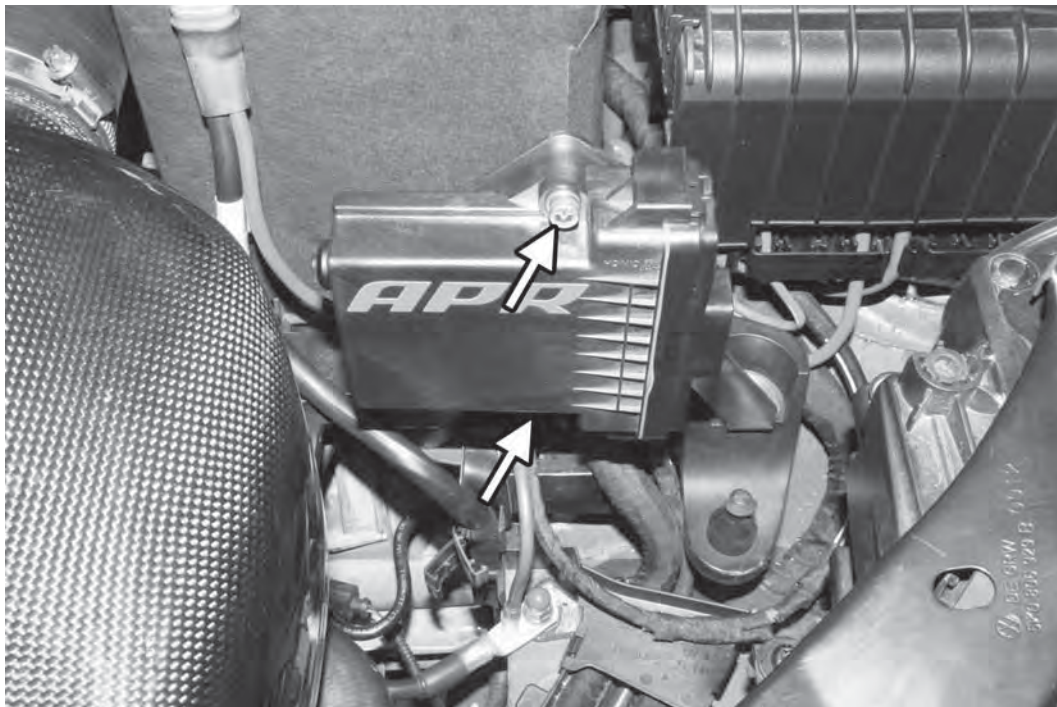

17) Mount the APR CAN controller to the APR bracket with the two supplied 5mm allen screws and washers.

18) Connect the APR wiring harness to the CAN controller, and secure with the attached 1/4" screw.

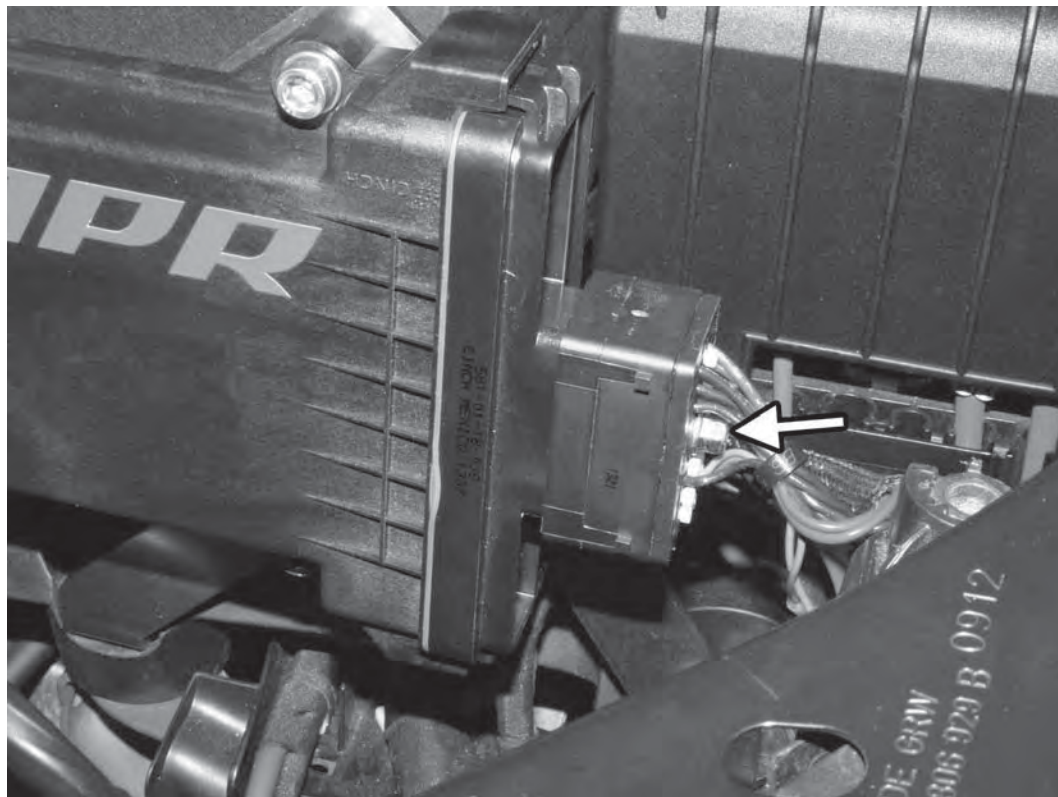

**APR, LLC**

4800 US HWY 280 West Opelika Alabama 36801

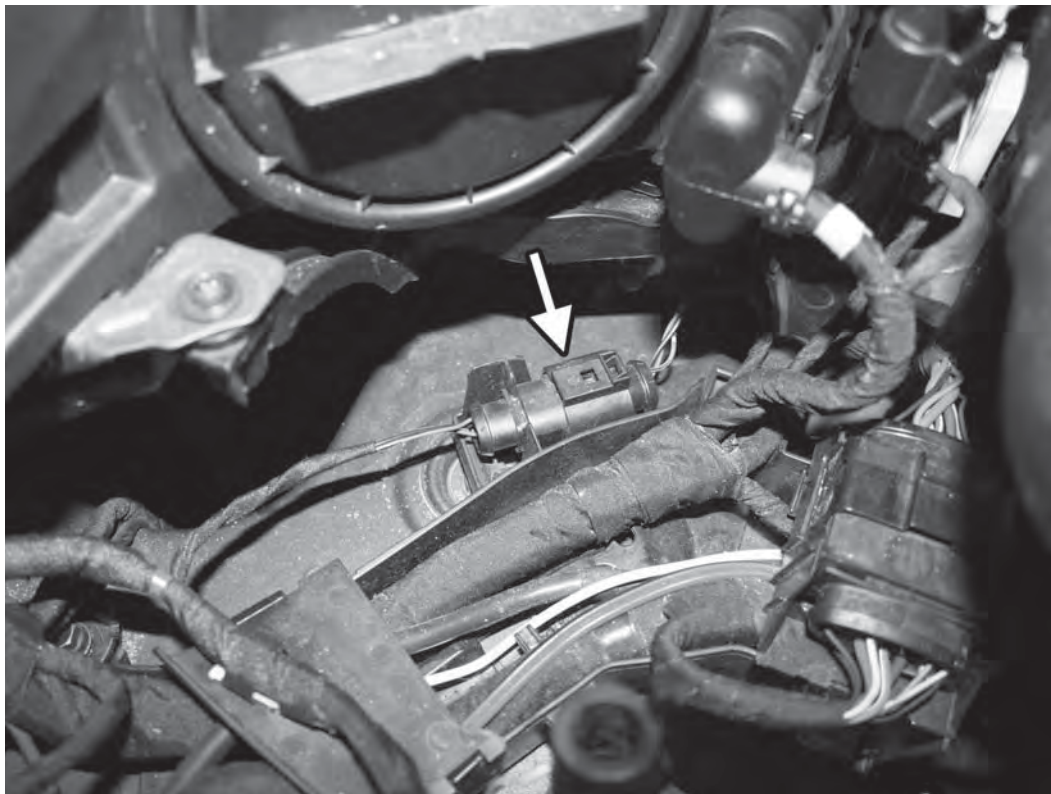

19) Disconnect the six pin connector that is located on the top of the frame rail, under the left headlight. The connectors from the APR CAN controller “splice” into this connector. Simply plug the harness from the CAN Controller into either side of the factory connector.

20) Connect the black wire from the CAN controller to any chassis ground. Some ground points are on the side of the frame rail, and some are on top of the frame rail. Trim the black wire CAN controller to length, and then install the supplied ring terminal to the wire and connect to the chassis ground. Once crimped, evenly heat the terminal with a small butane torch or other adequate heat source to seal the shrink wrap.

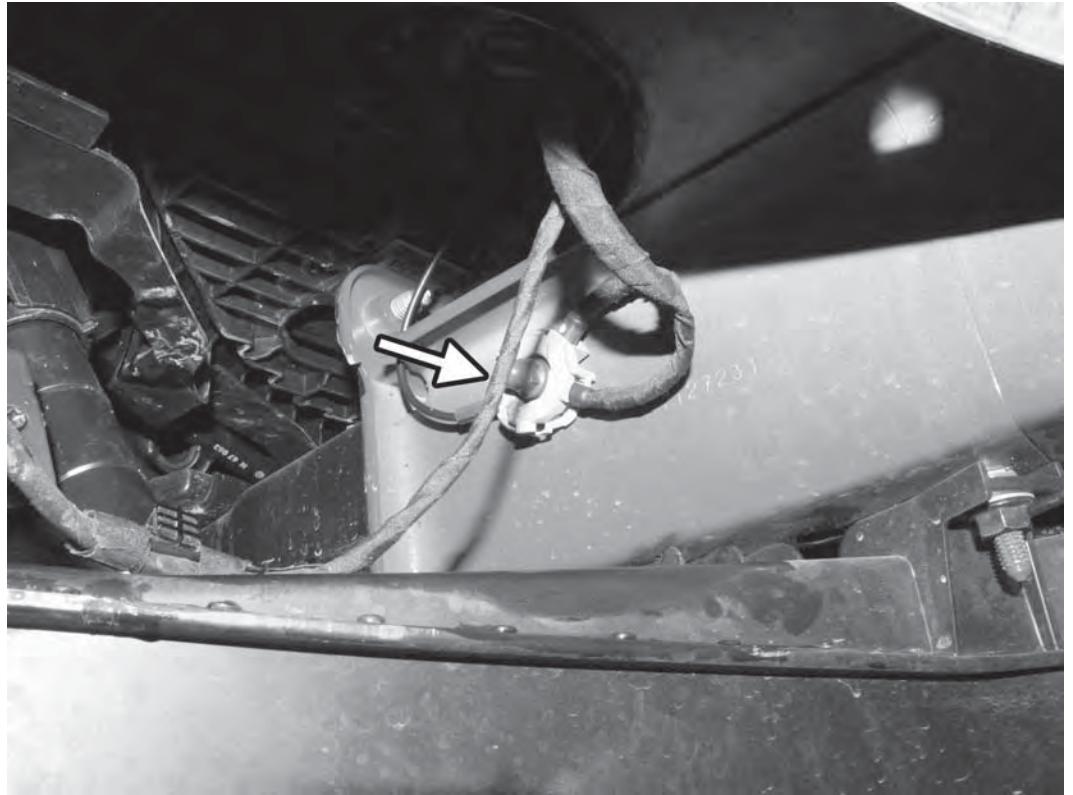

# GTI

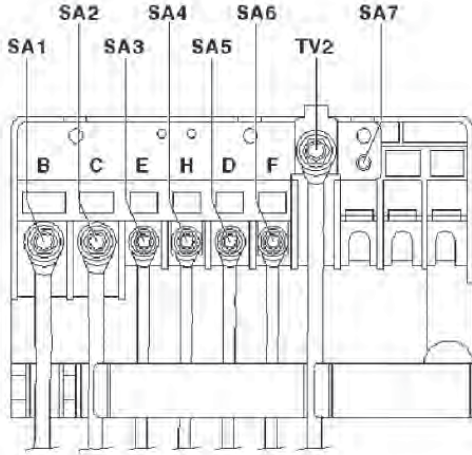

Style A

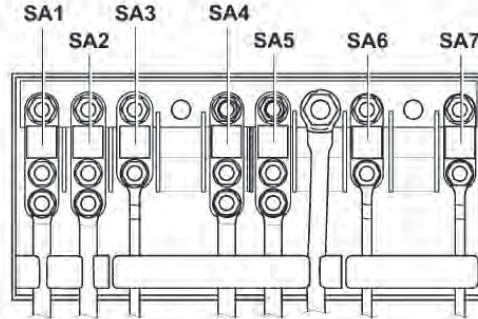

Style B

21) Connect the fused wire from the wiring harness to the appropriate location on the underhood fuse panel. Use the diagrams on the next two pages as a reference.

For GTI's, connect the wire to SA7. There are two different styles of fuse panels in GTI's, and one might require an included M5 nut.



22) Connect the fused wire from the wiring harness to the appropriate location on the underhood fuse panel.

For Jetta's, connect the wire to SA4.

# Jetta

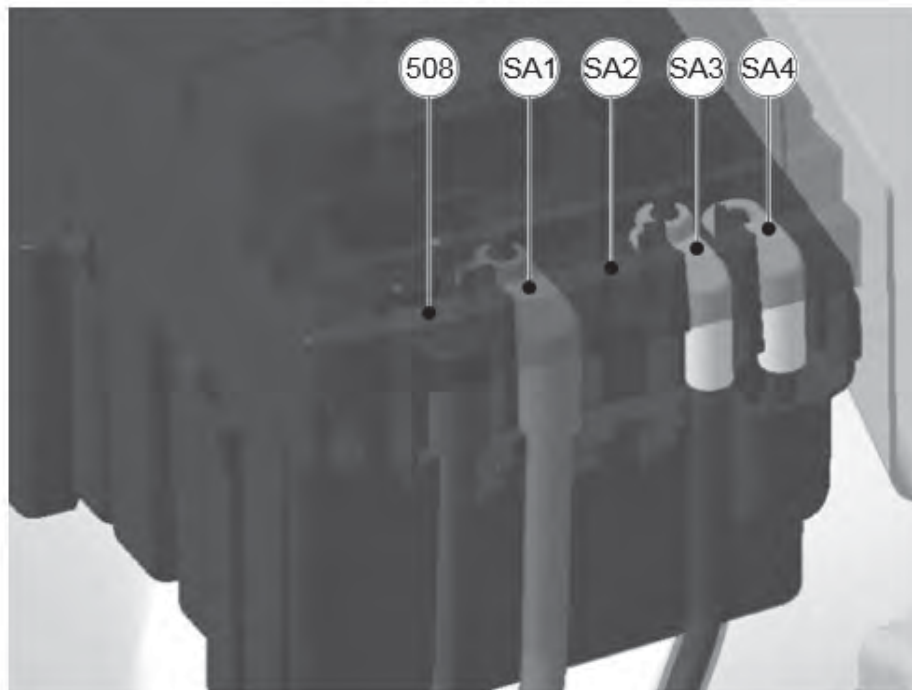

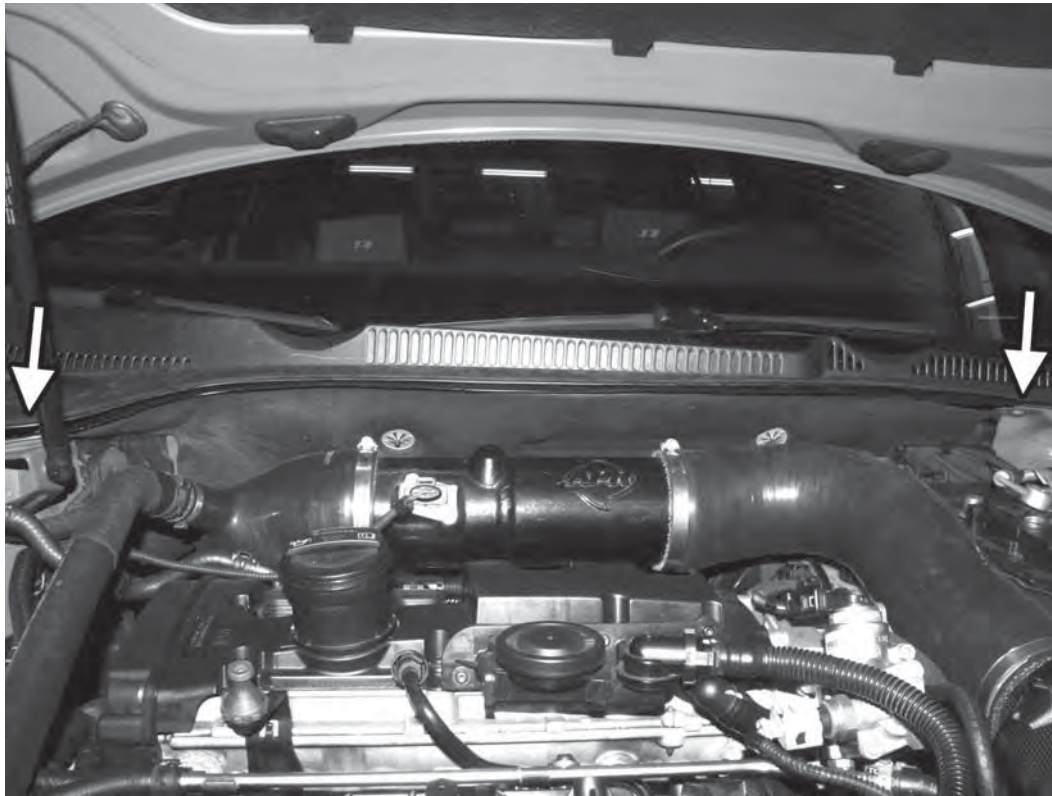

23) Remove the 10mm bolt from the right side of the firewall bulkhead, underneath the rain tray. Remove the 10mm nut from the left side of the firewall bulkhead underneath the rain tray, and then carefully lift the firewall bulkhead out of the car.

24) Remove the top plastic half of the of the wiring harness bulkhead connection on the left side of the car.

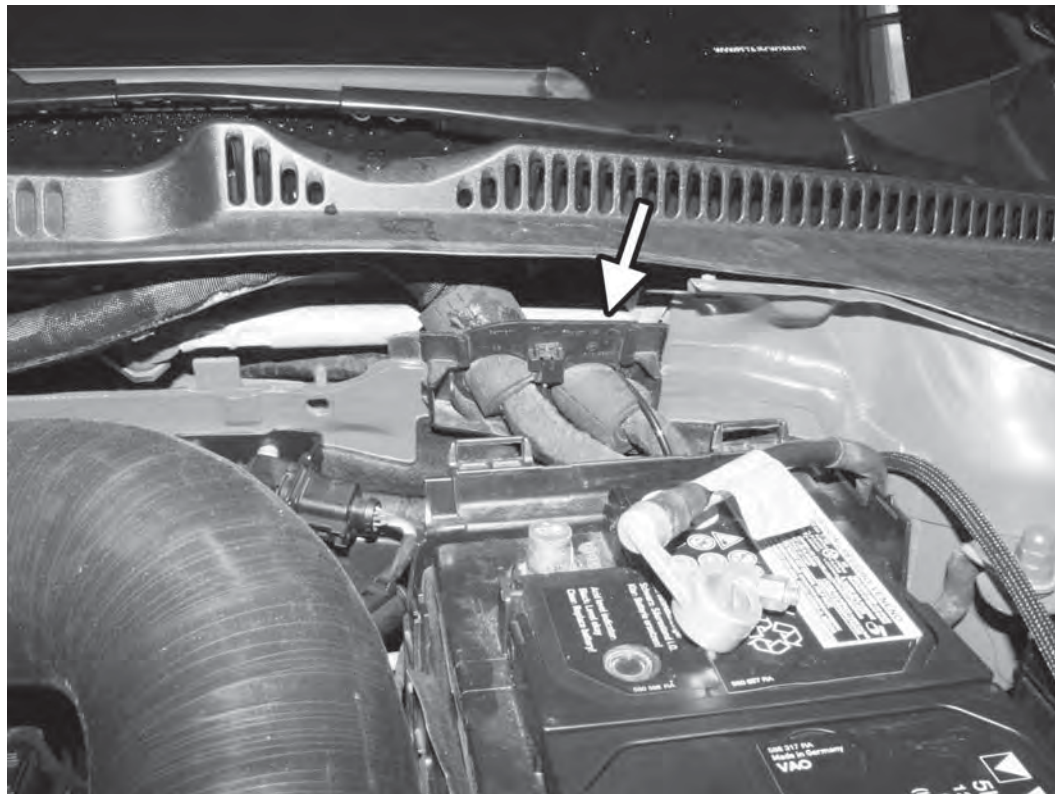

**APR, LLC**

4800 US HWY 280 West Opelika Alabama 36801

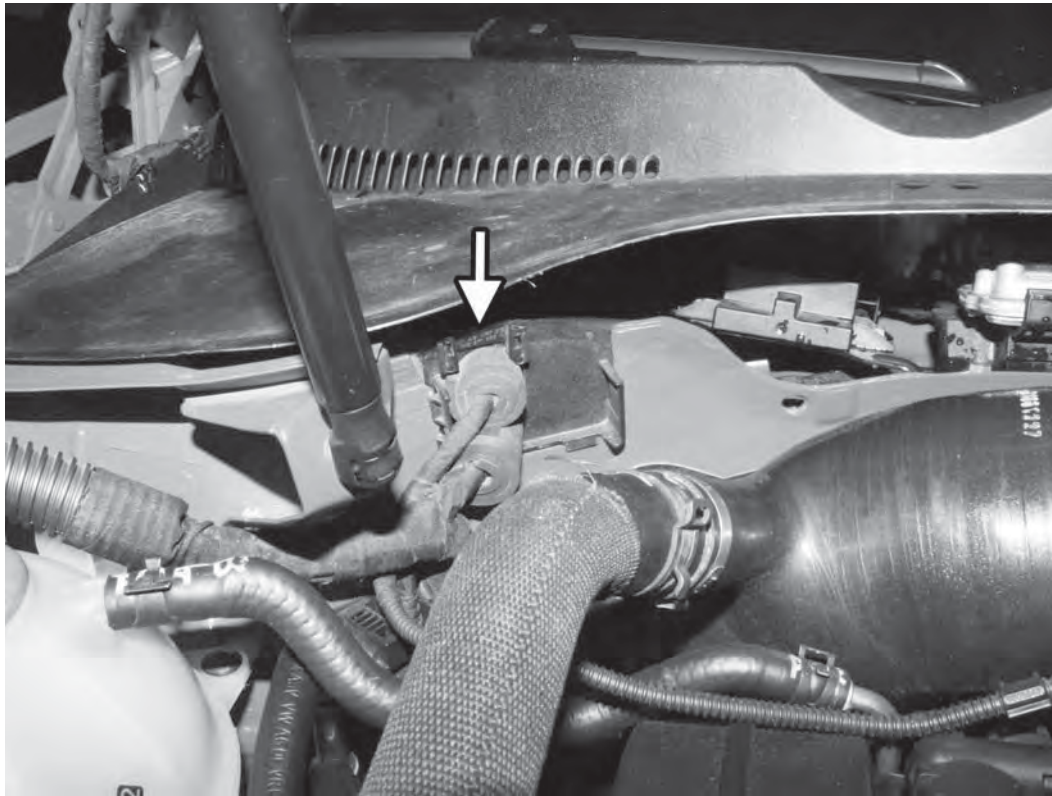

25) Remove the top plastic section of the of the wiring harness bulkhead connection on the right side of the car.

26) Route the long cable from the CAN controller back to the left of the battery and into the left opening in the firewall.

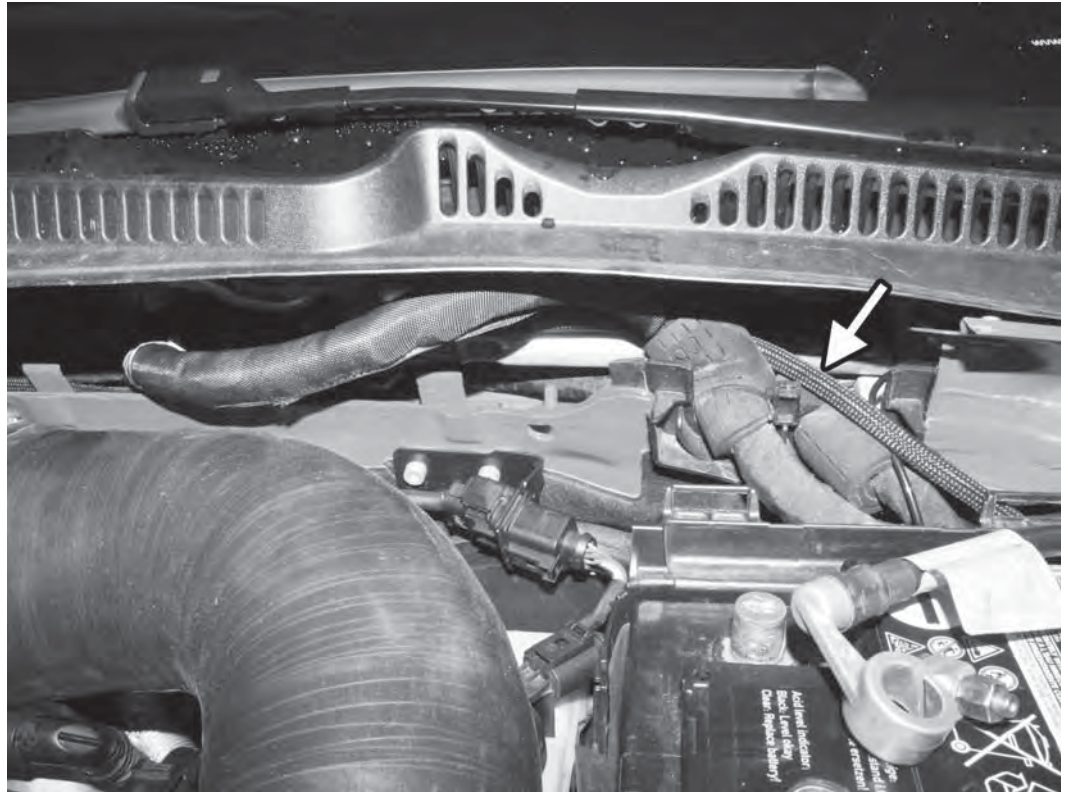

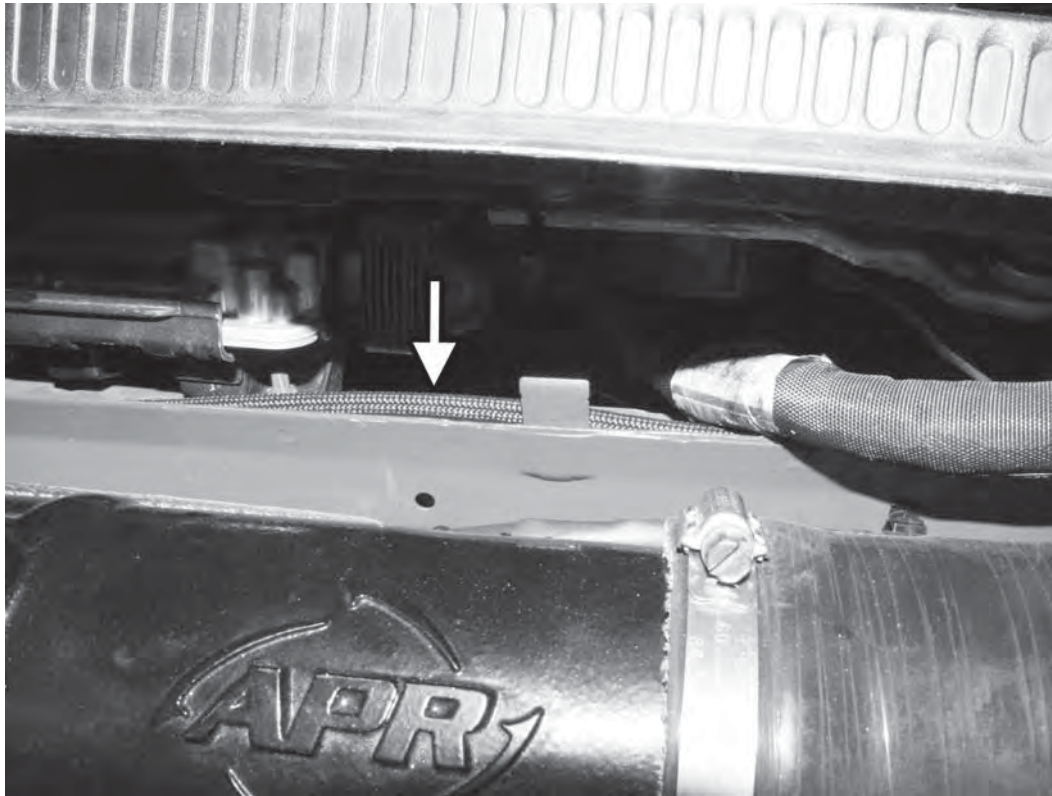

27) Route the cable behind the tabs for the firewall bulkhead.

28) Route the long cable out of the right opening in the firewall and down between the engine and frame rail, and to the right of the air conditioning lines.

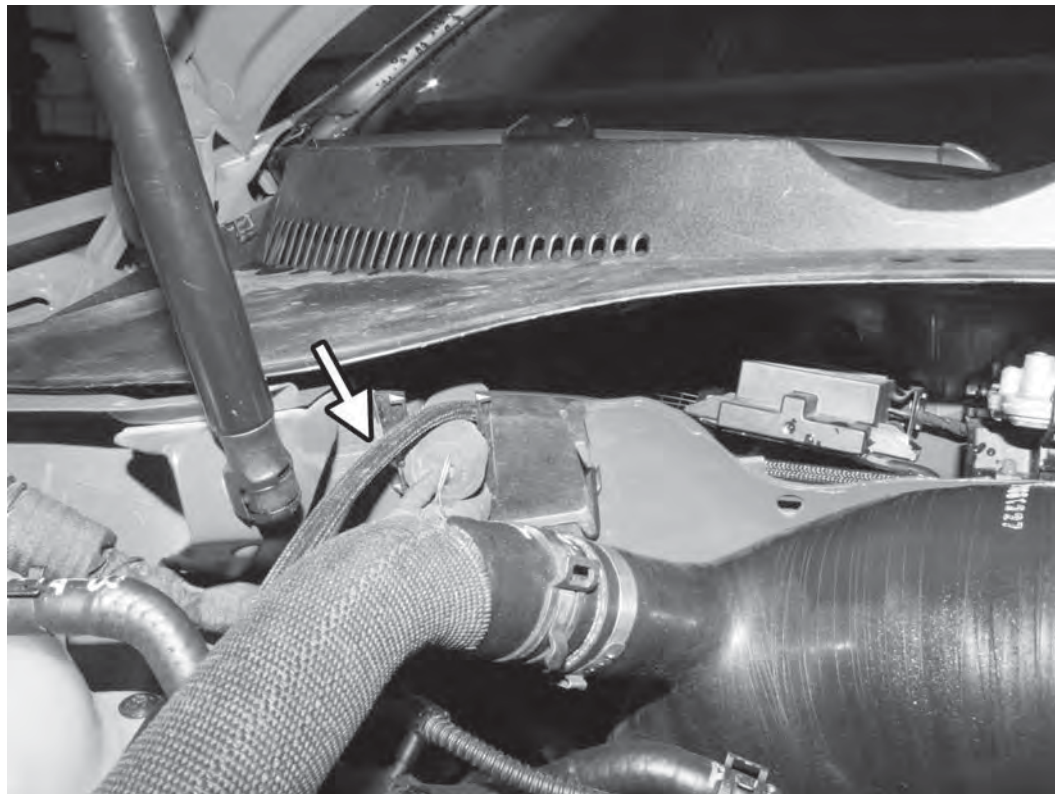

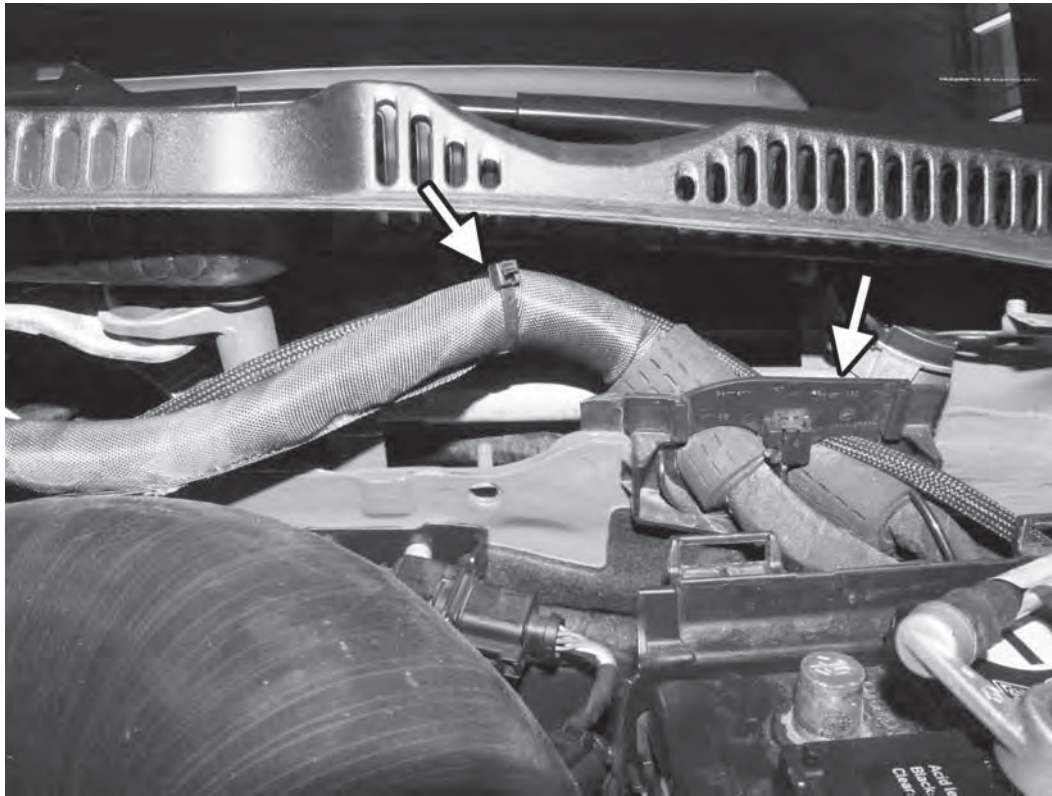

29) Replace the top of the plastic wiring harness bulkhead on both the right and left side of the firewall. Install a cable tie to secure the APR harness to the factory wiring harness to keep the APR harness away from the windshield wiper assembly.



30) Replace the factory firewall bulkhead, making sure the bulkhead goes back into the tabs on the firewall, and that the APR harness is not pinched or moved. Secure the bulkhead with the factory 10mm nut and 10mm bolt, and reinstall the factory weatherstripping.

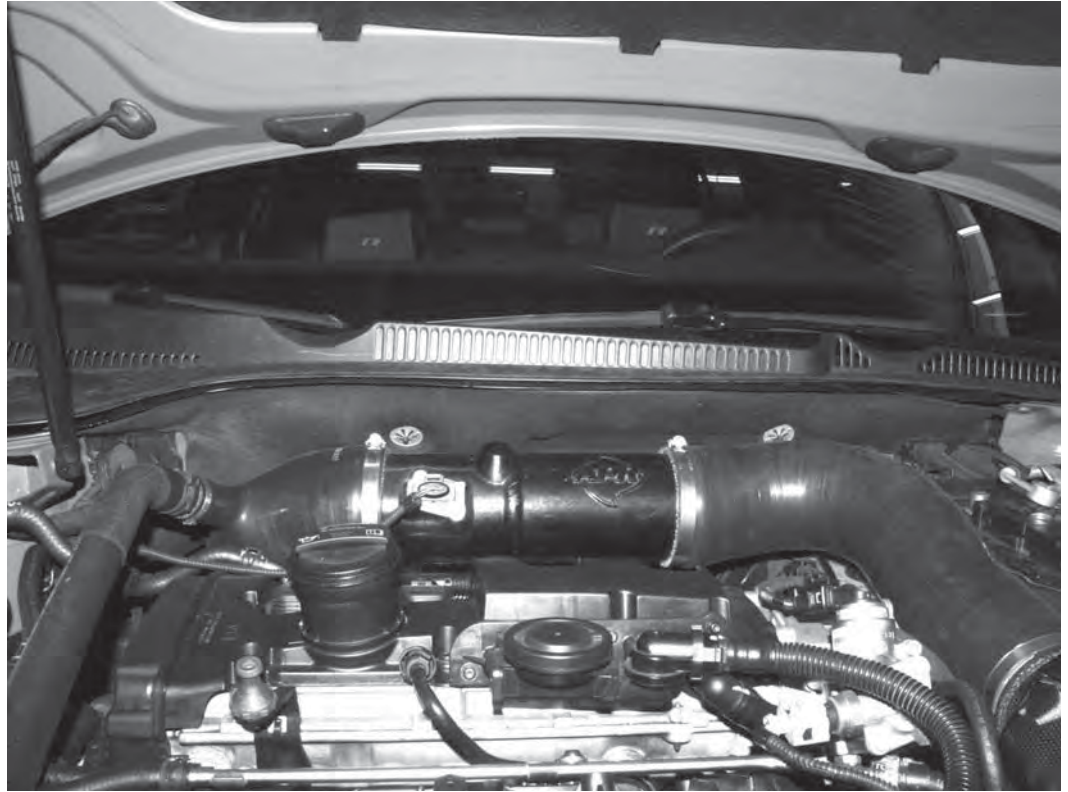

**APR, LLC**

4800 US HWY 280 West Opelika Alabama 36801

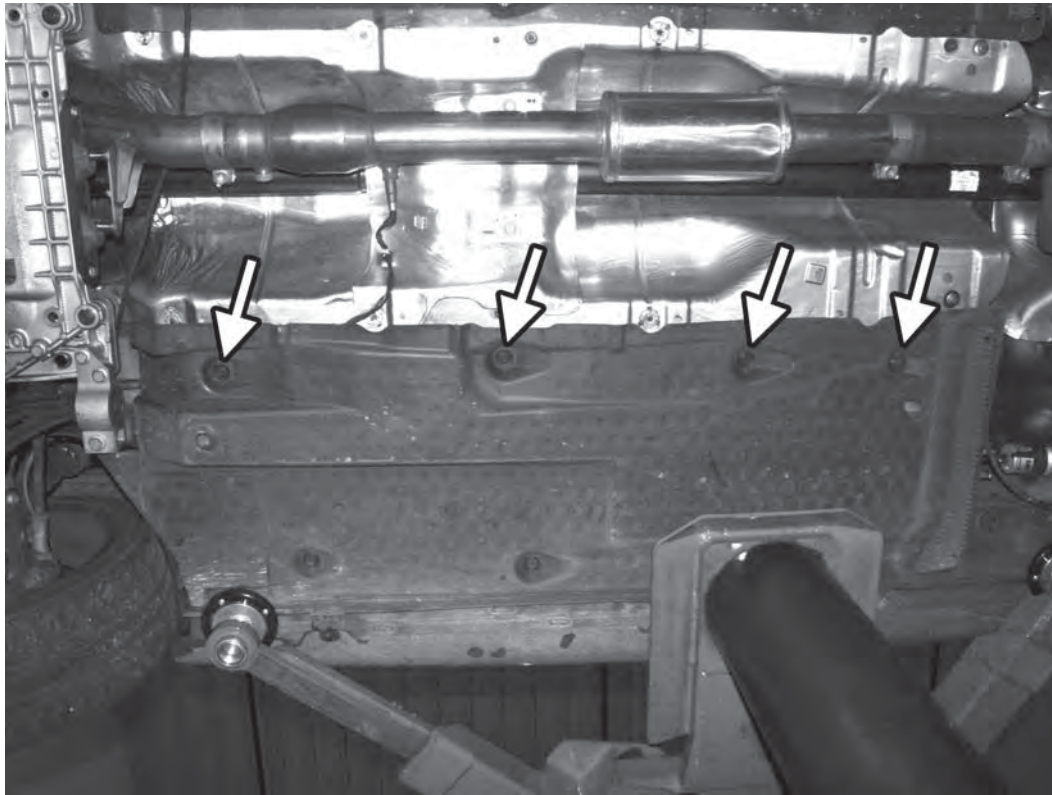

31) Remove the four 10mm plastic nuts from the inner side of the right belly cover for access to the route the APR harness.

32) Route the APR harness from above, making sure to keep the harness away from heat and any moving parts. Route the cable along the oxygen sensor harness underneath the car.

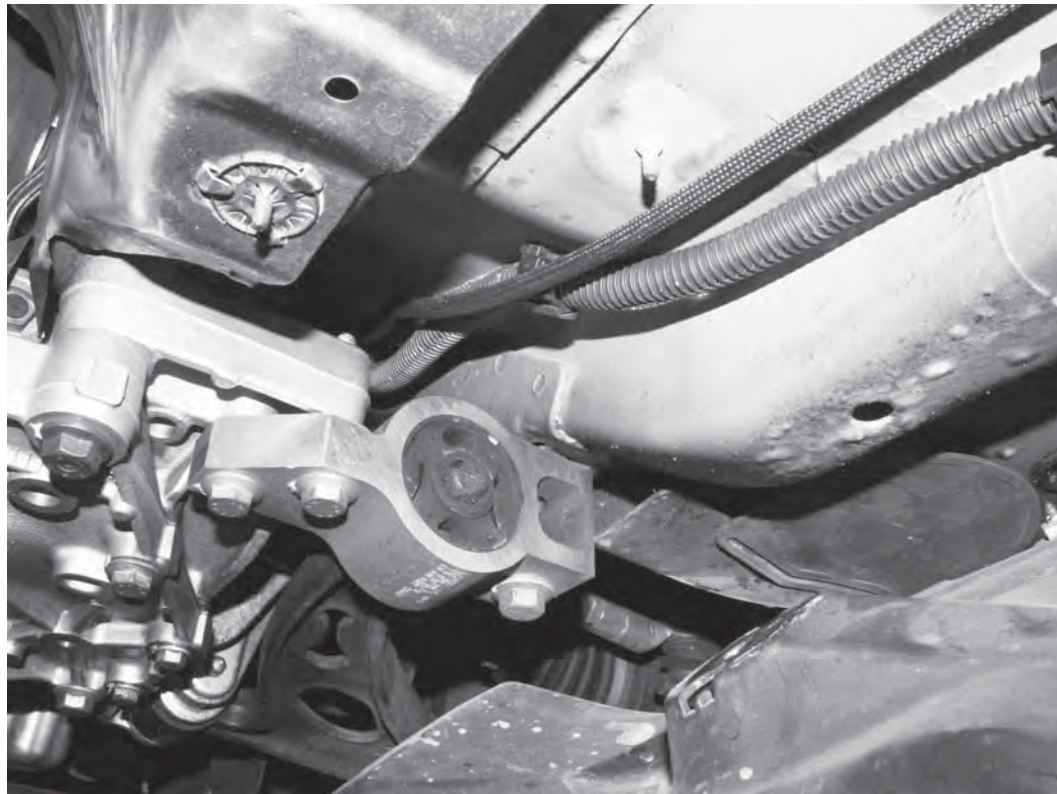

**APR, LLC**

4800 US HWY 280 West Opelika Alabama 36801

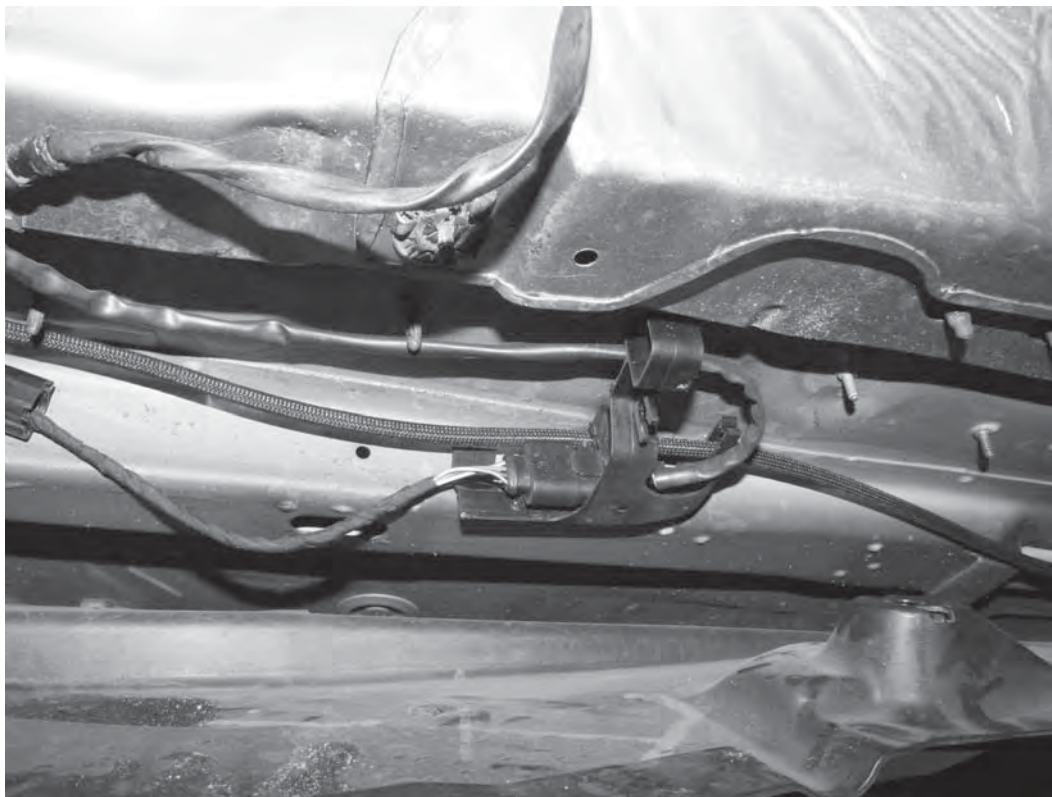

33) Route the APR harness above the oxygen sensor connection mounting bracket.

34) Route the APR harness back along the factory fuel lines, and clip into an open position on the fuel line mounting clips.

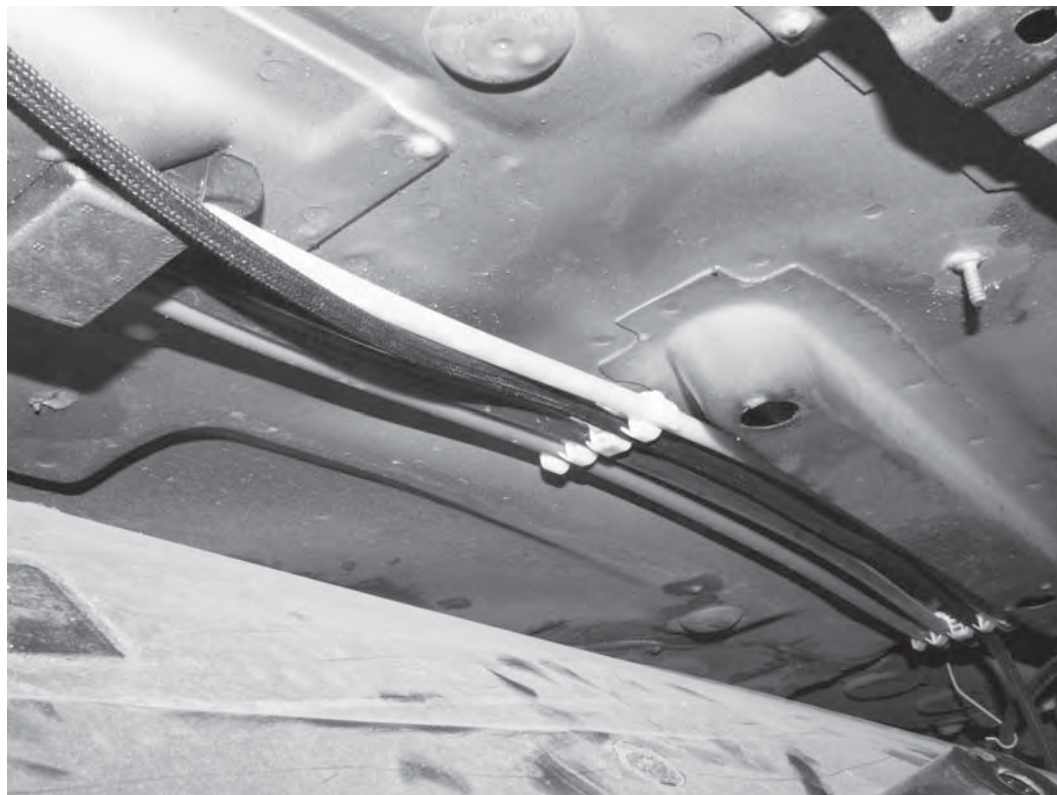

**APR, LLC**

4800 US HWY 280 West Opelika Alabama 36801

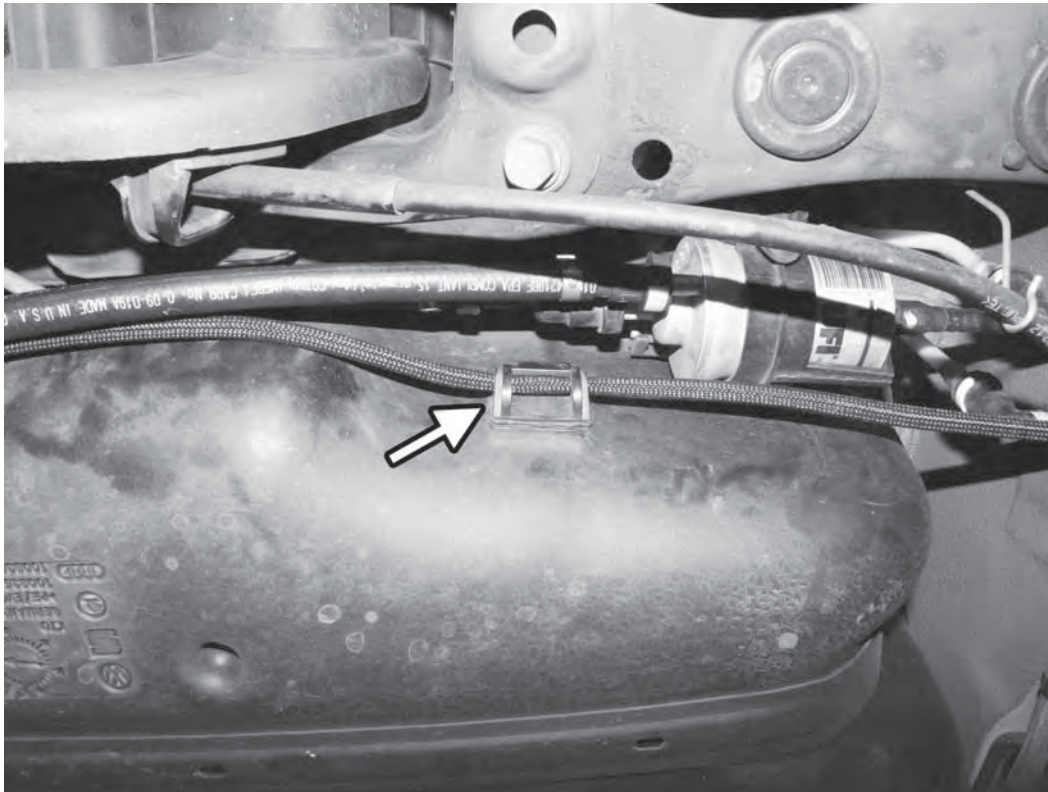

35) If equipped on the vehicle, attach the APR harness to the right side of the fuel tank with a cable tie.

36) Route the APR harness over the subframe, along the same path as the APR fuel lines. Secure the two fuel lines and harness together with cable ties.



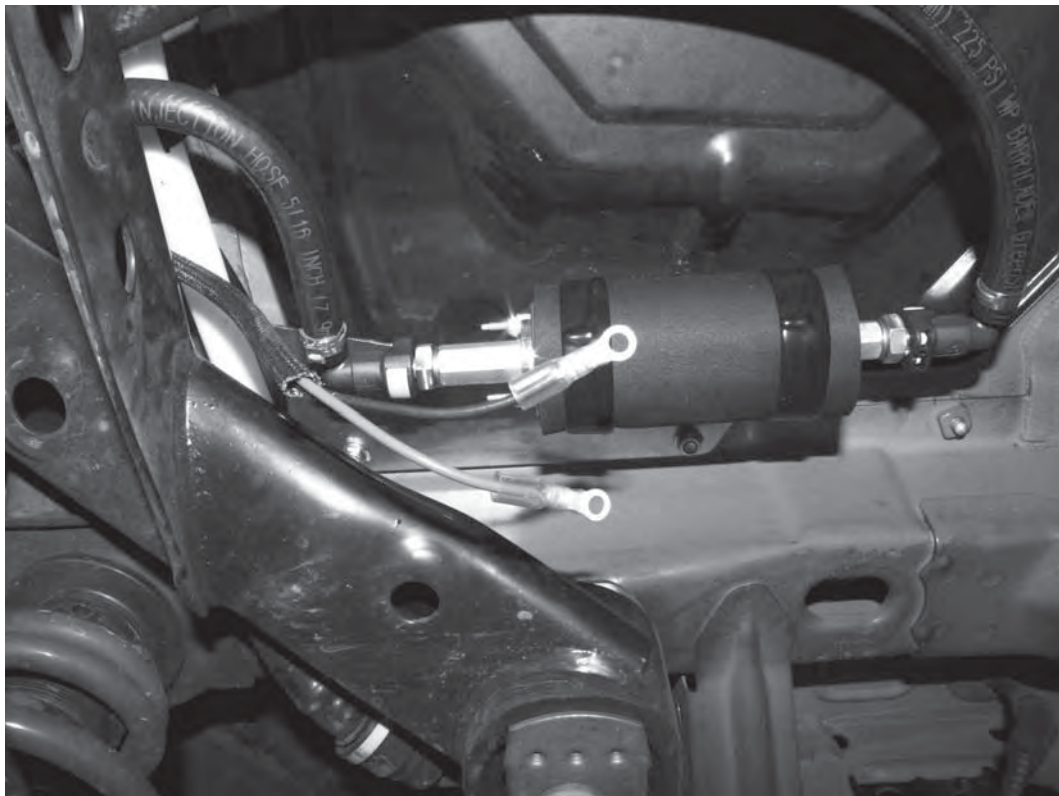

37) Carefully trim back the sleeving on the APR harness and cut the wires to an appropriate length. Strip the wires and crimp the two supplied ring terminals. Once crimped, evenly heat the terminal with a small butane torch or other adequate heat source to seal the shrink wrap.



38) Install the red wire to the terminal marked with a "+" on the APR pump, and connect the black wire to the terminal marked with a "-" on the pump. Secure with the two 8mm nuts.

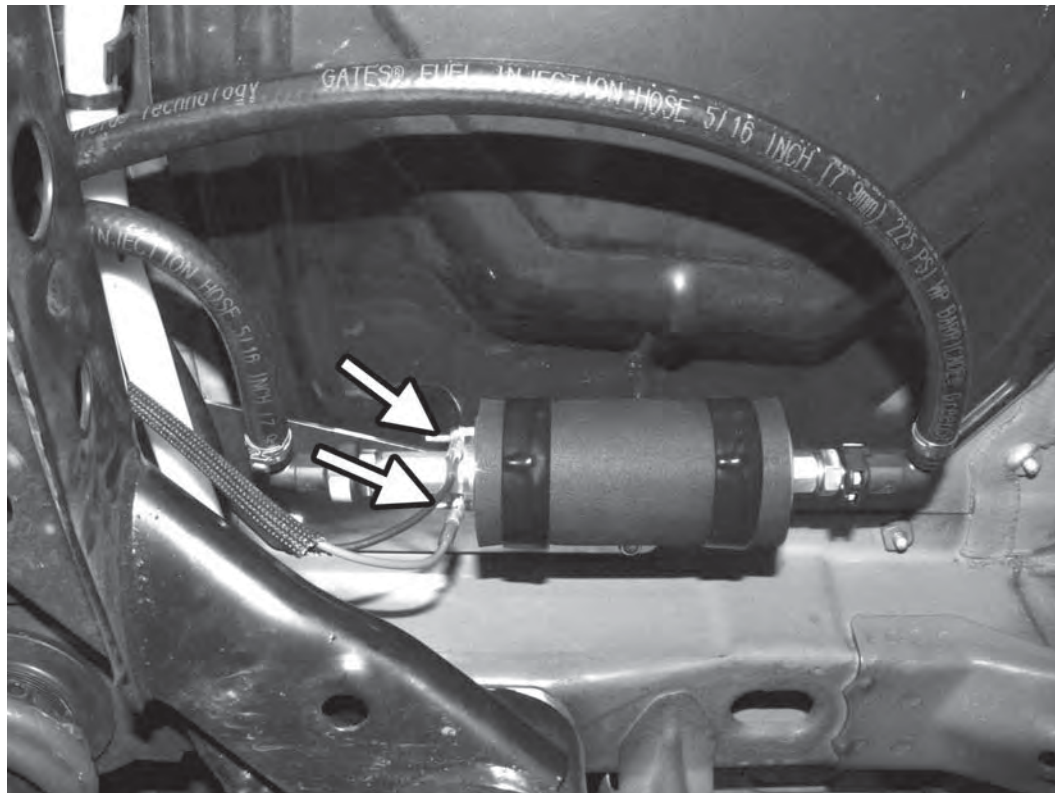

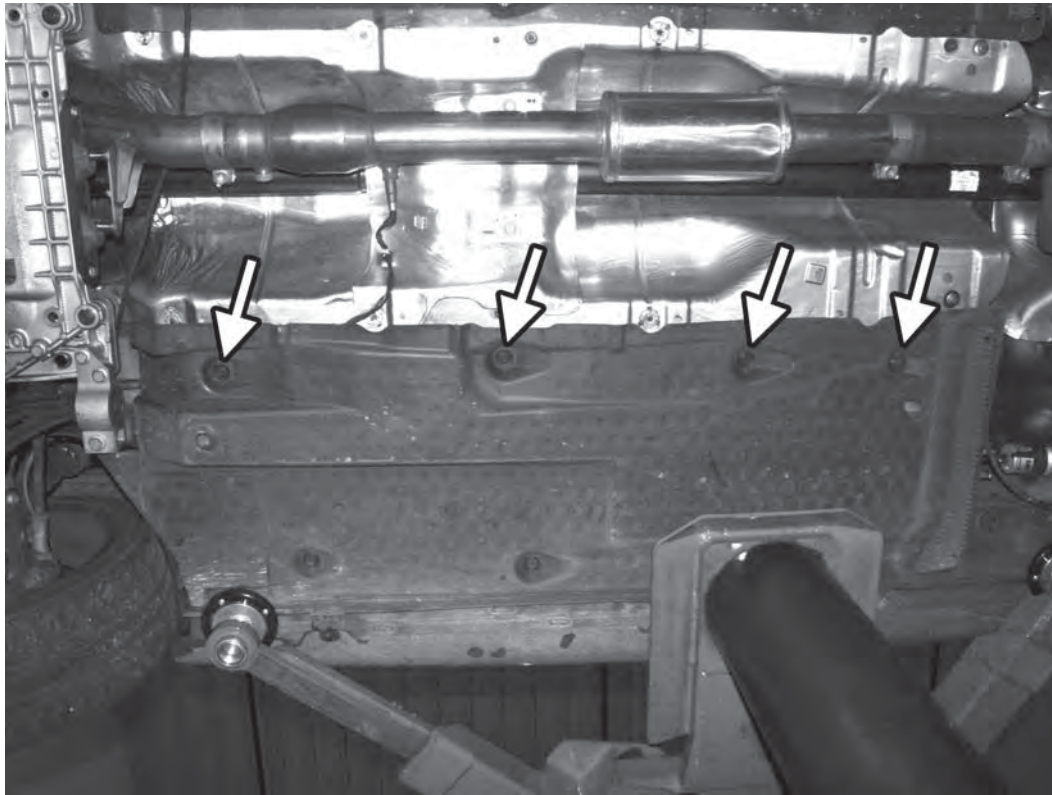

39) Replace the right side belly cover, securing with the four plastic 10mm nuts.

40) Reinstall and reconnect the battery in the vehicle. Torque the battery 13mm battery hold down bolt to 26 lb-ft. Test the APR LPFP by turning the ignition ON, with the engine OFF. If the button on the APR CAN Controller is pressed, the APR LPFP will run. Make sure no leaks are found by the APR pump and the factory fuel filter connections.



**APR, LLC**

4800 US HWY 280 West Opelika Alabama 36801

## APR CAN Controller Operation

	<b>OPS (Oil Protection System)</b>	<b>LPFP</b>
Ignition OFF, Engine OFF	If the Button on the APR CAN controller is pressed and held down, the LED should illuminate solidly and the OPS solenoid will fire to dump the contents of the OPS tank.	No Indication
Ignition ON, Engine OFF	No Indication	If the Button on the APR CAN controller is pressed and held down, the LED should illuminate solidly and the APR LPFP will run continuously.
Ignition ON, Engine ON	If the engine RPM is above 1500, the LED on the CAN controller should flash twice per second, unless the LPFP is activated.	If the engine RPM is below 1500, the LED on the CAN controller should flash once every three seconds, unless the LPFP is activated. If the engine RPM is above 1500 AND engine load is high, the LED will illuminate solid indicating the LPFP is activated.

The APR LPFP also provides an easy way of changing fuel in the vehicle. Simply disconnect the factory fuel line to the engine at the Bundy fitting by the right frame rail.

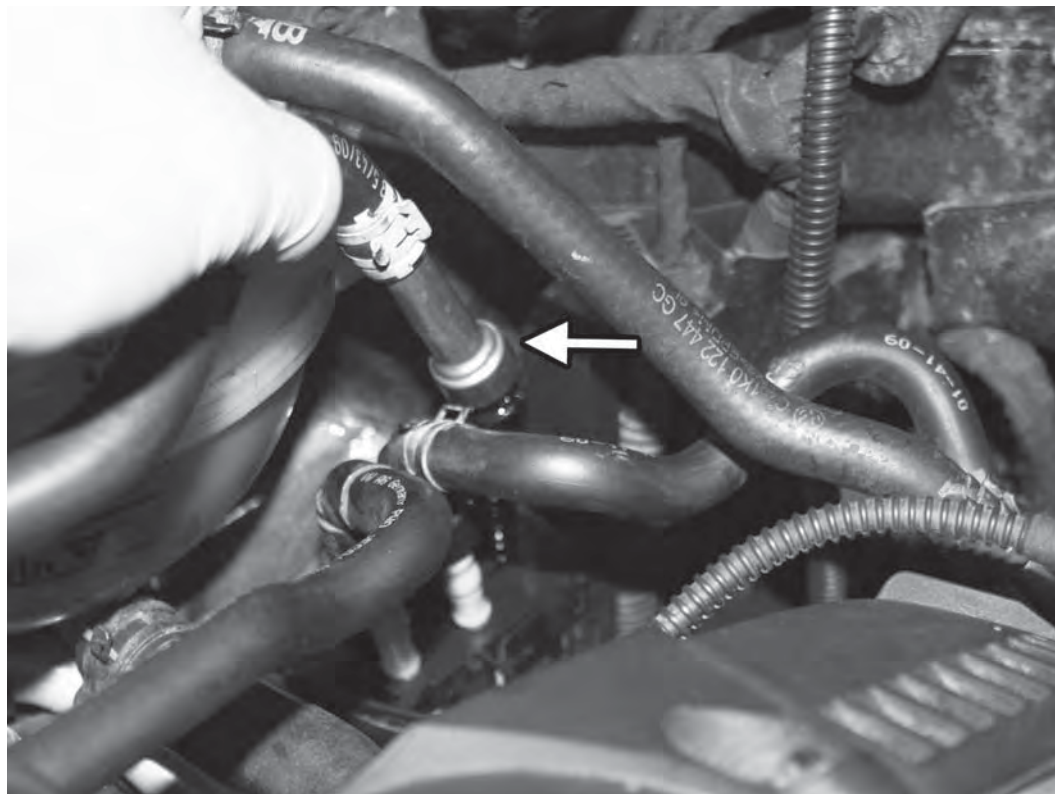

**APR, LLC**

4800 US HWY 280 West Opelika Alabama 36801

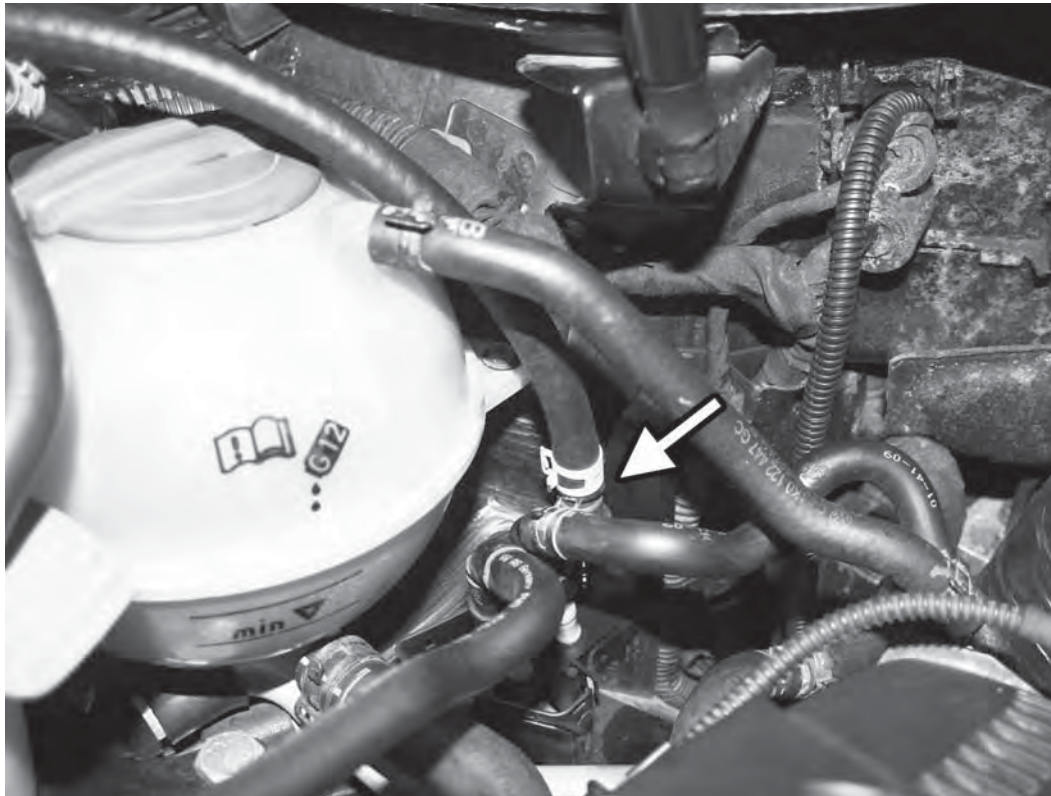

Connect the extra supplied female Bundy fitting to the excess fuel line supplied in the kit with a hose clamp. Connect the Bundy fitting to the male port in the engine bay. Simply turn the ignition on, and press and hold down the button on the APR CAN controller until the fuel tank is empty. Remove the drain line, reattach the factory fuel line, and fill the car with the fuel of your choice.



#TL00037



**APR**

LOW PRESSURE FUEL PUMP  
INSTALLATION INSTRUCTIONS