

S5 SUPERCHARGER INSTALLATION INSTRUCTIONS



APR, LLC

4800 US HWY 280 West Opelika Alabama 36801

4800 US HWY 280 West Opelika Alabama 36801
APR, LLC

Notes:

These instructions were written on a 2008 S5, but there are minor variations throughout the model run of the S5.

When disassembling the car, be sure to keep and mark all fasteners so they can be reused. It is recommended that you get some kind of compartmented tray to organize the fasteners, such as a fishing tackle box or several large ice cube trays. Fasteners that are not reused for reinstallation are noted in the instructions.

These instructions assume that you have moderate mechanical skills and several varieties of the tools listed in order to install the kit. If you have any questions about the install, feel free to contact your APR representative.

1) Securely lift vehicle. If a vehicle lift is not used, secure the vehicle with jack stands. Remove both front wheels.



2) Remove the 11 quarter turn fasteners from belly pan with a screwdriver and remove the belly pan.

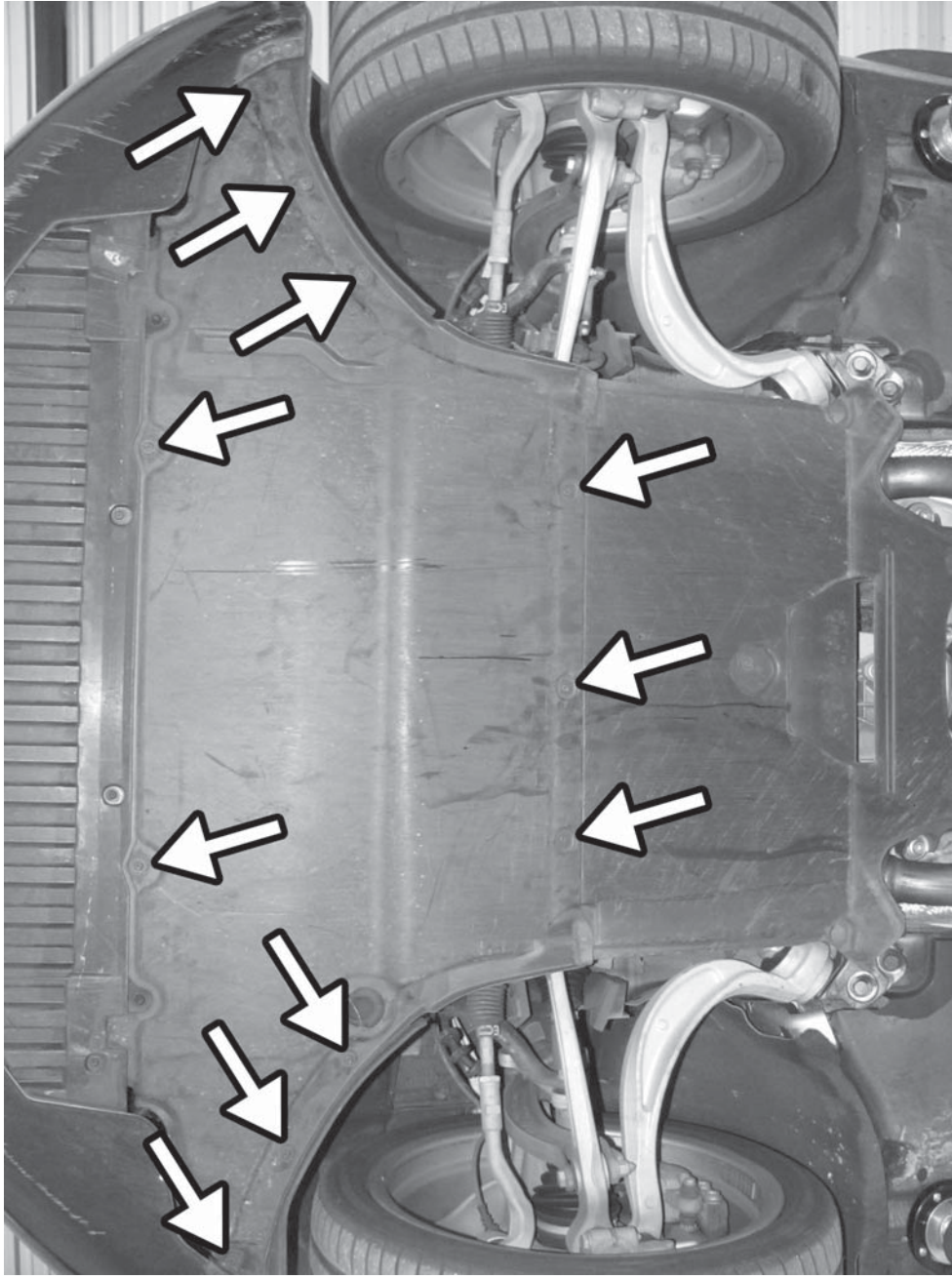

3) Remove the 4 T30 Torx screws from bottom of bumper cover.

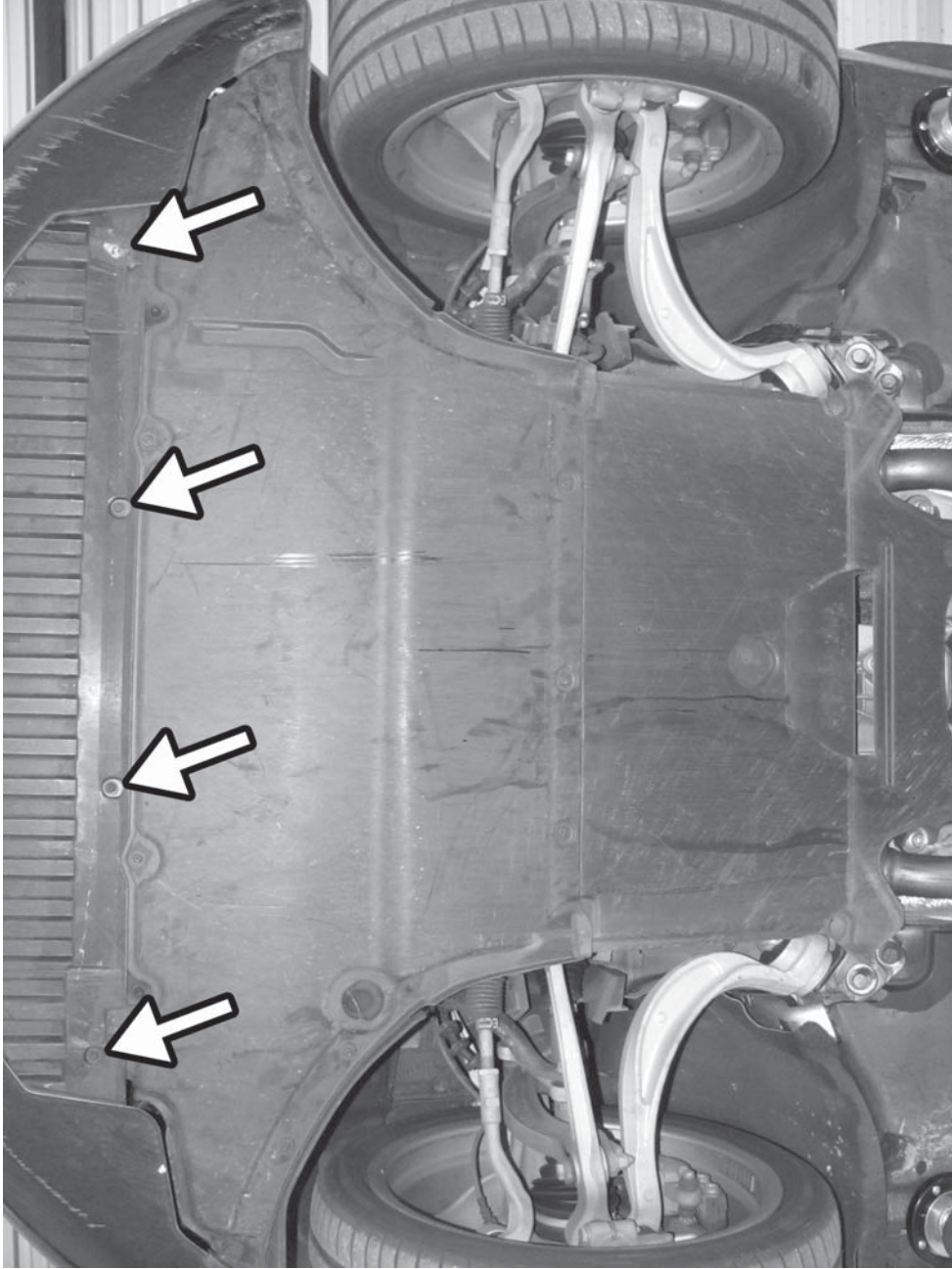

4) Remove 2 outer T25 Torx screws from fender well liner and the outer plastic clip. Repeat on both sides.

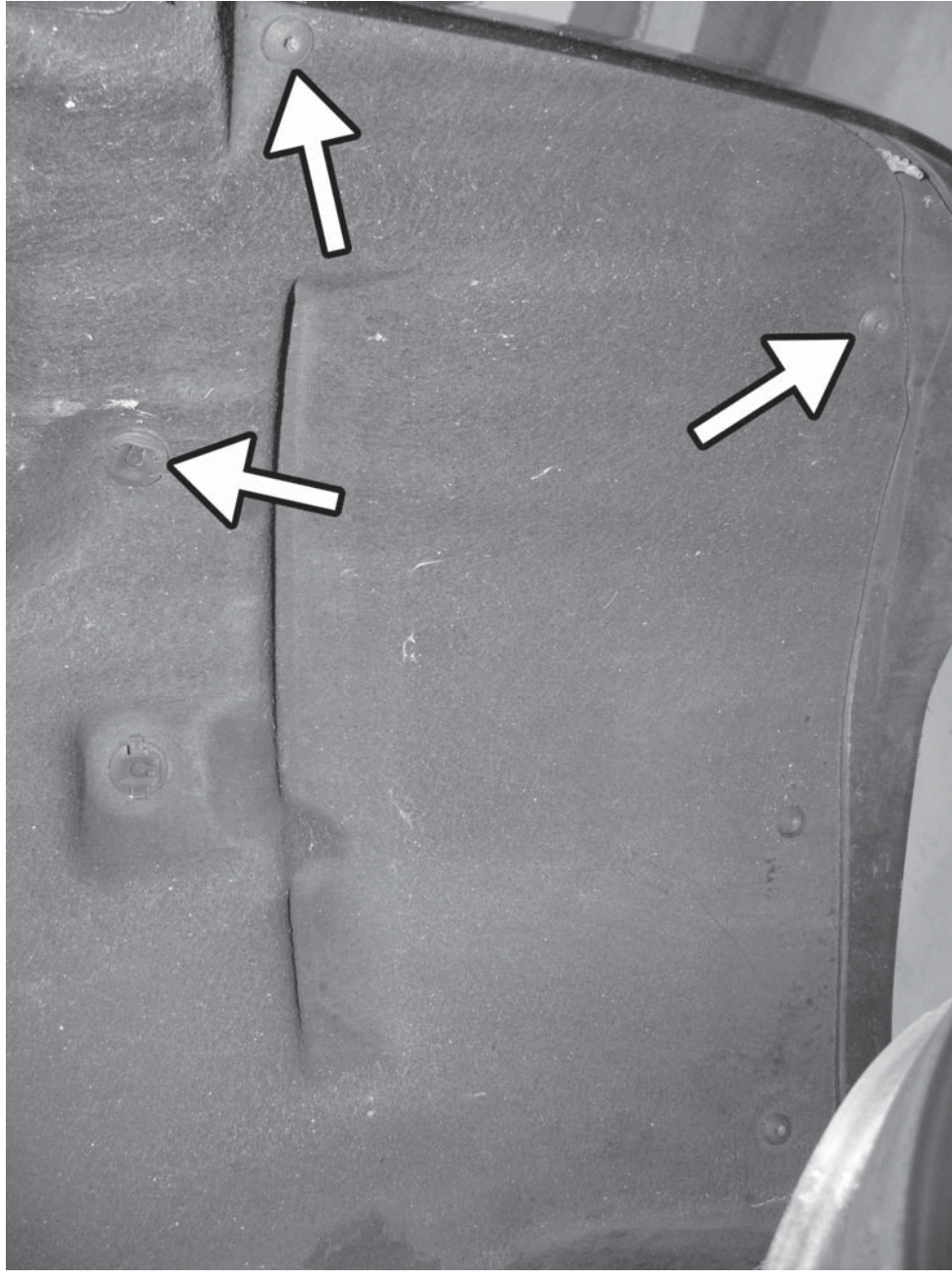

5) Pull back fender liner and remove the two 10mm bolts from bumper cover. Repeat on both sides.

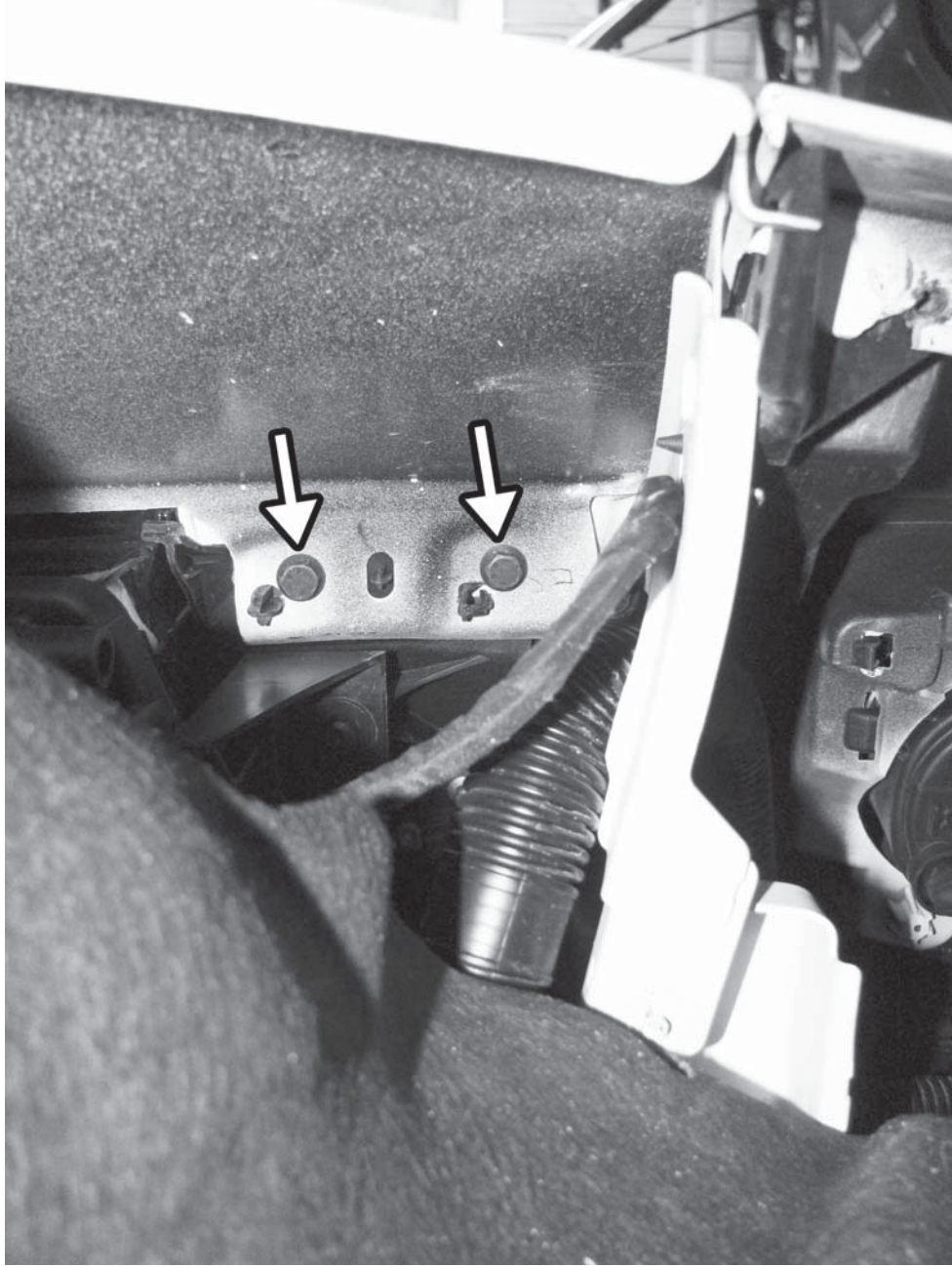

6) Remove 4 T30 Torx screws from upper bumper trim cover and remove the cover.

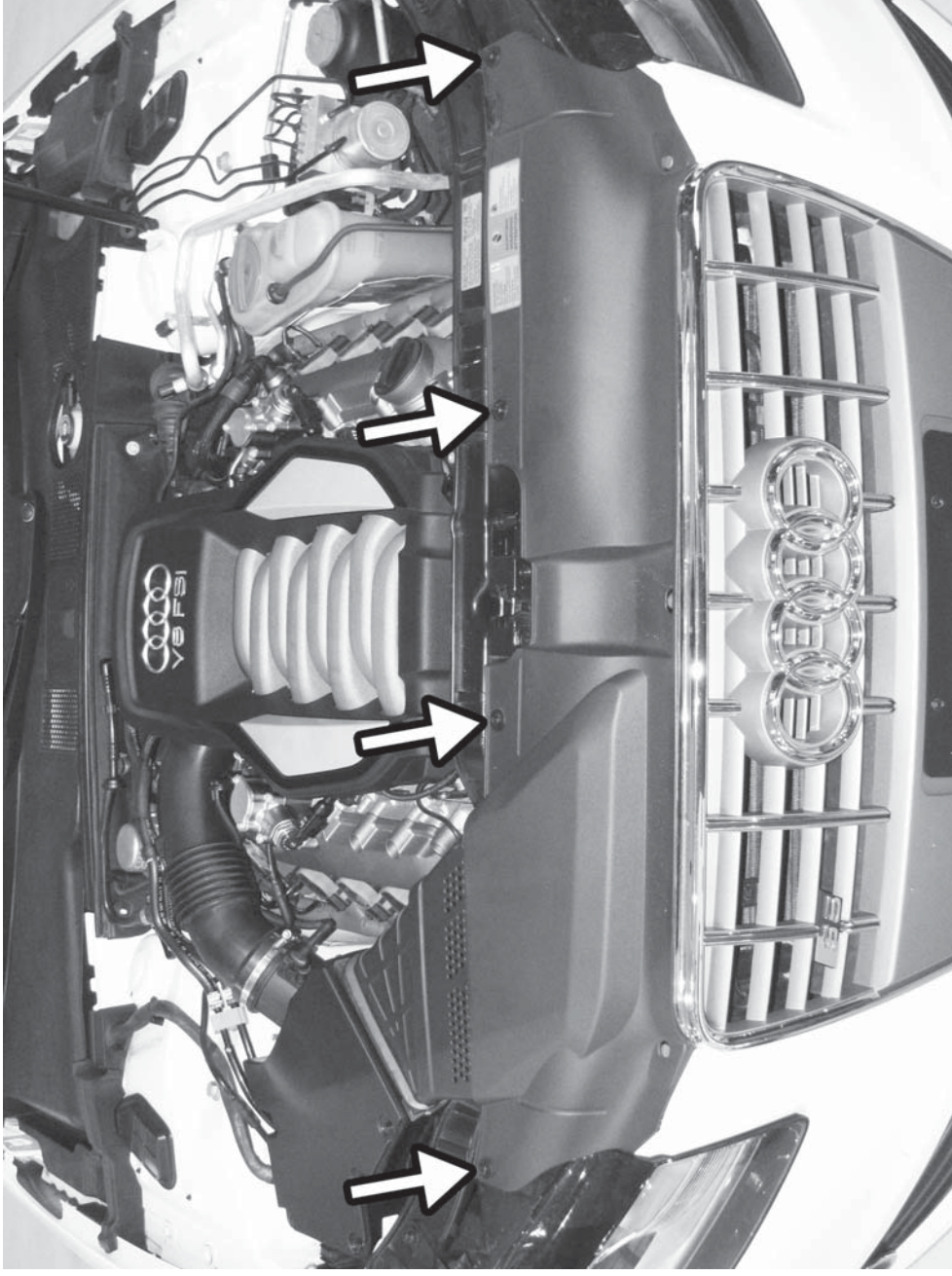

7) Remove 2 T25 Torx screws from top of bumper cover.

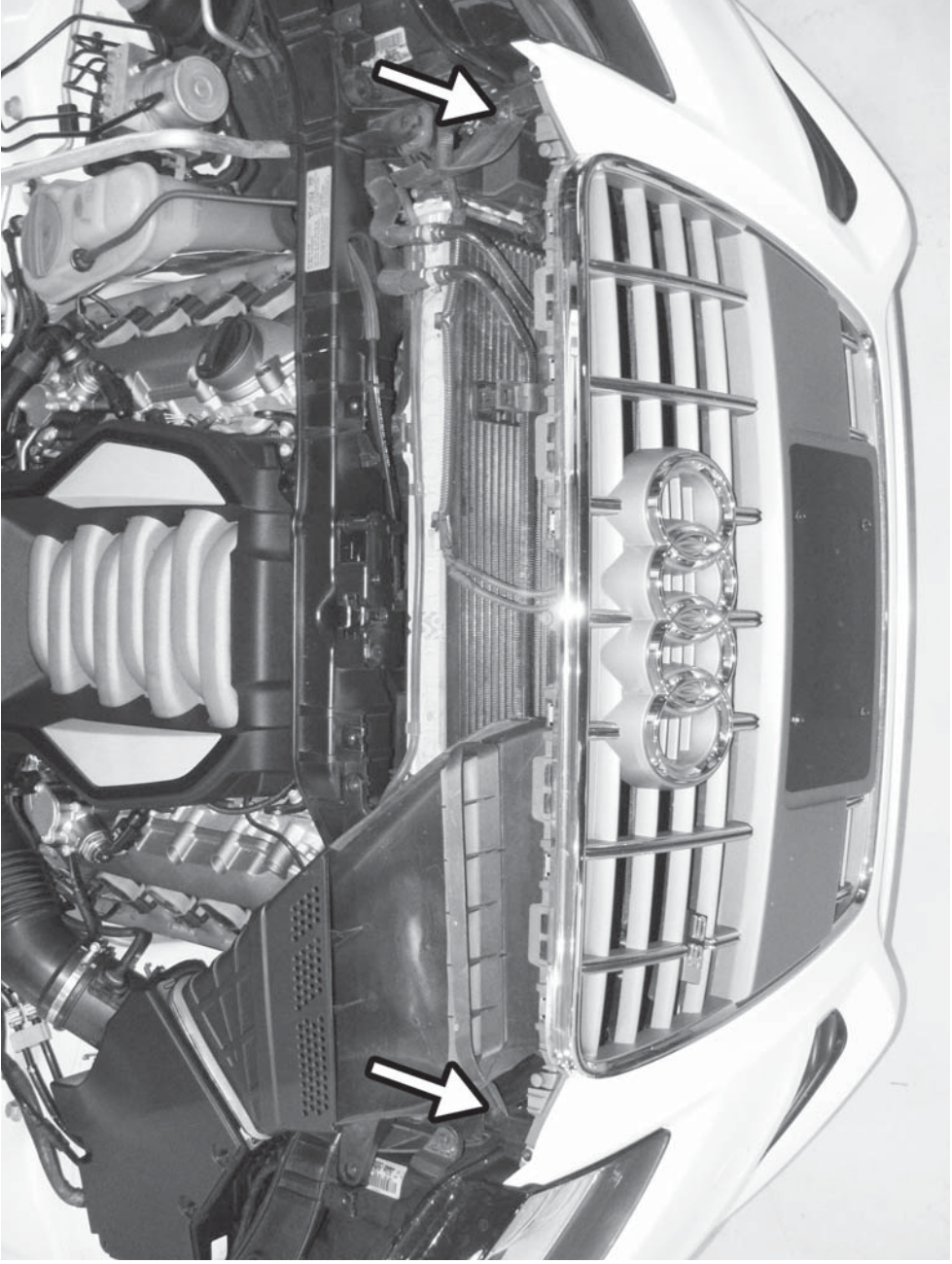

- 8) Carefully pop the upper corner of bumper cover out. Repeat on opposite side.



9) Carefully pull bumper cover forward and disconnect left and right fog light harness. Also disconnect the Homelink transmitter and outside air temperature sensor from the front of the grille. Remove bumper cover and set aside so it will not get damaged.



- 10) Remove the two T30 Torx screws from bottom of radiator core support.

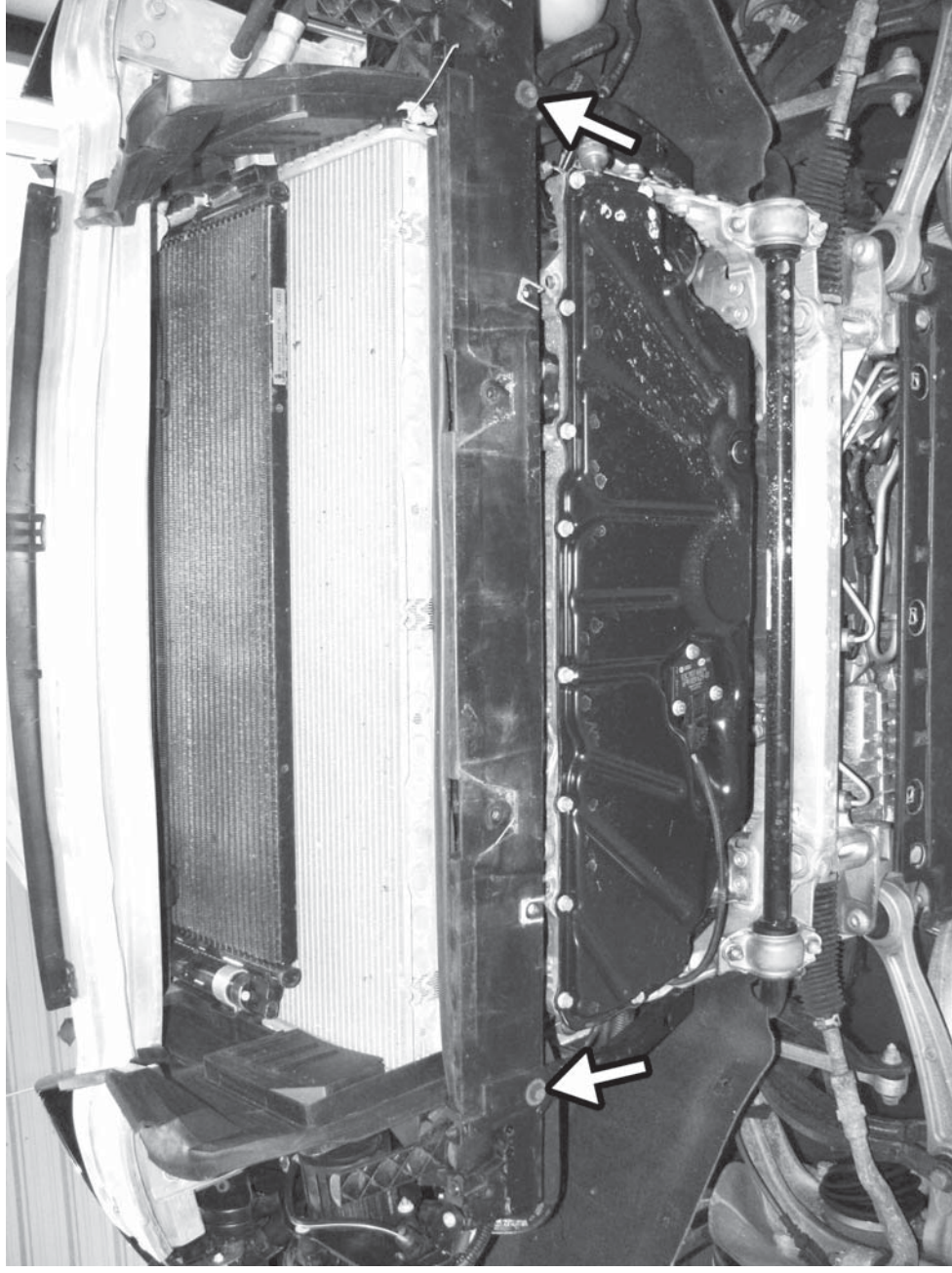

11) Remove 2 T30 Torx screws from top of radiator core support.

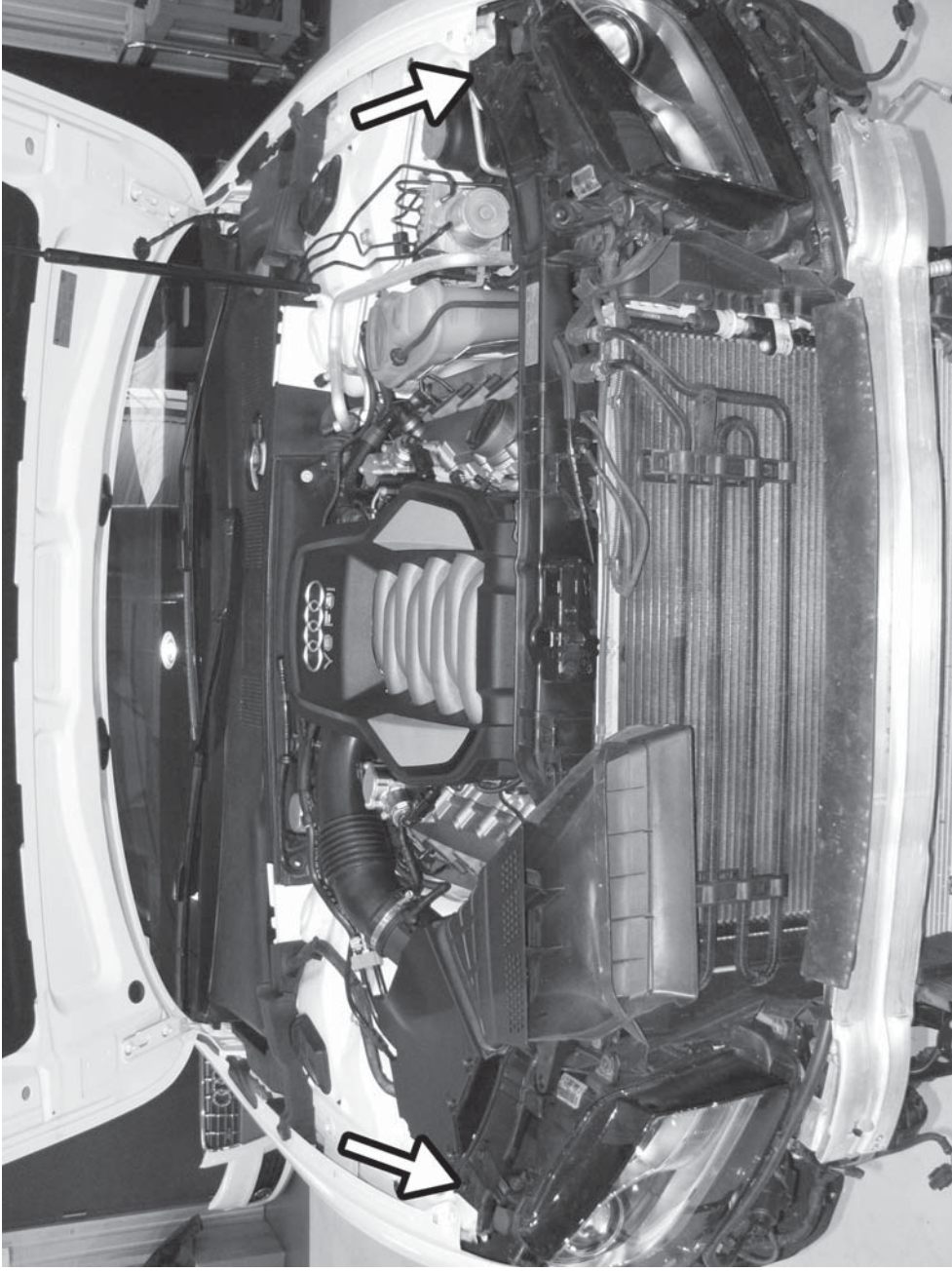

12) There are six 16mm bolts attaching the radiator core support to the front frame rails. ONLY remove the lower, outer bolts on both sides and replace these with the long bolts supplied with the APR Supercharger kit. Only thread the bolts in to the same depth as the factory fastener.

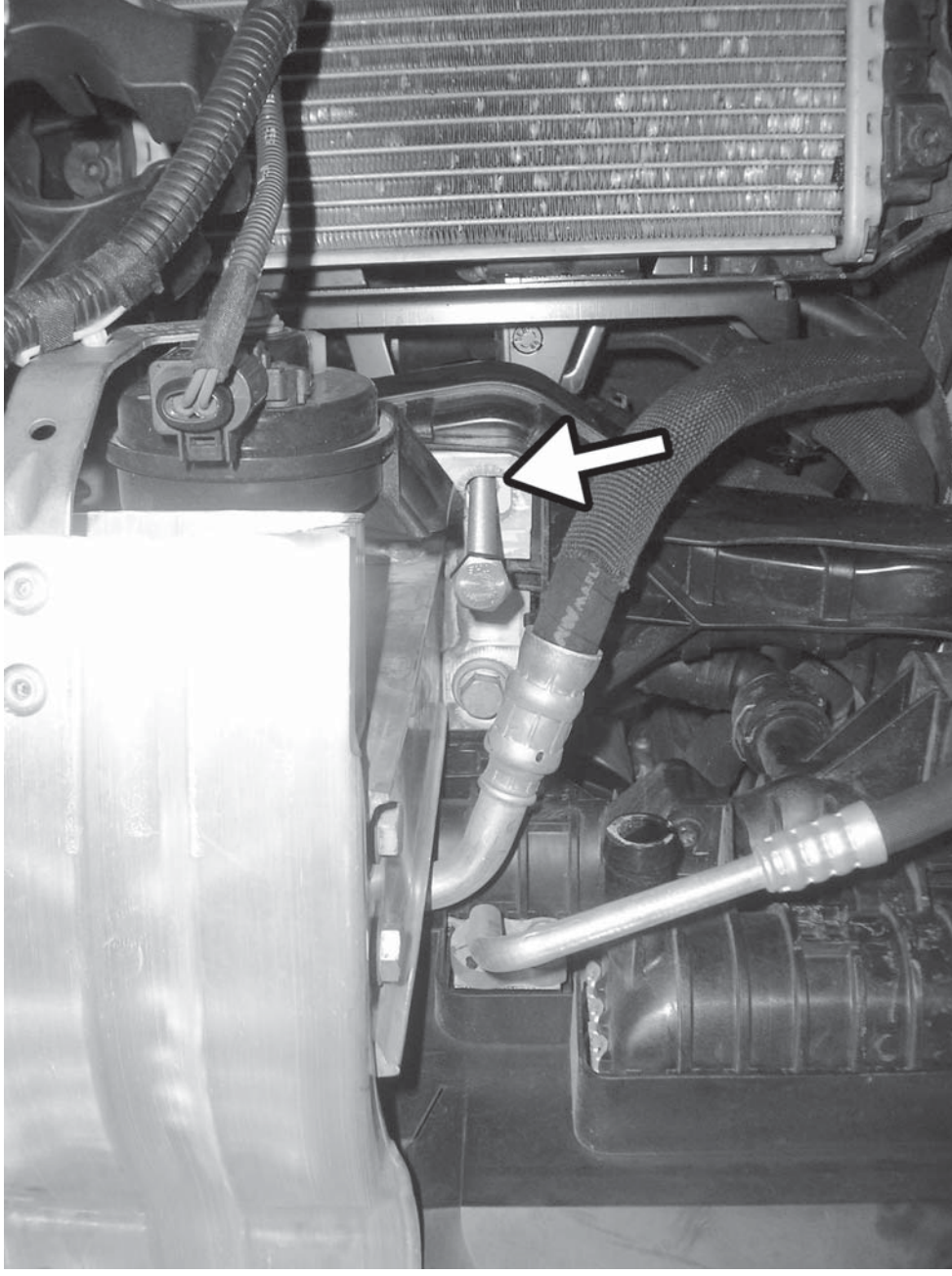

13) Remove the remaining four 16mm bolts holding the core support to the frame rails.

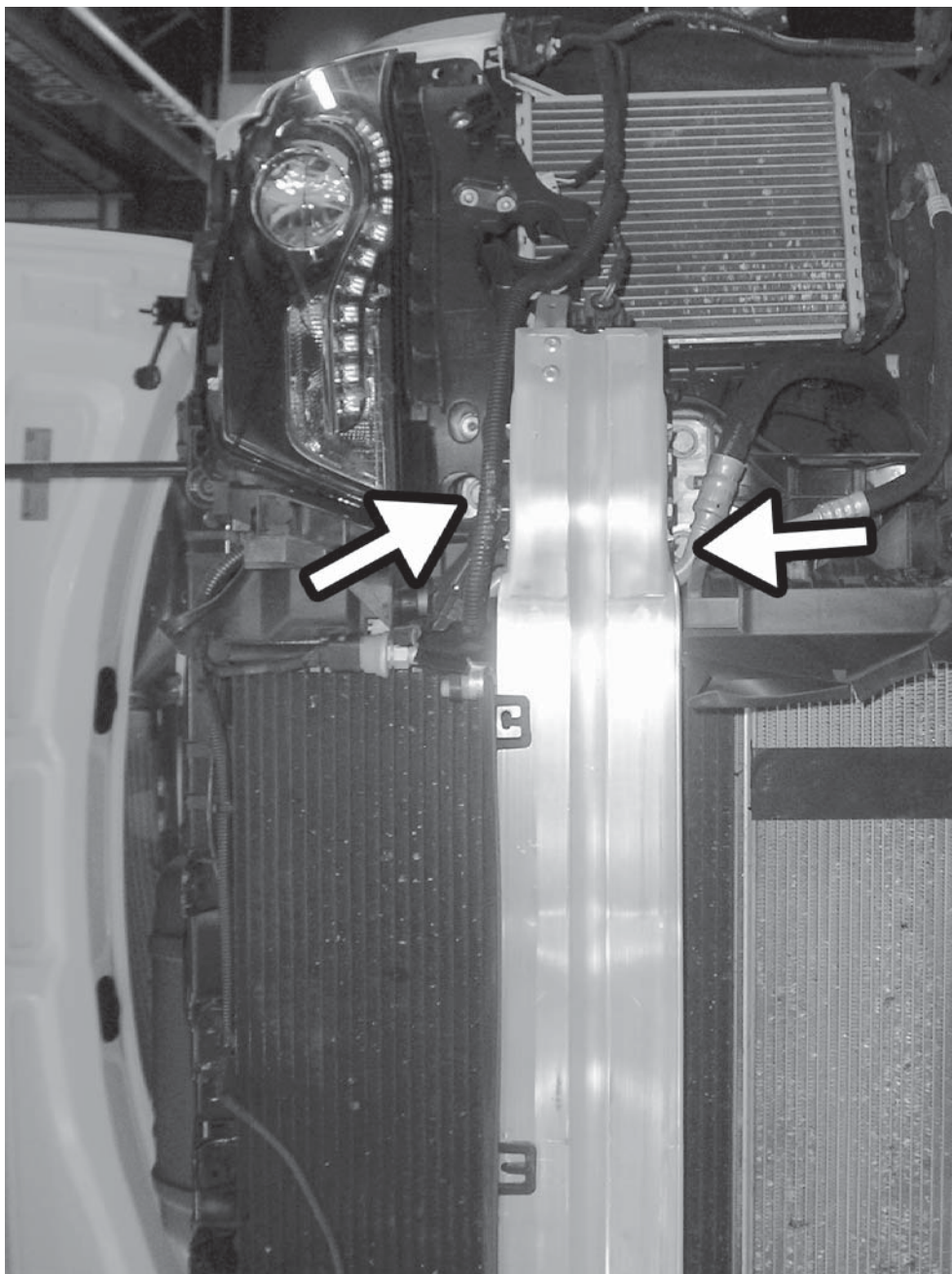

14) Disconnect coolant bleed line from expansion tank.



15) Disconnect the horn connectors from both sides of the bumper beam and unclip the wiring harnesses from the beam.



16) Remove the plastic air duct off the top of the bumper beam. Also disconnect the plastic clip holding the headlight washer hose to the bumper beam.

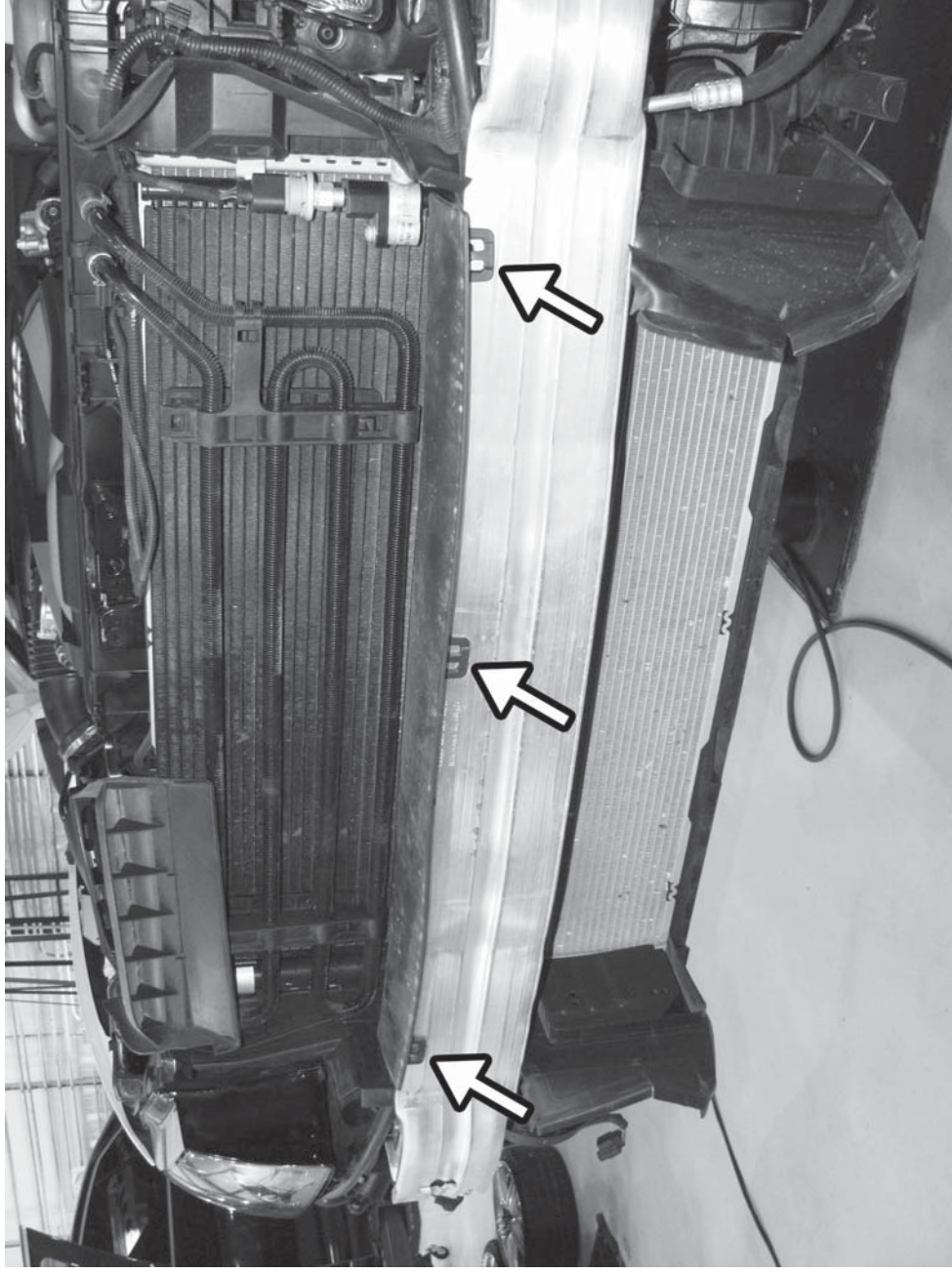

17) Remove the four (two from either side) 13MM screws from the bottom of the bumper beam and remove the beam from the car.

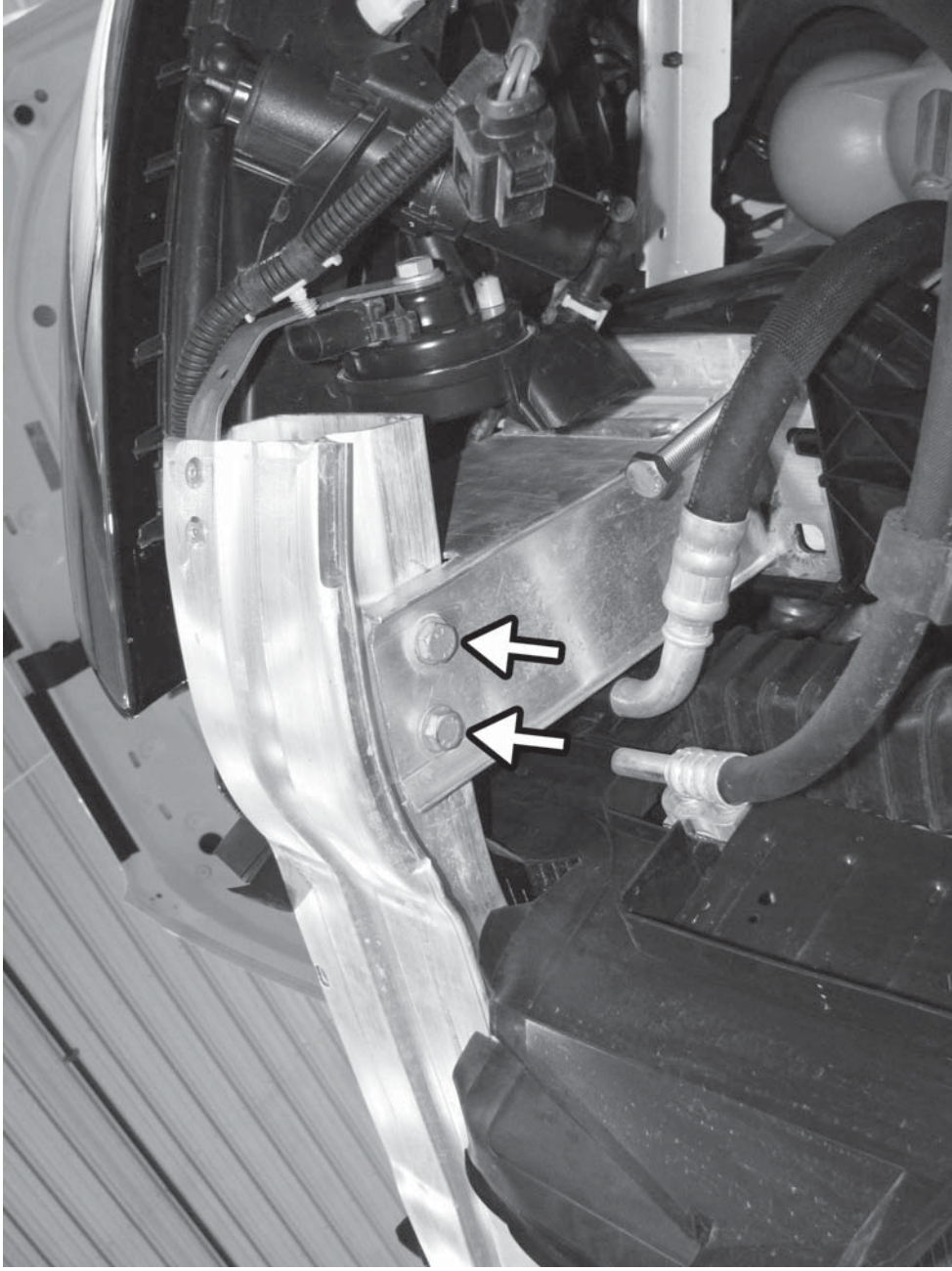

18) Unclick the hood latch cable junction box from the top of the radiator core support. Swing open the junction box and disconnect the hood cable.

Carefully pull the entire radiator core support forward to access the front of the engine. The core support will rest on the long screws previously installed.

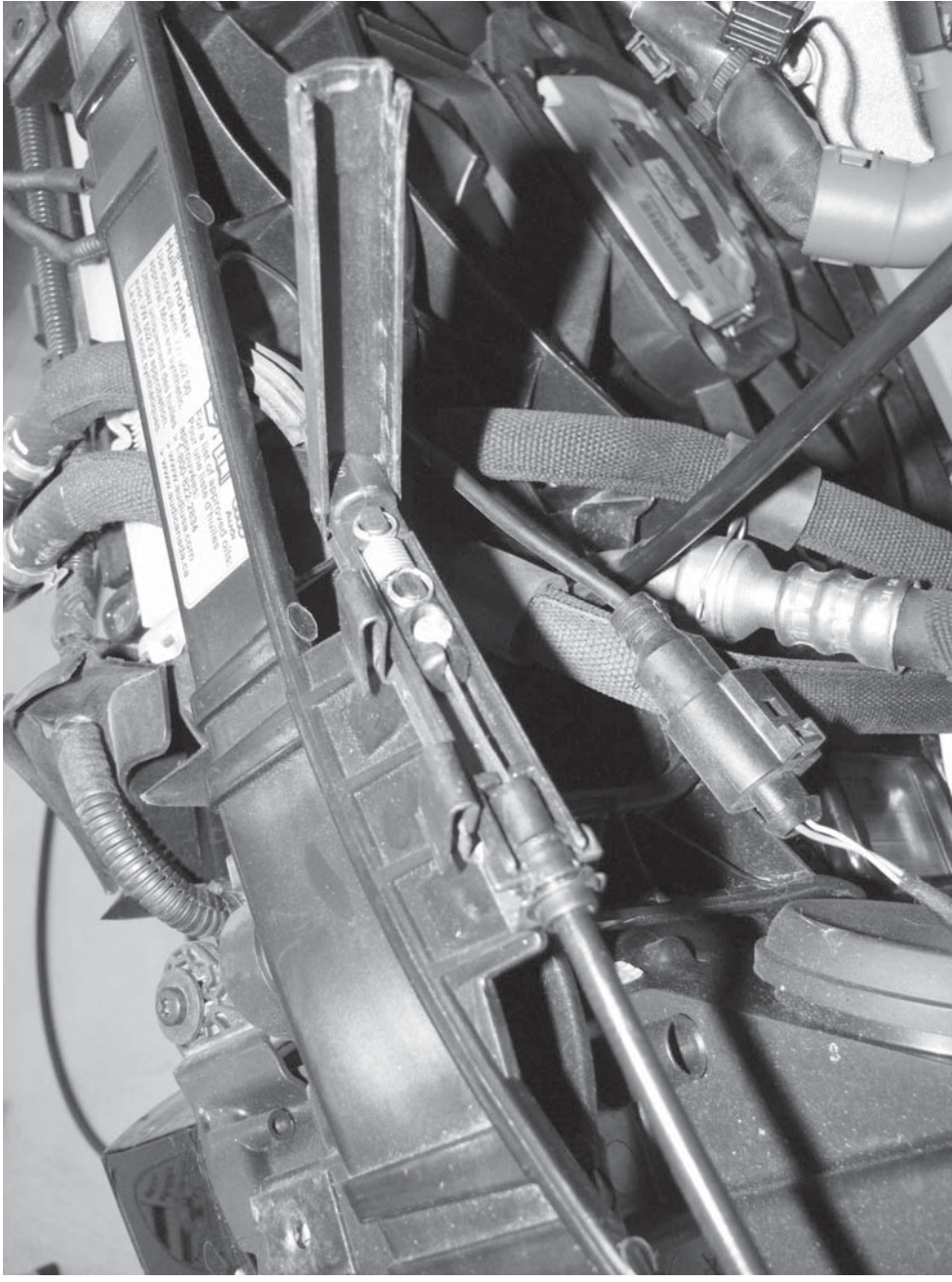

19) Remove the main upper engine cover by carefully lifting upwards. Remove the front engine cover by pulling the cover forward from the two upper mounts (pictured) and then lifting up out of the car.

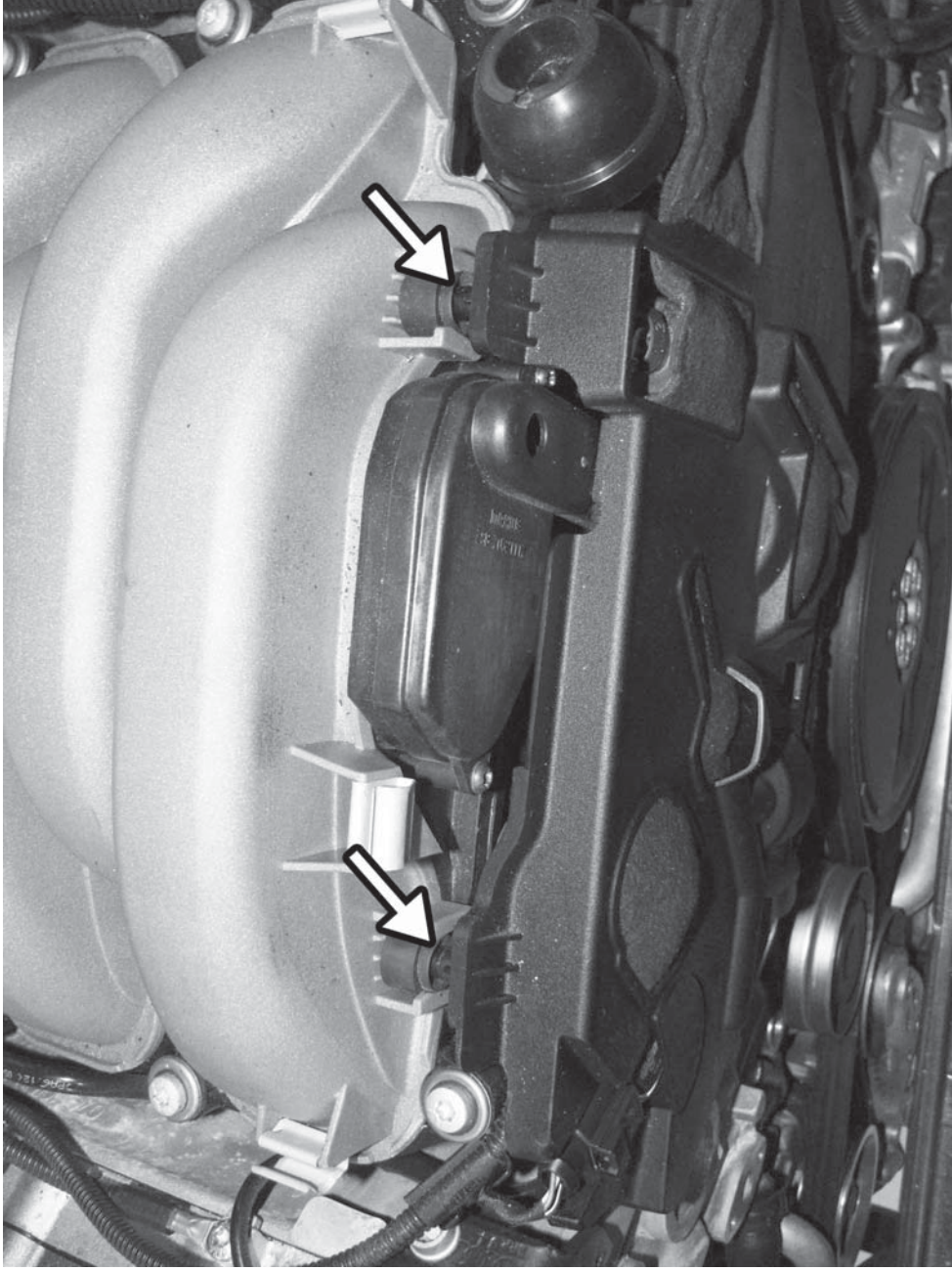

20) Remove the coolant reservoir cap. With a large drain pan, remove the T30 plug under the car to drain the engine coolant.

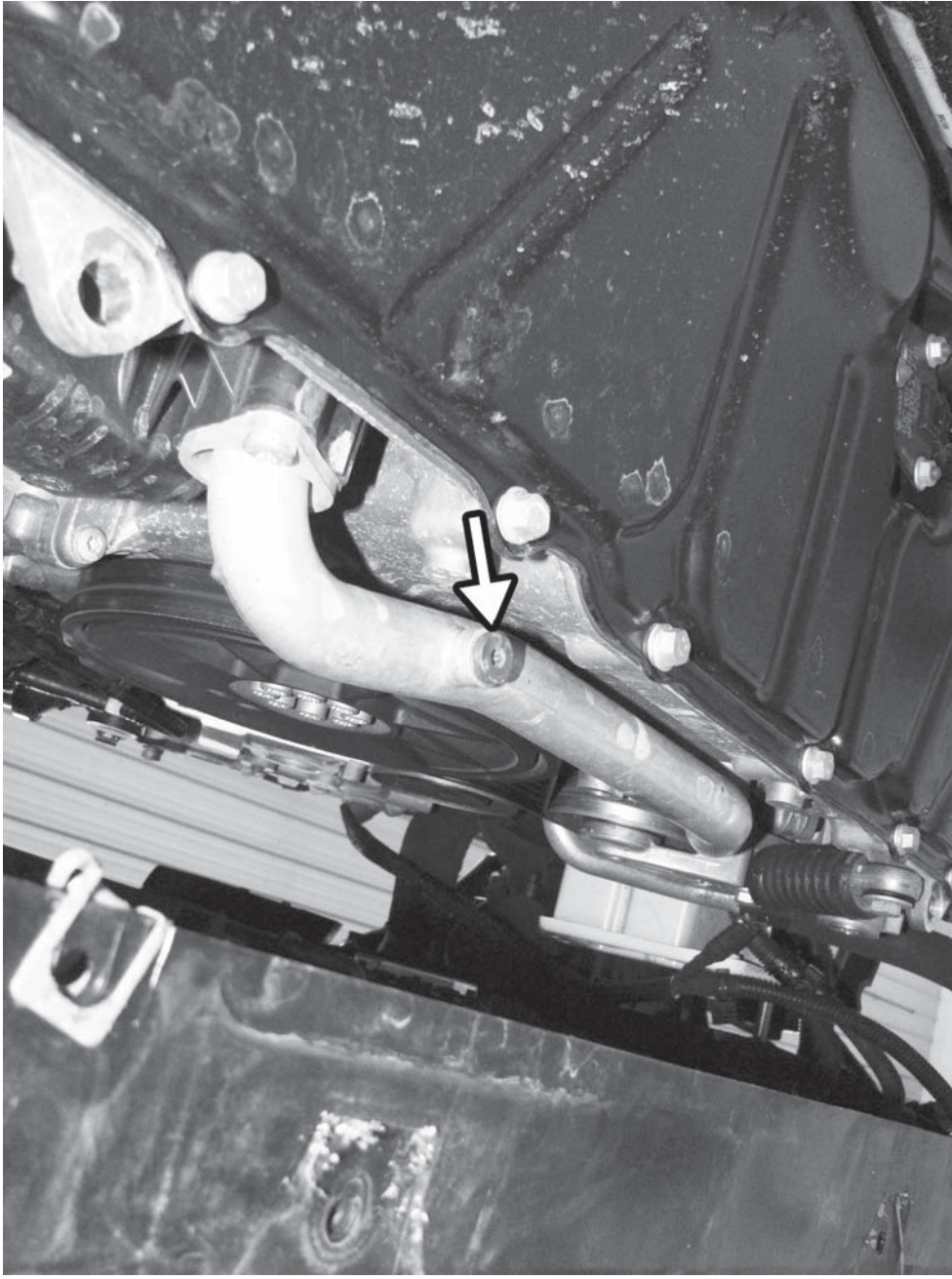

21) Unplug the electrical connector from the low pressure fuel sensor. Using several rags and 24mm wrench, slowly unscrew and remove the sensor to relieve fuel pressure in the car.

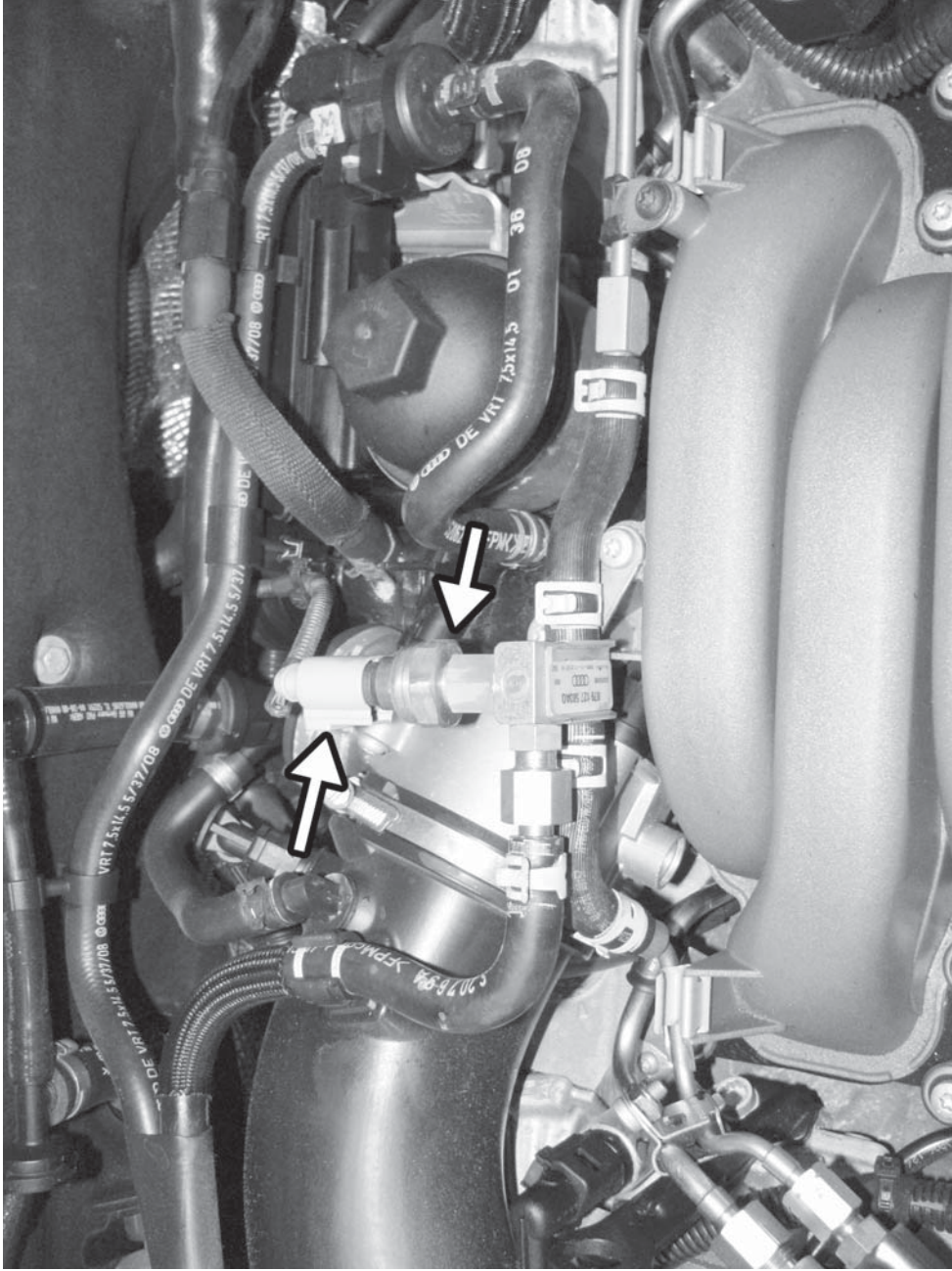

22) Unplug the electrical connector from the N80 valve. Unclamp and remove the vacuum line from the front of the valve. Finally, lift the valve off of its mounting location.

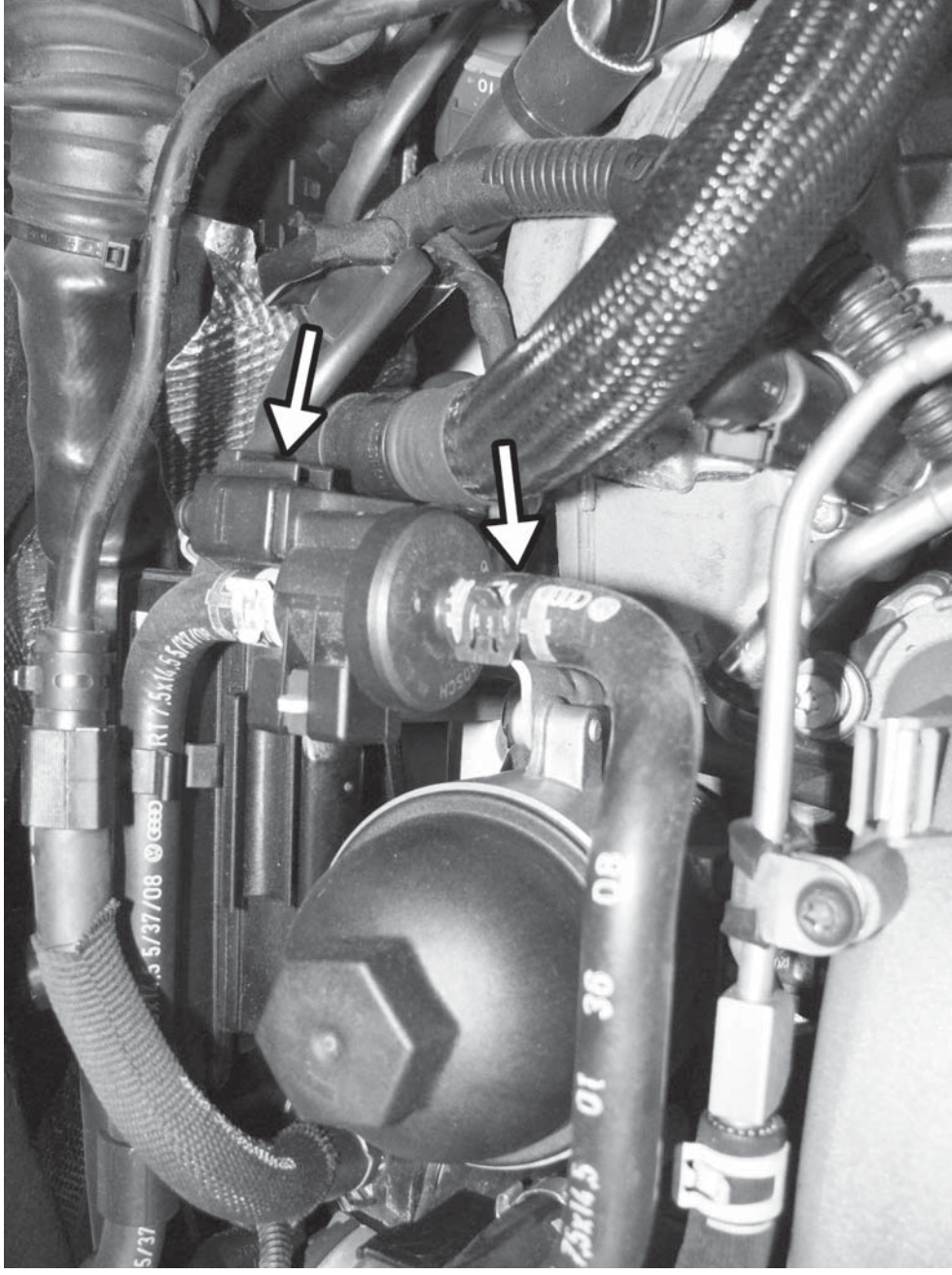

23) Remove the fuel line and N80 vacuum line connectors from the metal lines on the right side of the engine bay. Some residual fuel may spill from the lines.

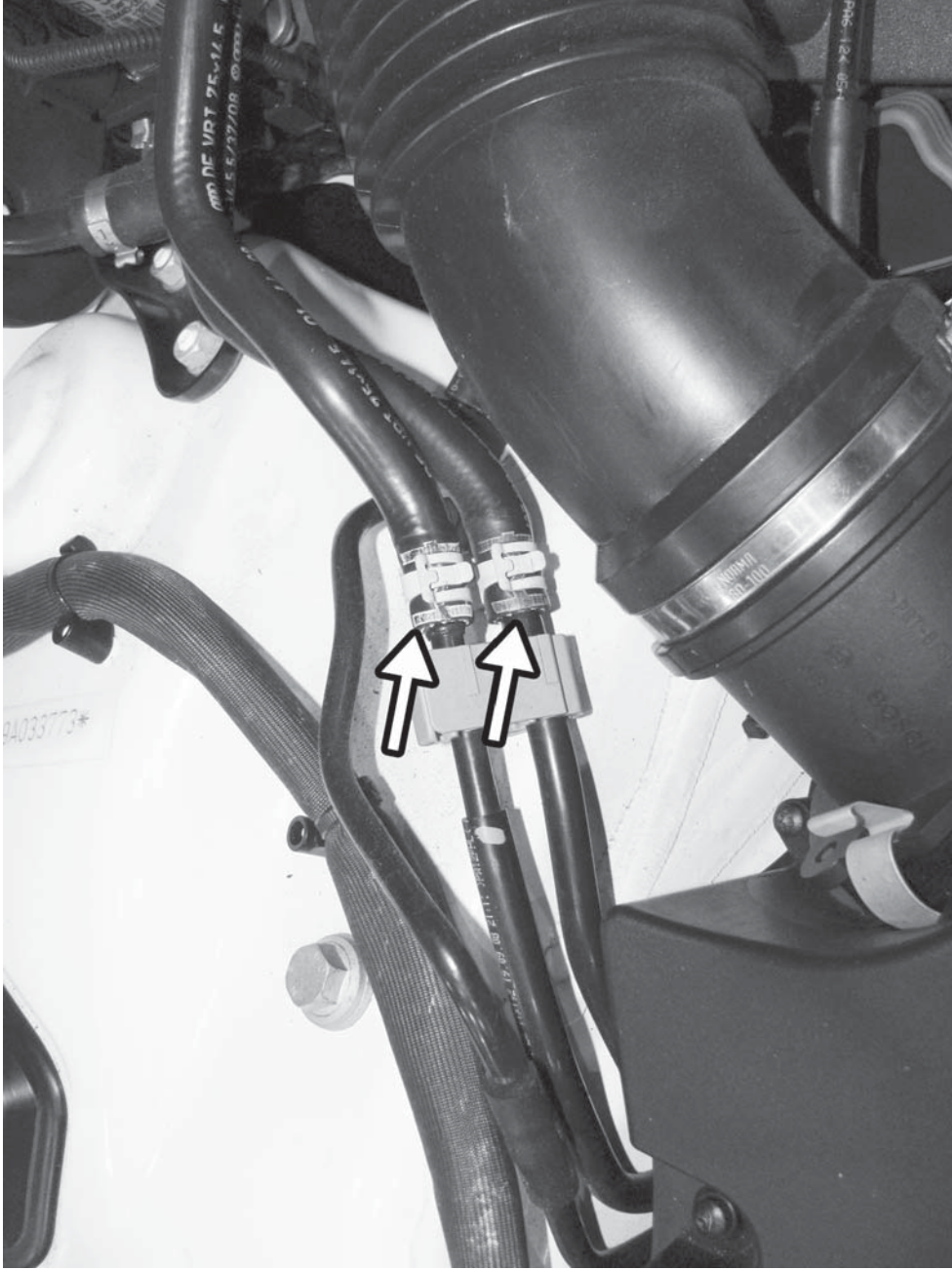

24) Remove the inlet hose from the engine by loosening the two large hose clamps on either end. Disconnect the rubber vacuum line, and the four way PCV connection.

Note: All four sides of the PCV connector must be removed at once. Use four small screwdrivers, wedging one on each side of the connector until sides all are free.

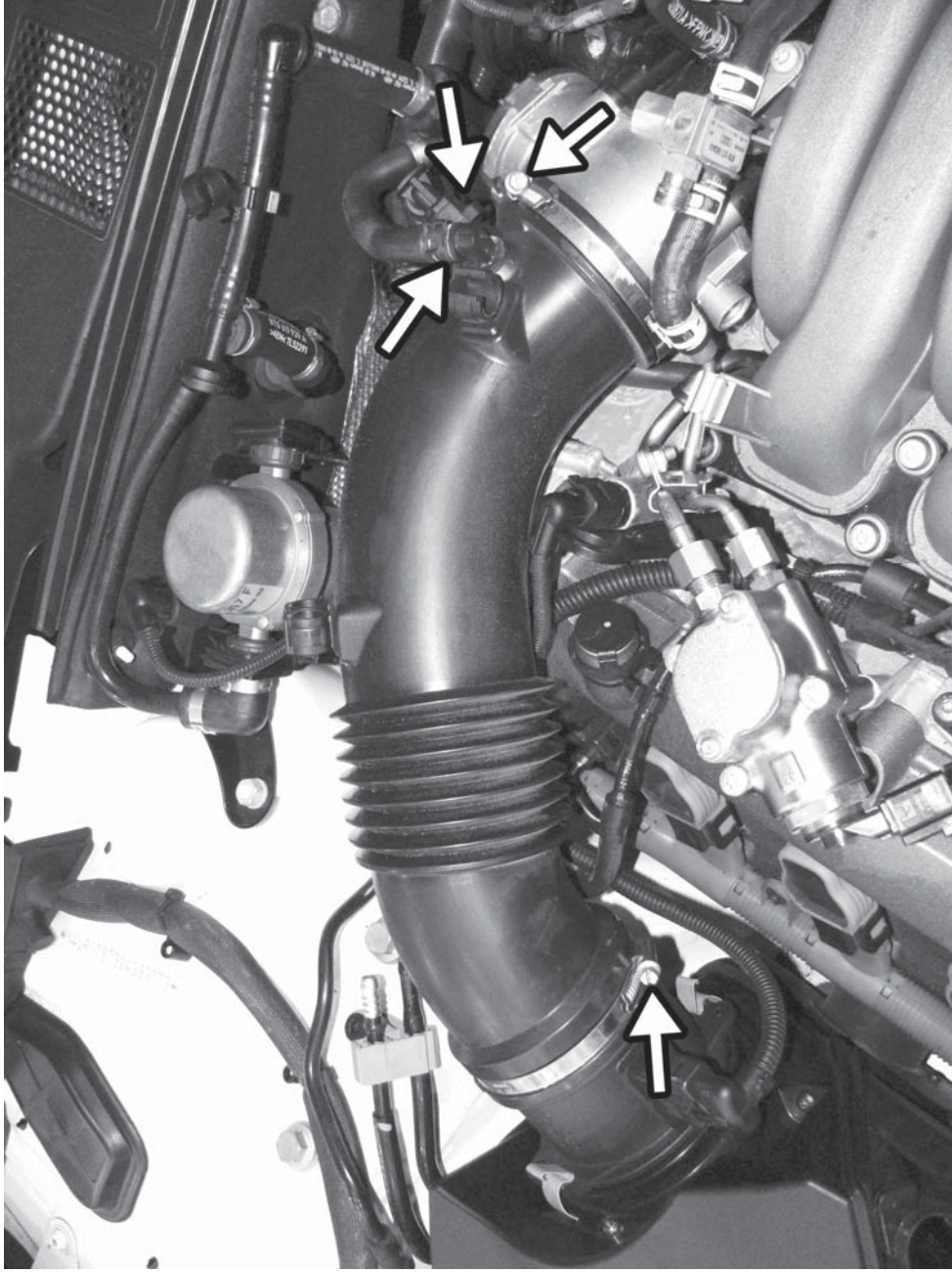

25) Disconnect the electrical connector to the throttle body, and then remove the four T30 screws. Remove the throttle body and carefully set aside.

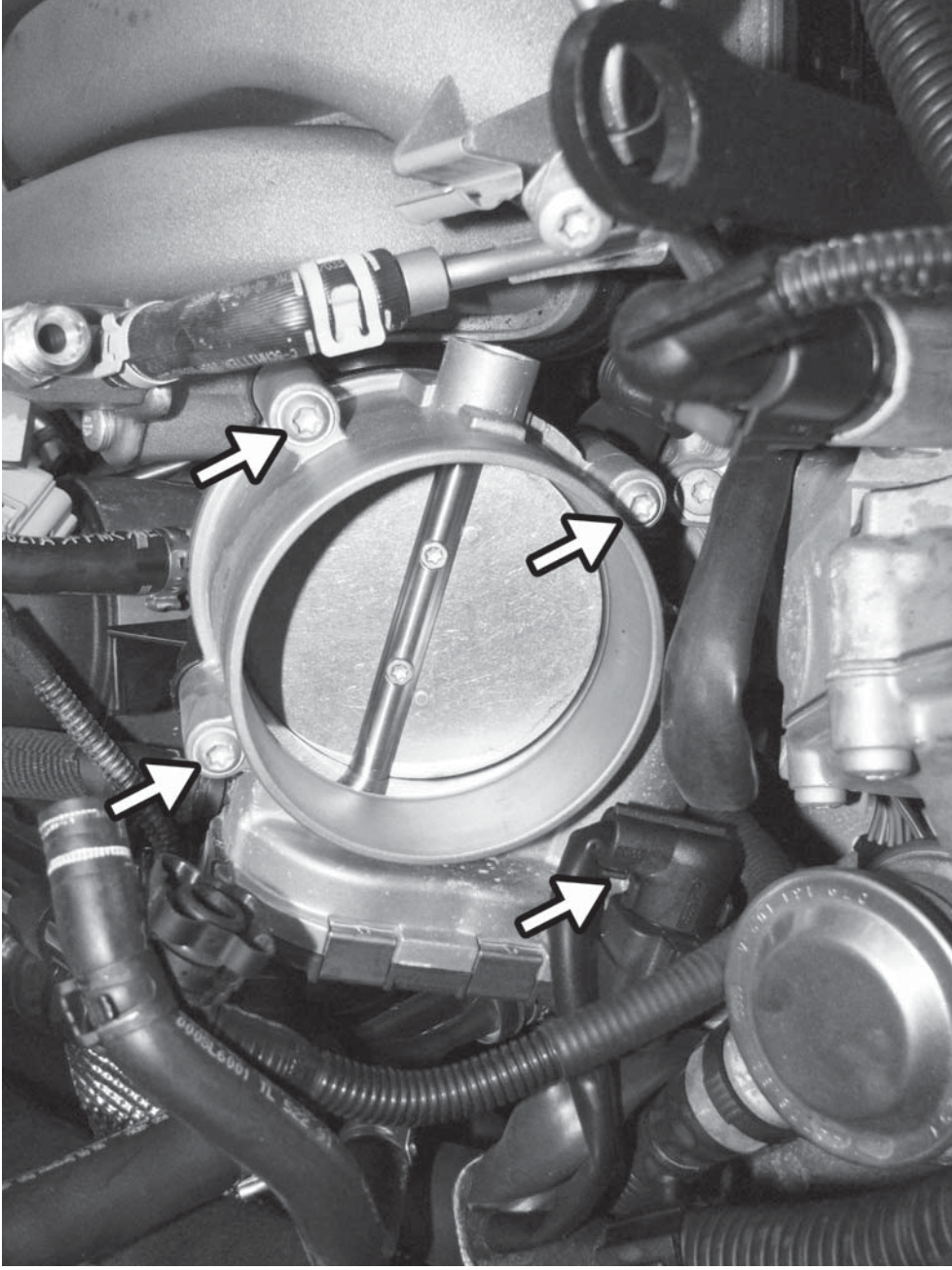

26) Disconnect the electrical connectors on both HPFP's. Disconnect all four fittings (two 14mm and two 17mm) on the pumps.

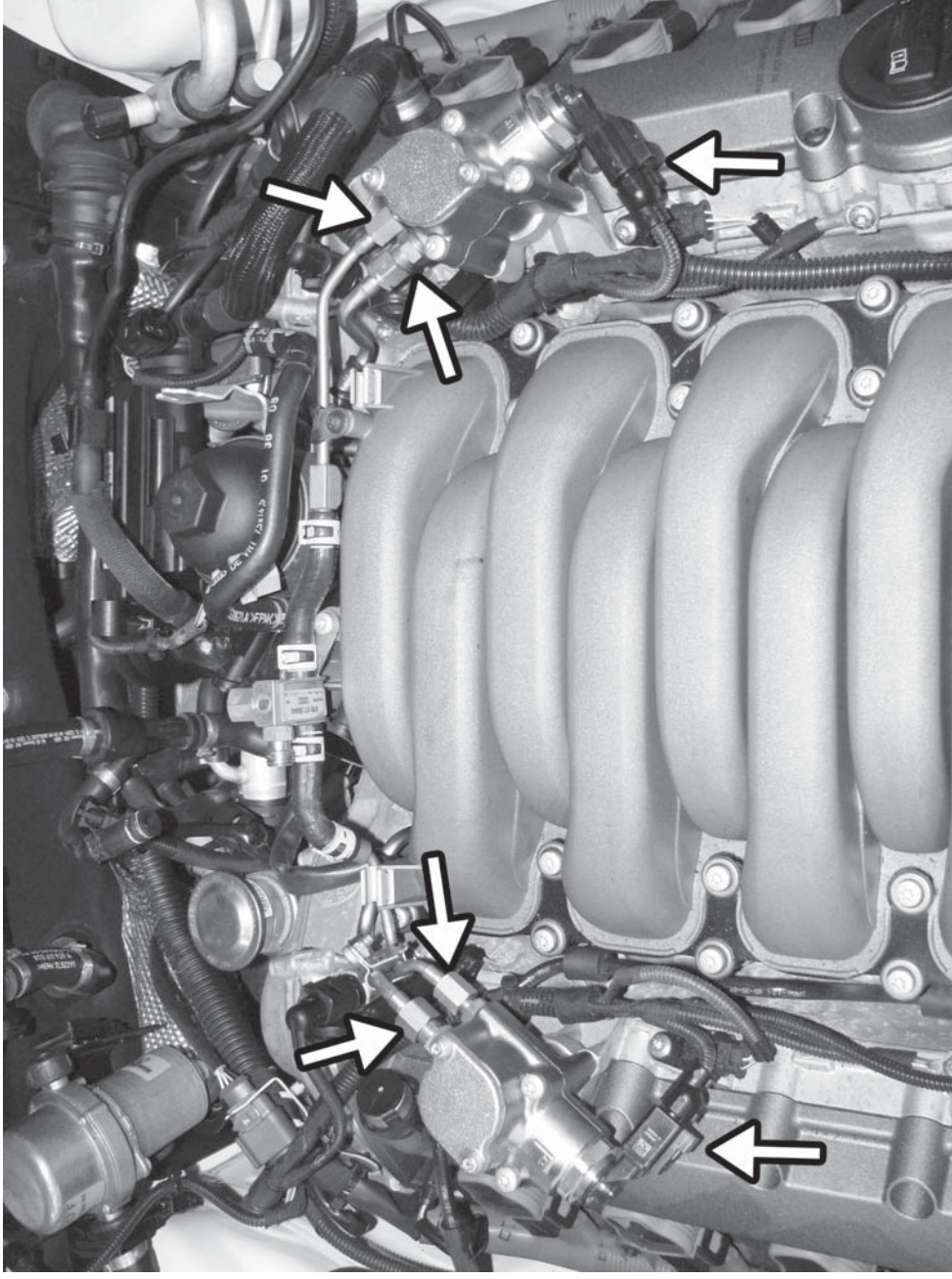

27) Disconnect the two T30 screws that hold the fuel lines in place to ease tension on the lines.

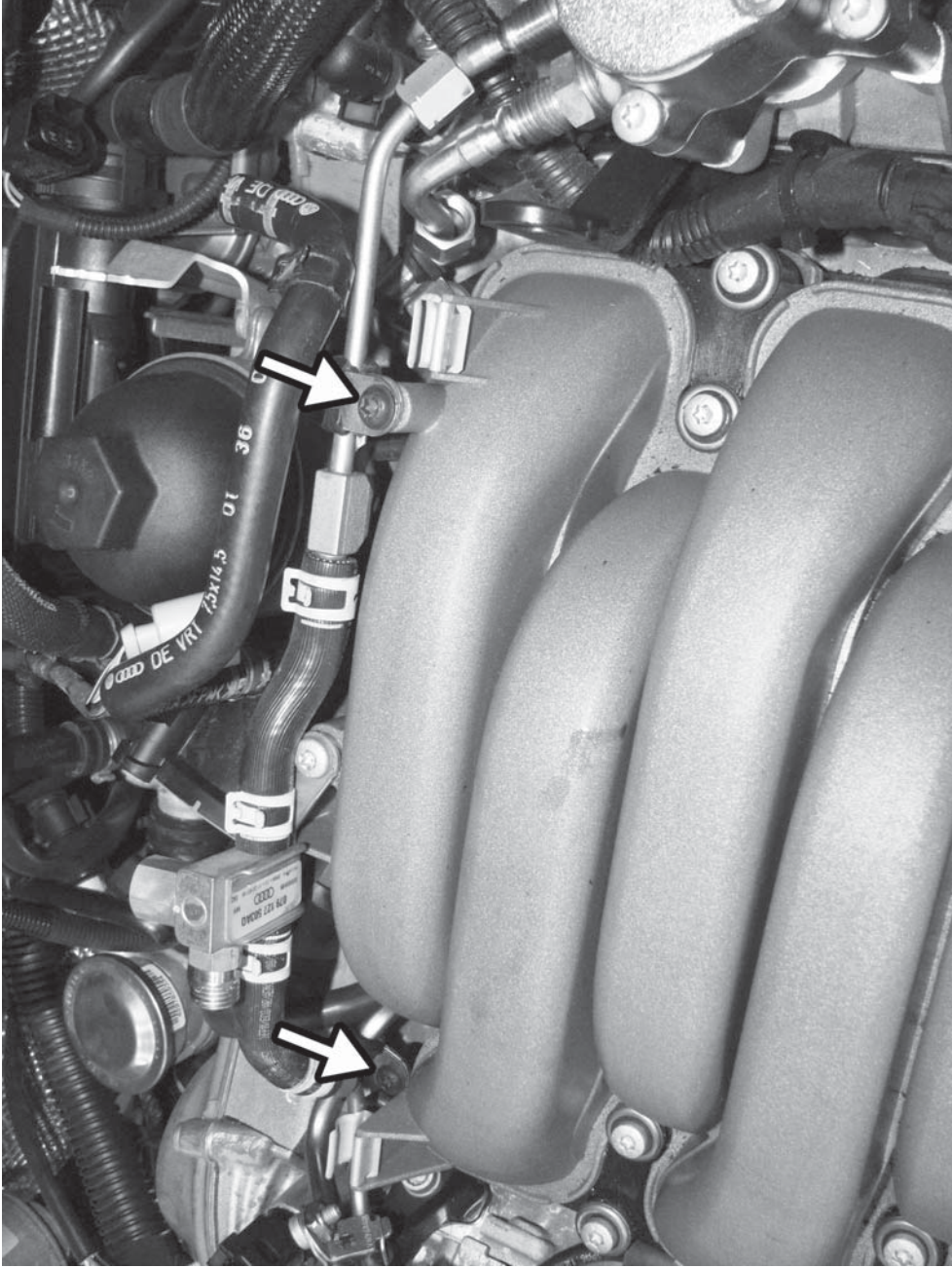

26) Loosen the two smaller, 14mm brass fittings (one fitting on each pump) that connected the smaller fuel lines to the pump.

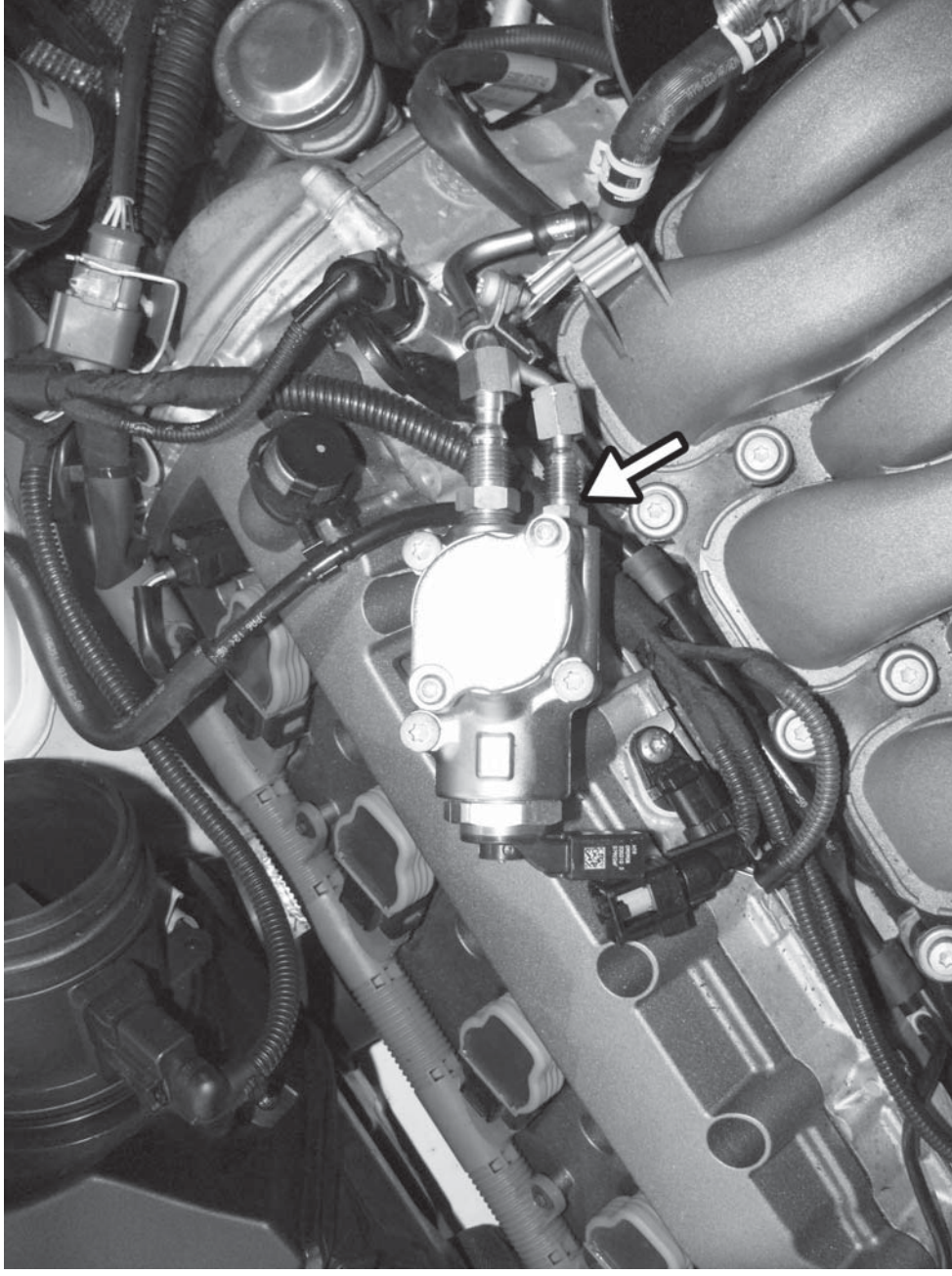

29) Remove the six (three on each side) T30 screws and remove both HPFP's. Once the pumps are removed, remove the previously loosened smaller brass fitting and the crush washer from inside the pump. Carefully set both pumps aside.

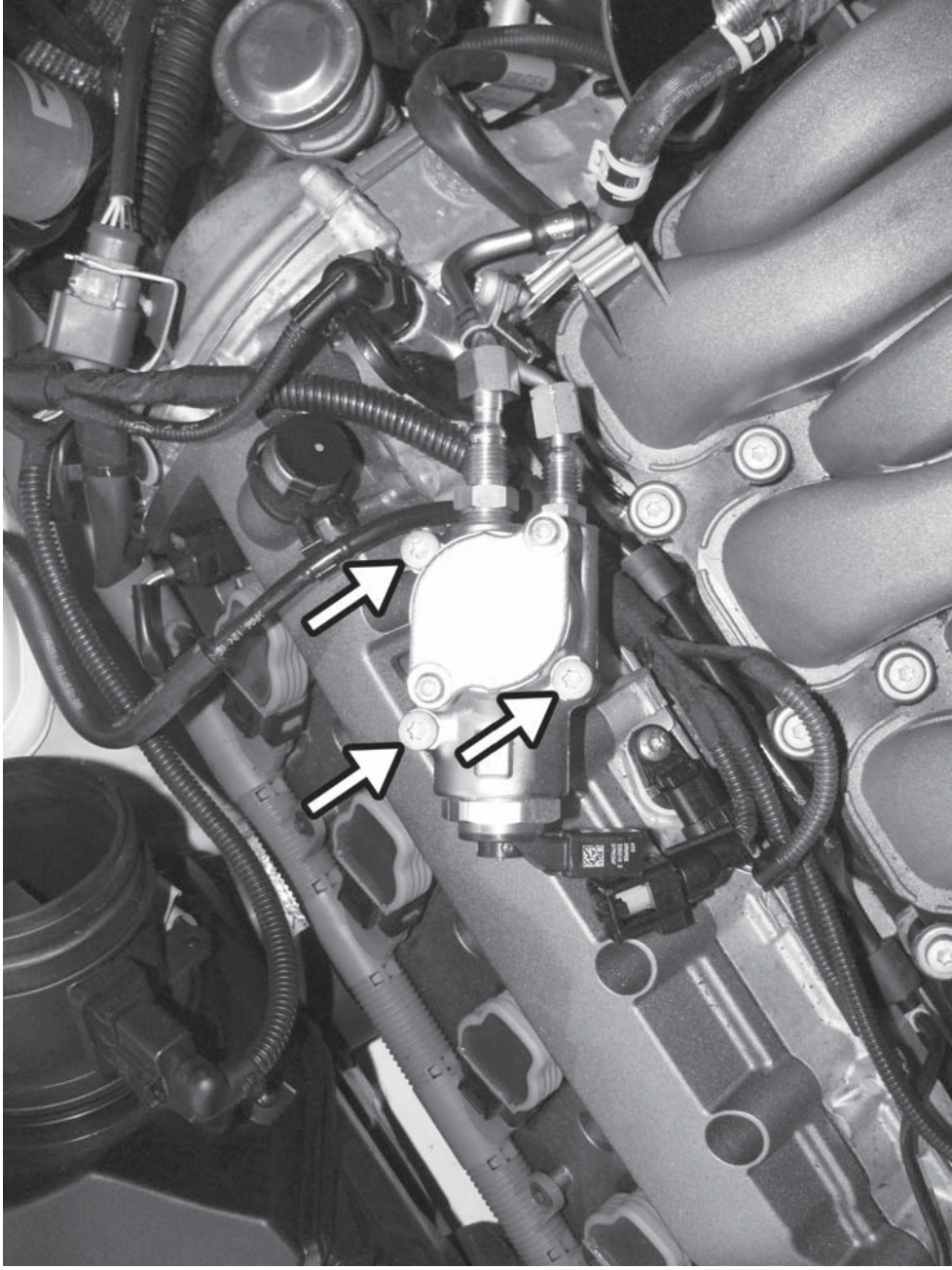

30) Remove the PCV line that runs between the left valve cover and the oil separator.

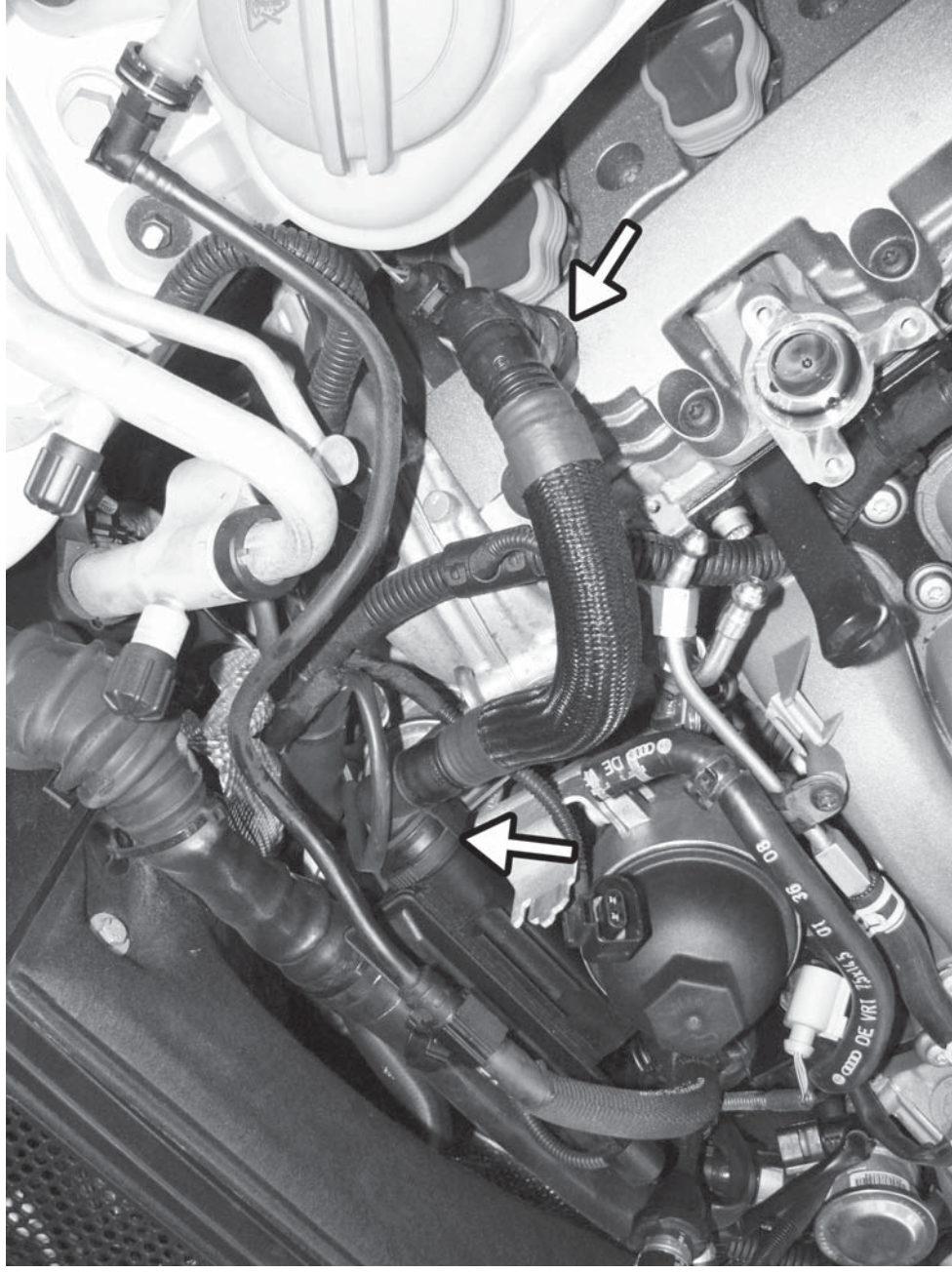

31) Remove the one T30 screw and remove the clamp from the fuel lines on the right side of the engine.

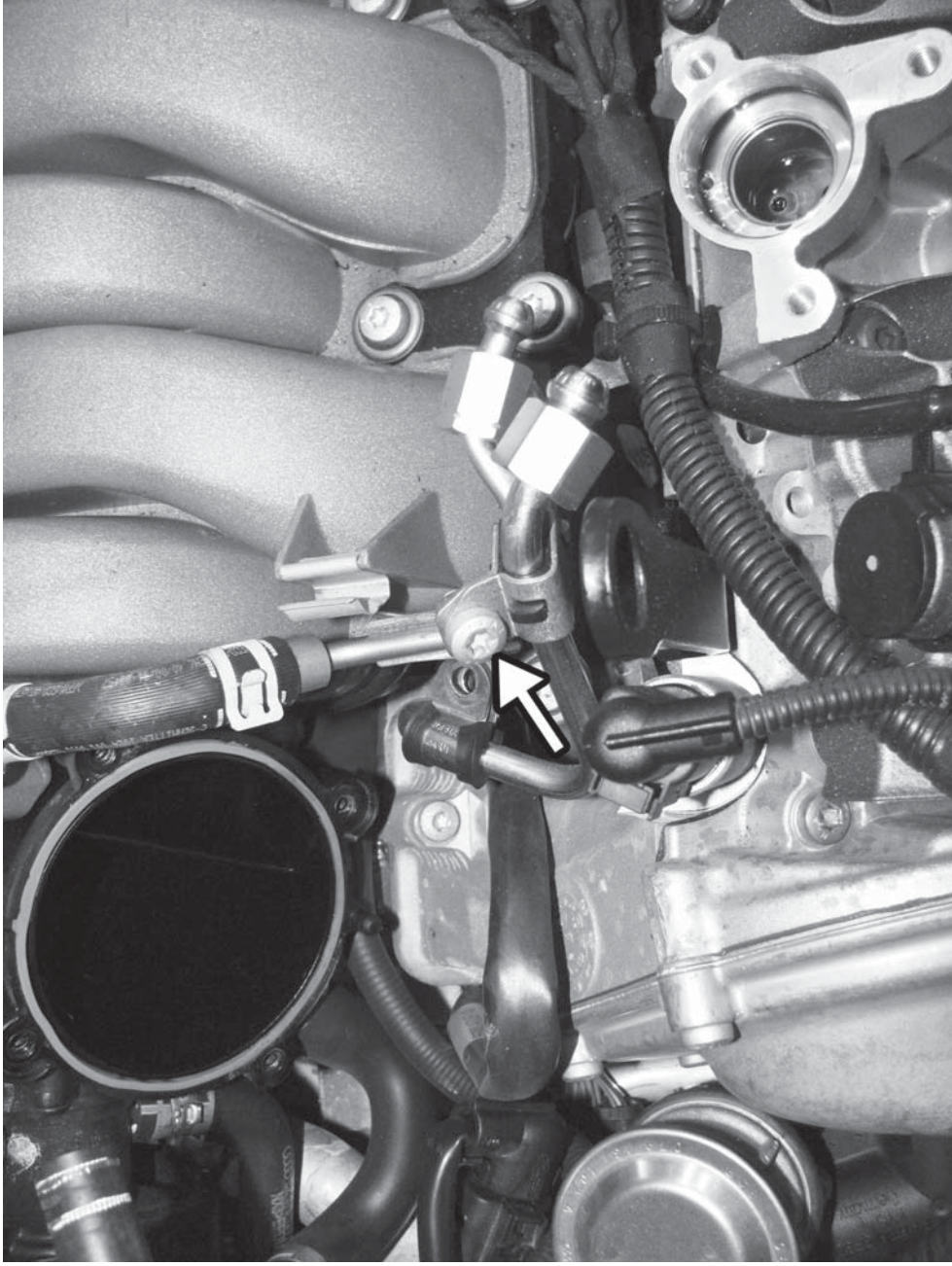

32) Remove the plastic clip from the low pressure fuel sensor wiring harness and lay the harness behind the engine.

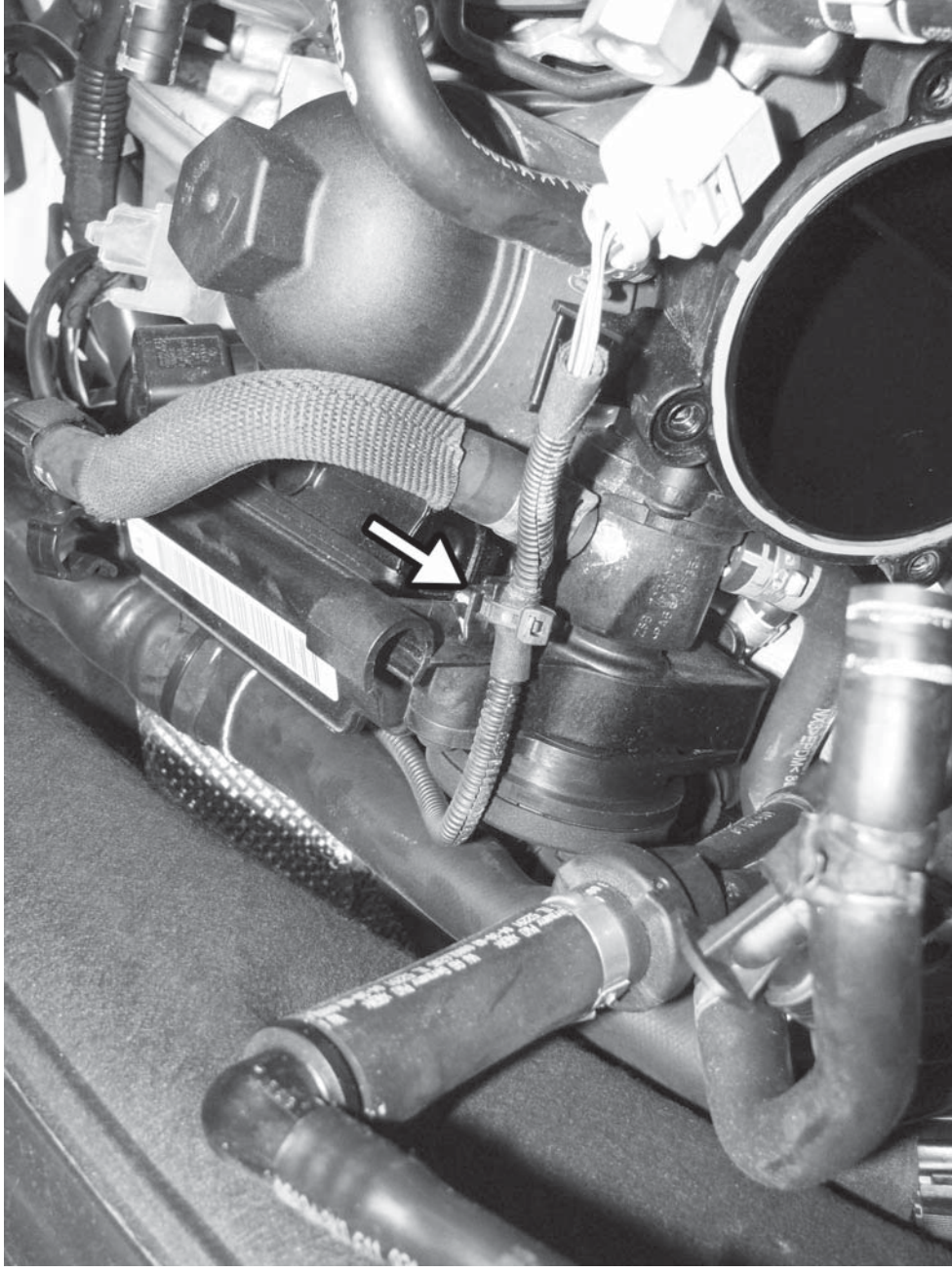

34) Carefully remove the plastic clip to the main engine wiring harness that connects the harness to the bracket behind the oil separator.

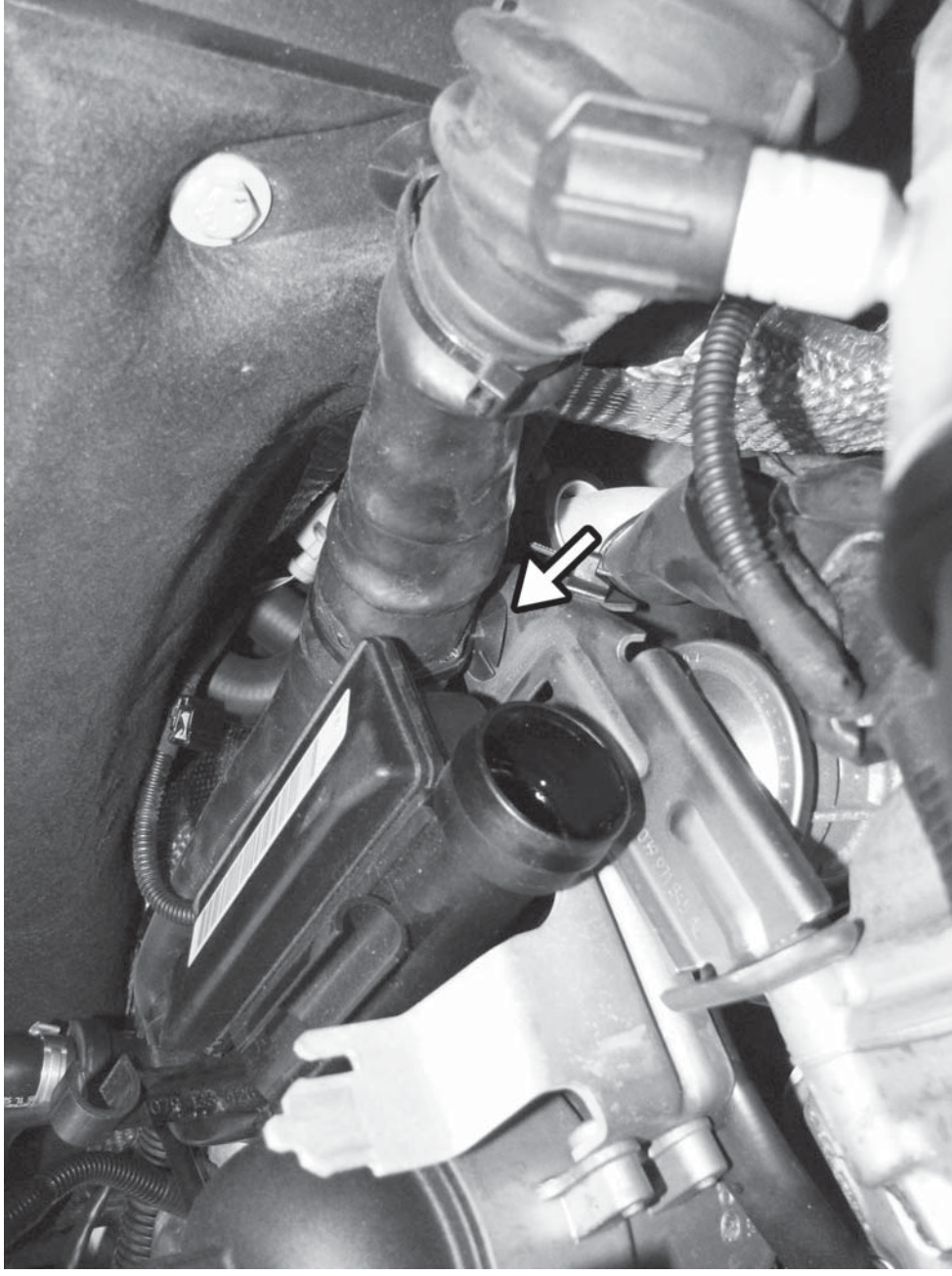

35) After manipulating the engine wiring harness down and back in the engine bay for clearance, remove the one T30 screw from the left side of the oil separator (as shown out of engine).

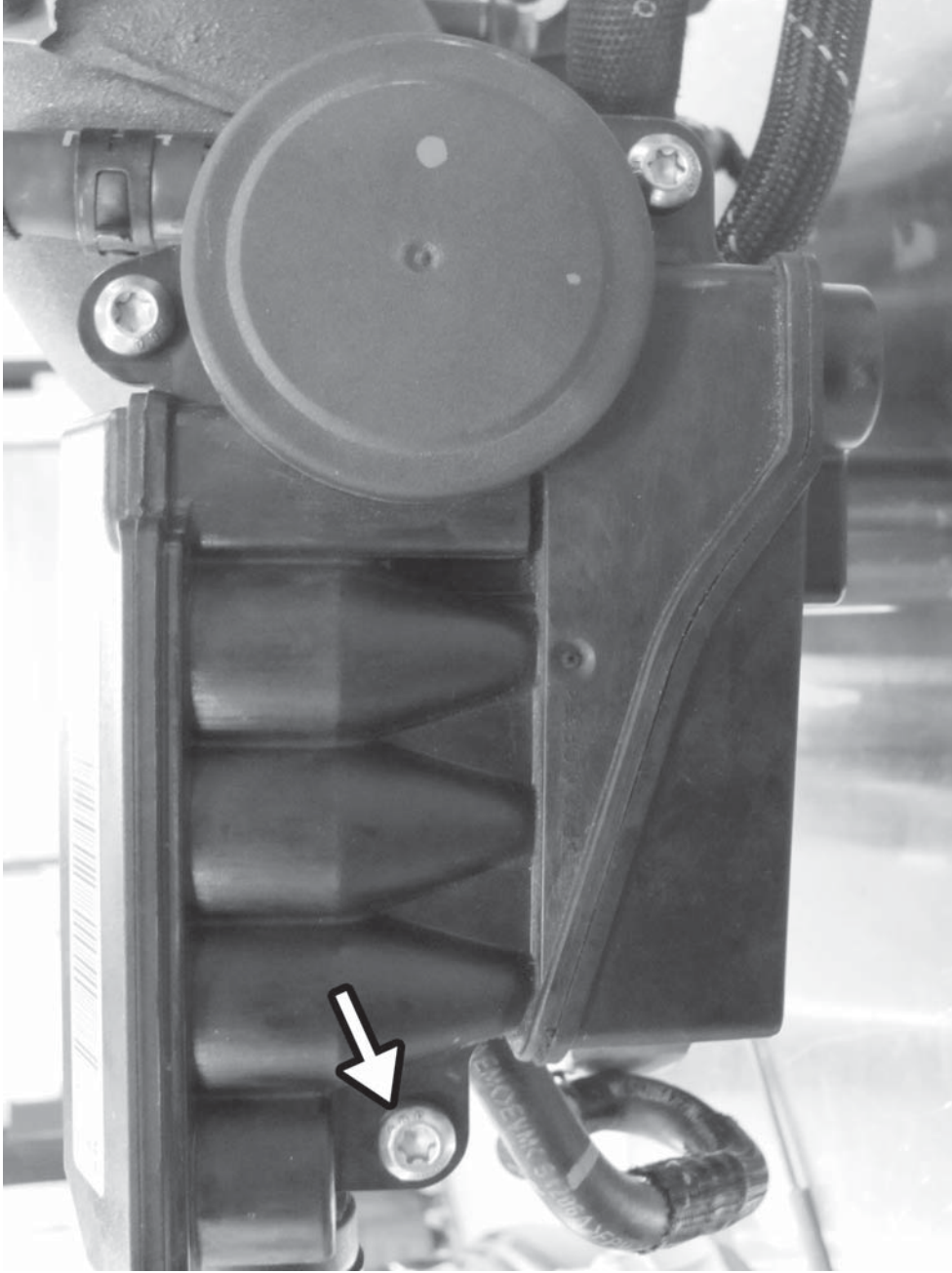

36) Remove the three electrical connectors from the front upper wiring harness. Two are on the front of the engine, and one is on the right cylinder head.

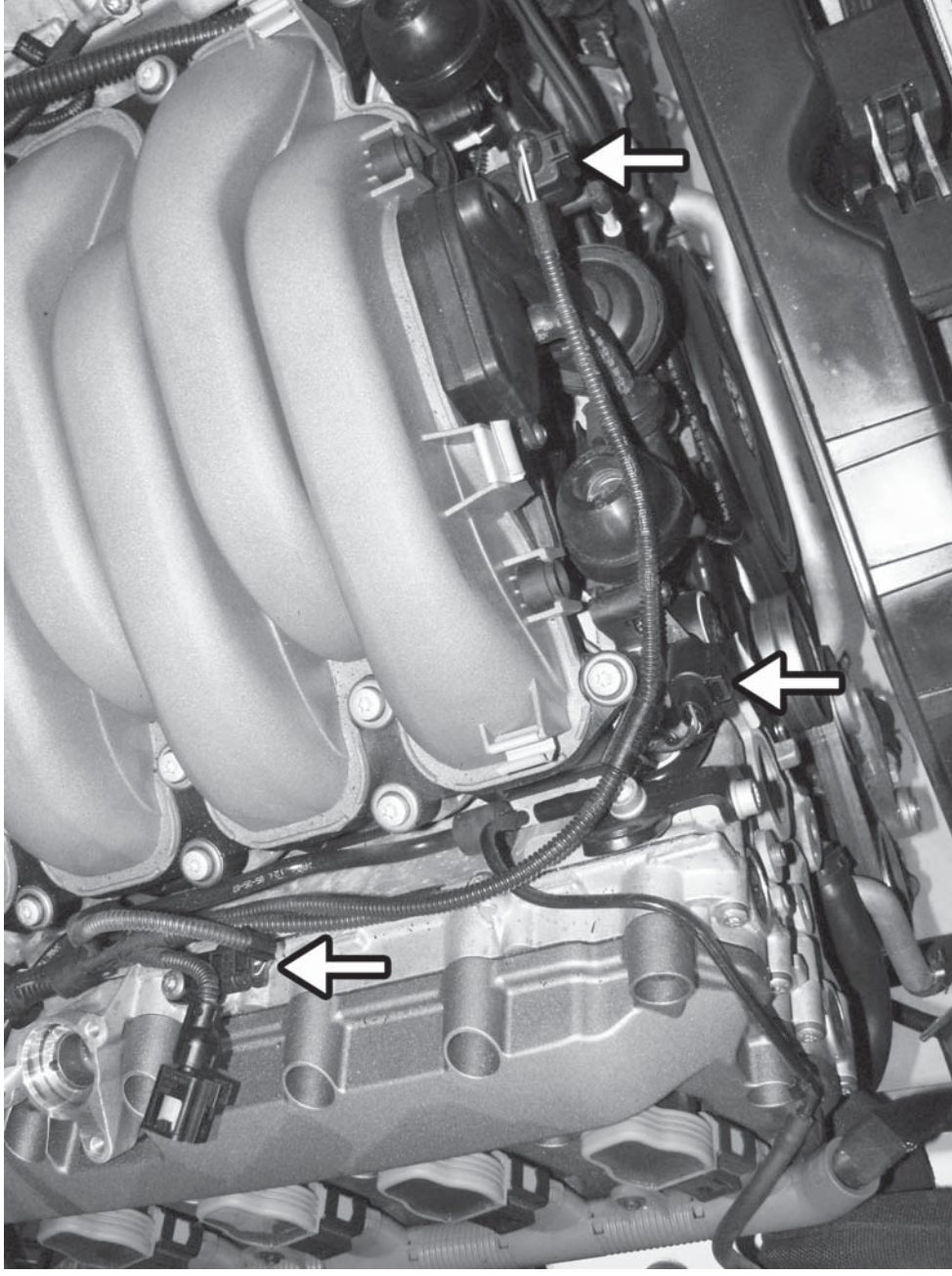

37) Disconnect the electrical connector from the left runner flap sensor.

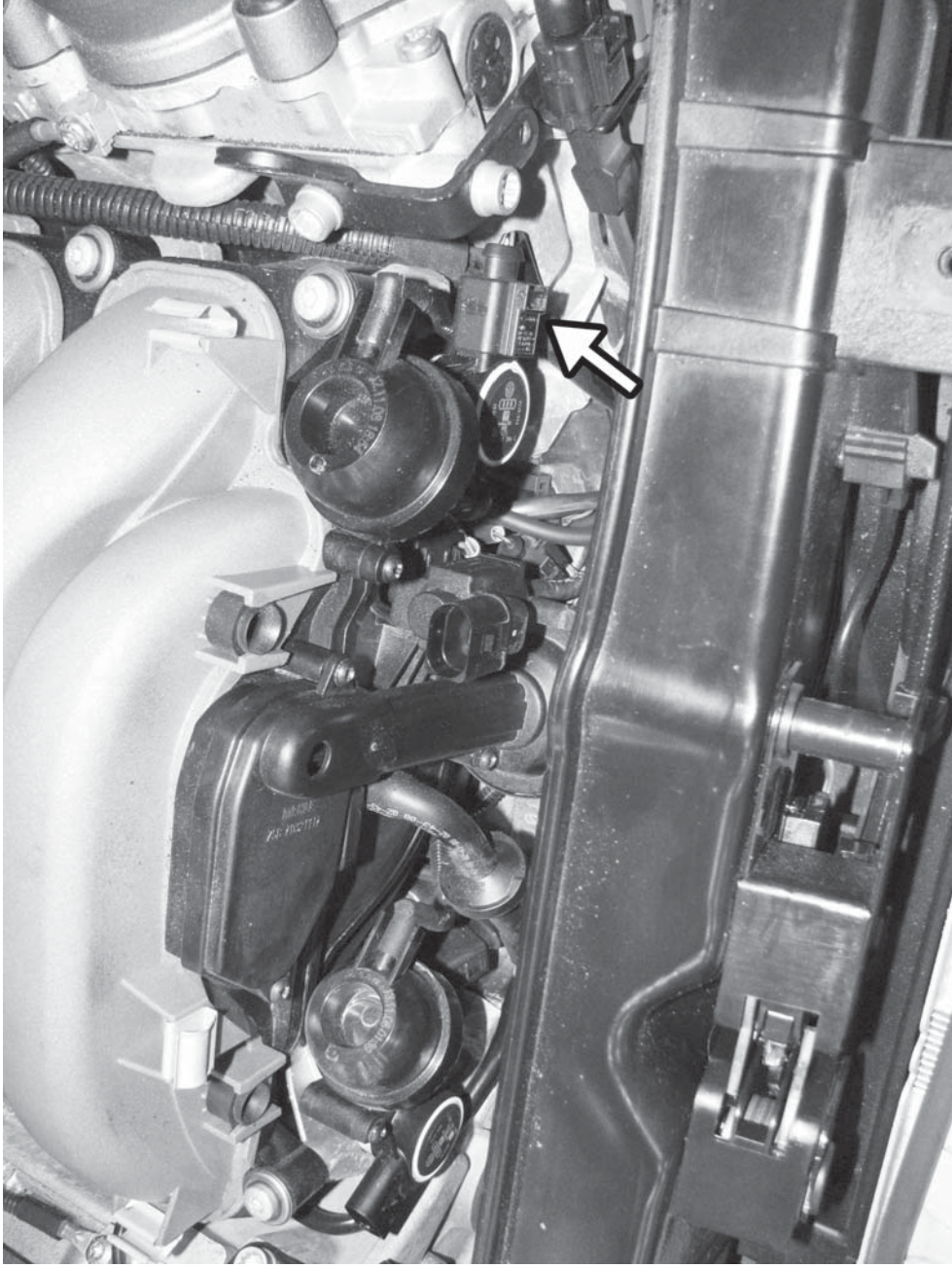

38) Disconnect the three vacuum lines from the front of the intake manifold.

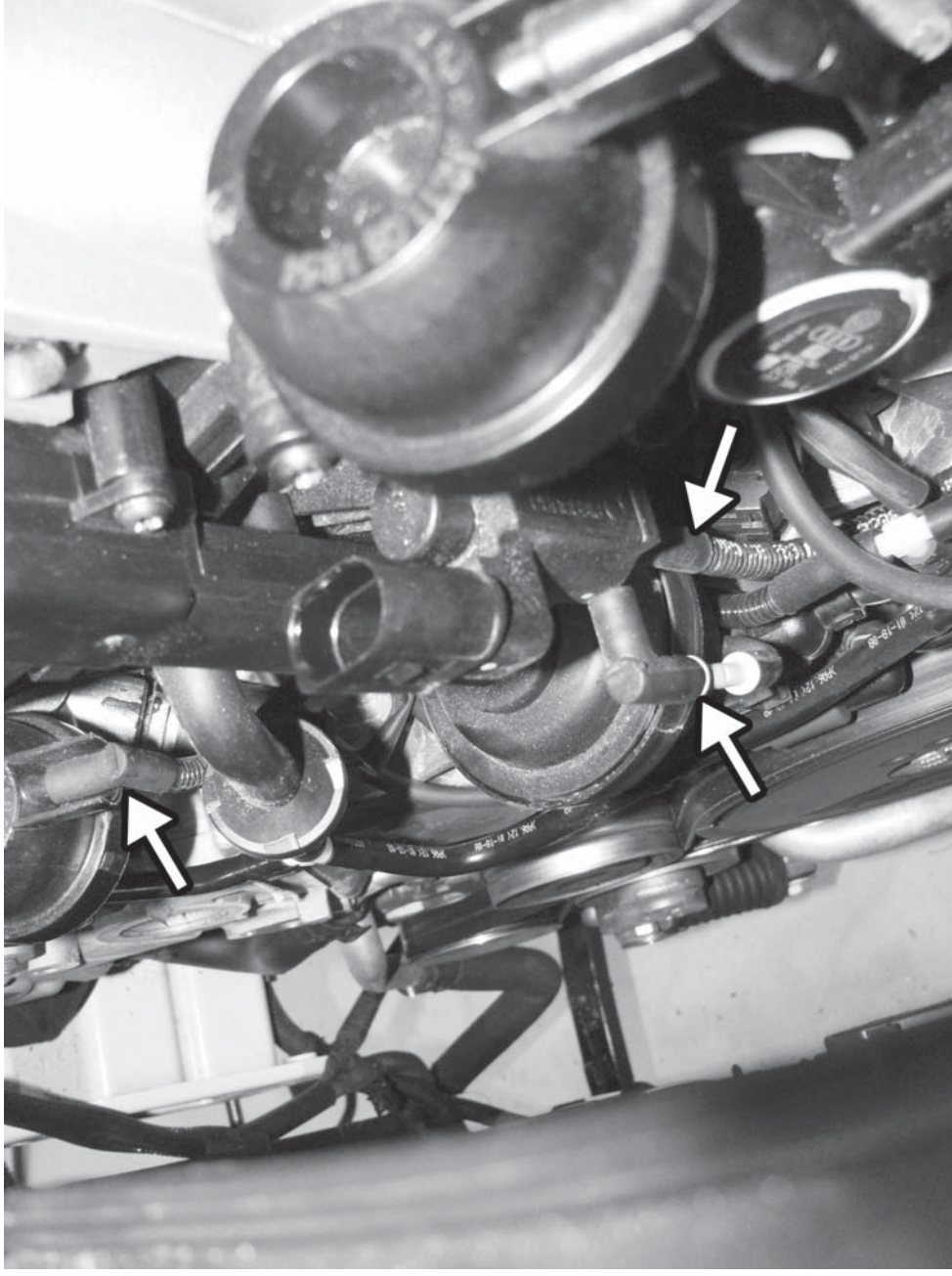

39) Disconnect the two vacuum lines from each of the runner flap actuators on the intake manifold.

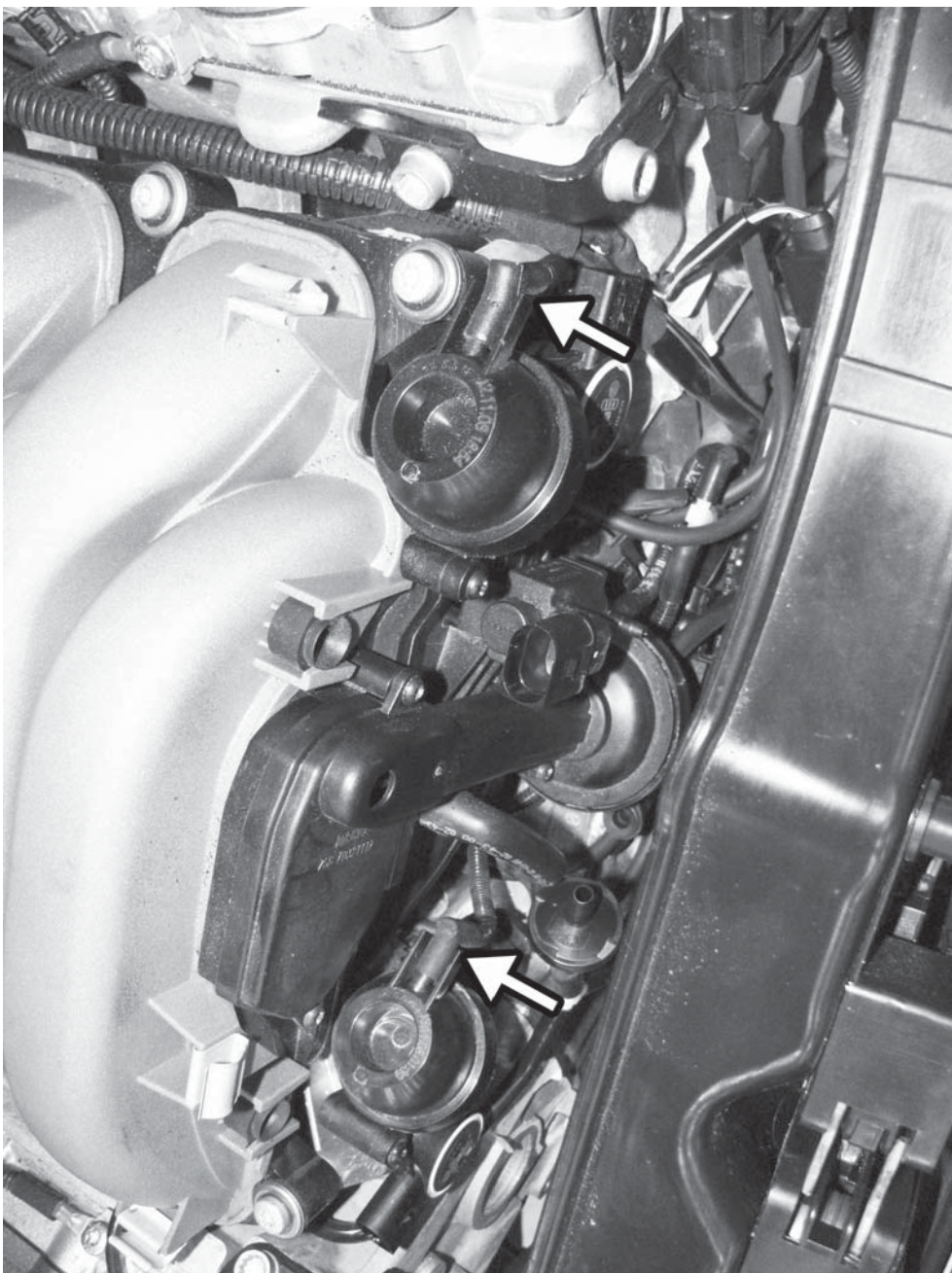

40) Clean any excess debris from around the intake manifold to prevent dirt from falling down in the intake.

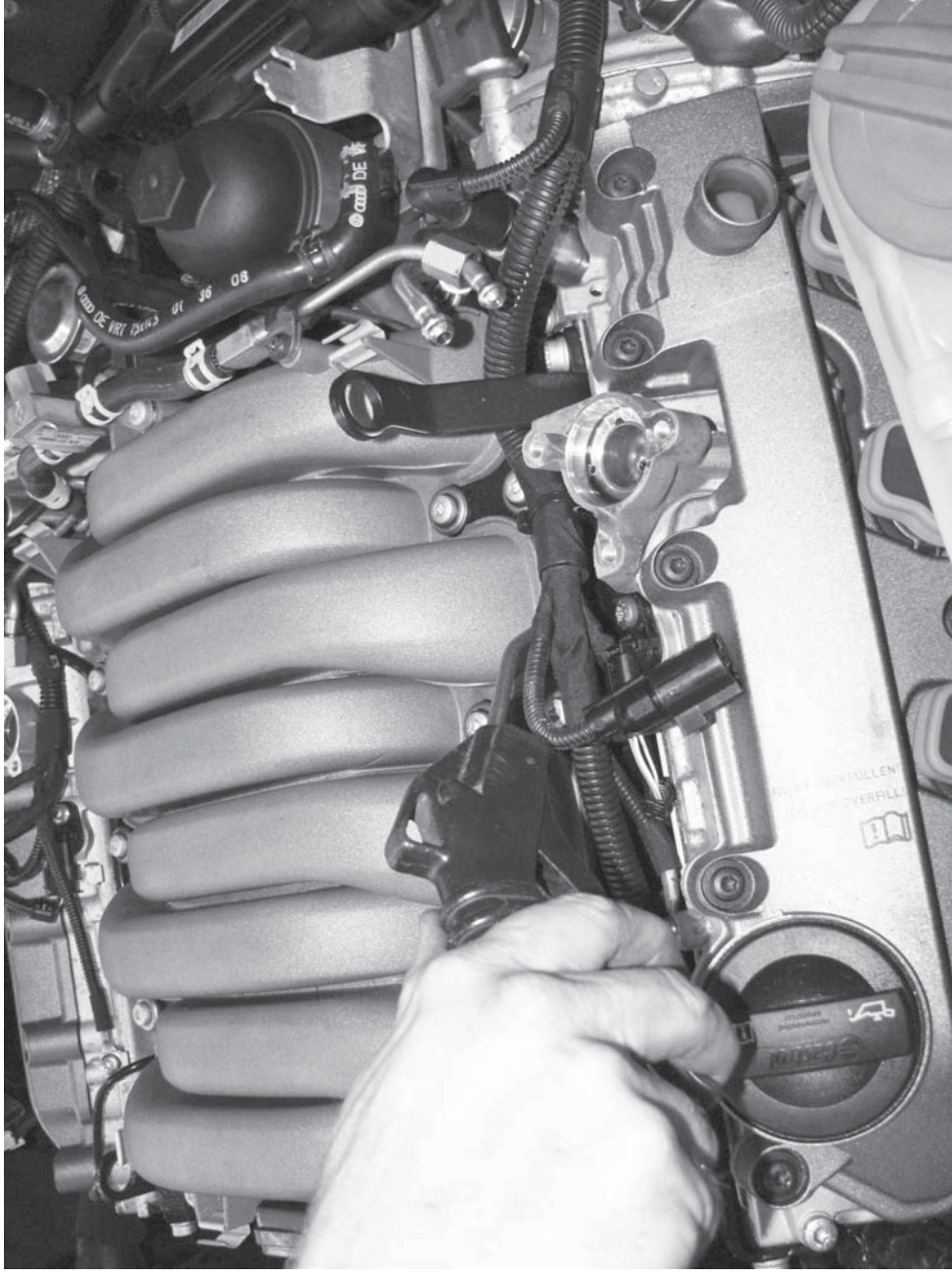

41) Remove the fifteen remaining T30 screws that hold the upper part of the intake manifold in place.

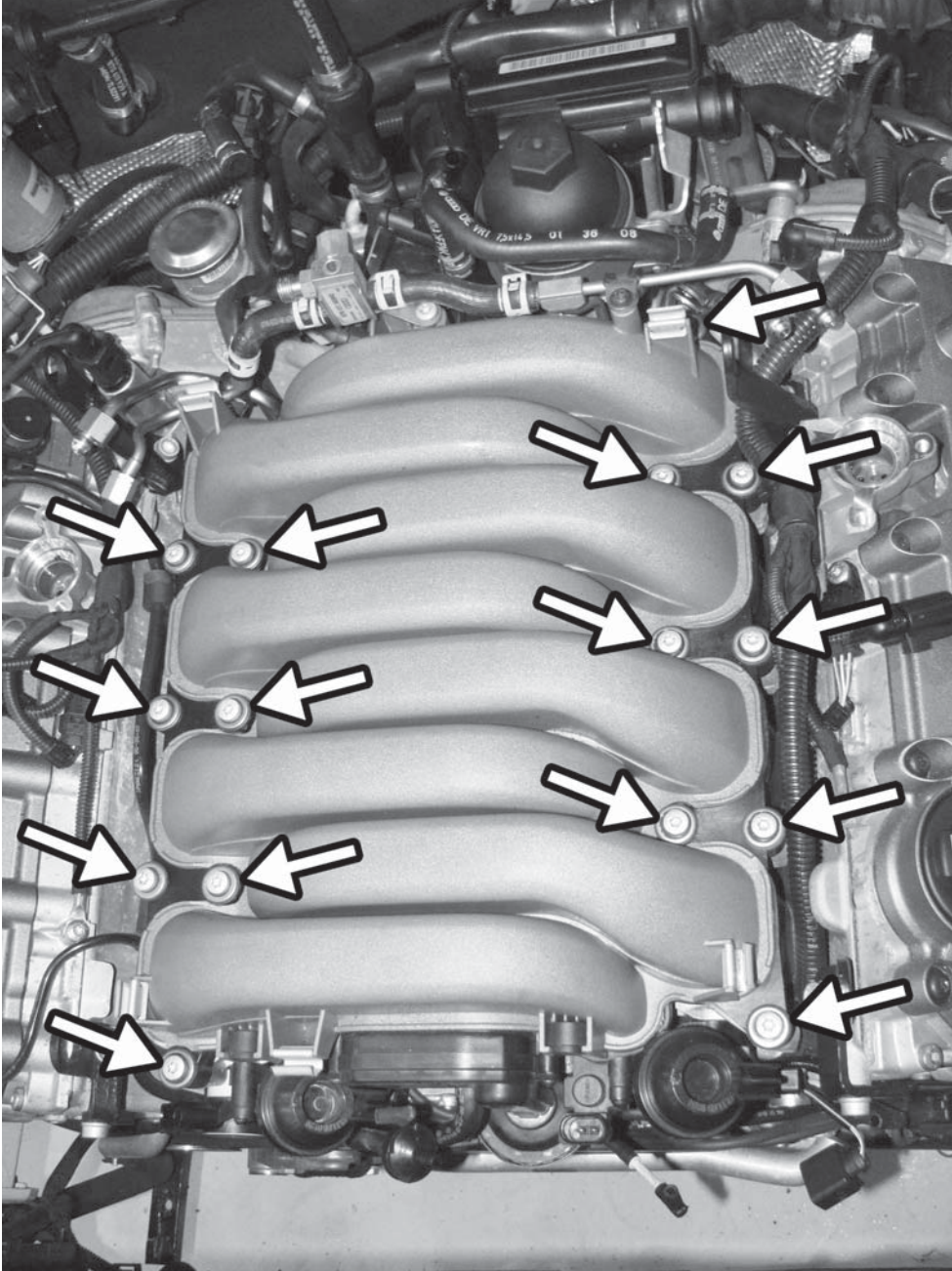

42) Remove the three T30 screws holding the fuel line on the back of the manifold in place. Remove the hose clamp and disconnect the hose from the right side of the manifold and remove the fuel line assembly.

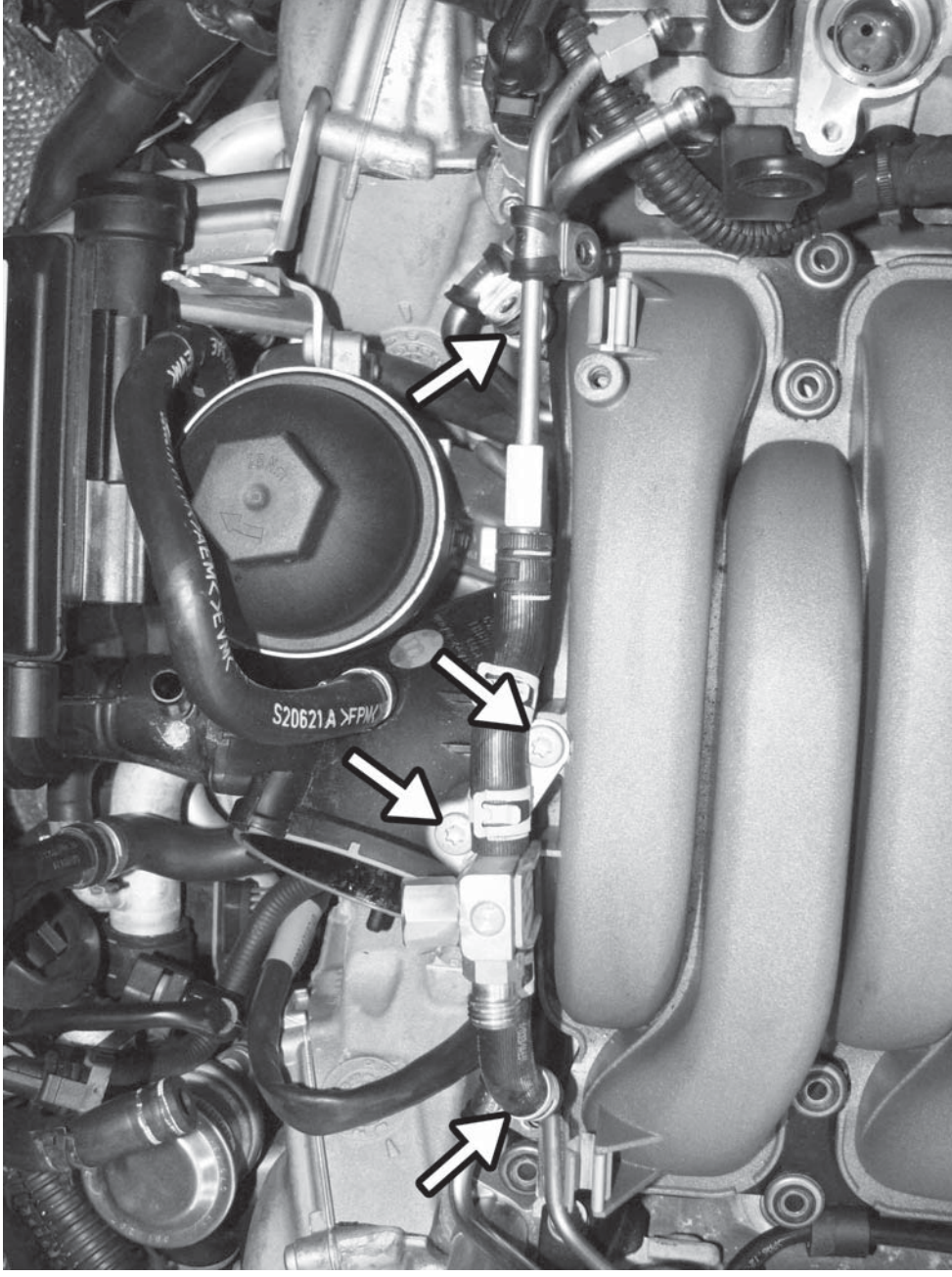

43) Carefully lift the intake manifold upwards from the engine, tilting the front and right sides upwards. There are still three lines connected to the manifold that must be removed before the manifold will come off.

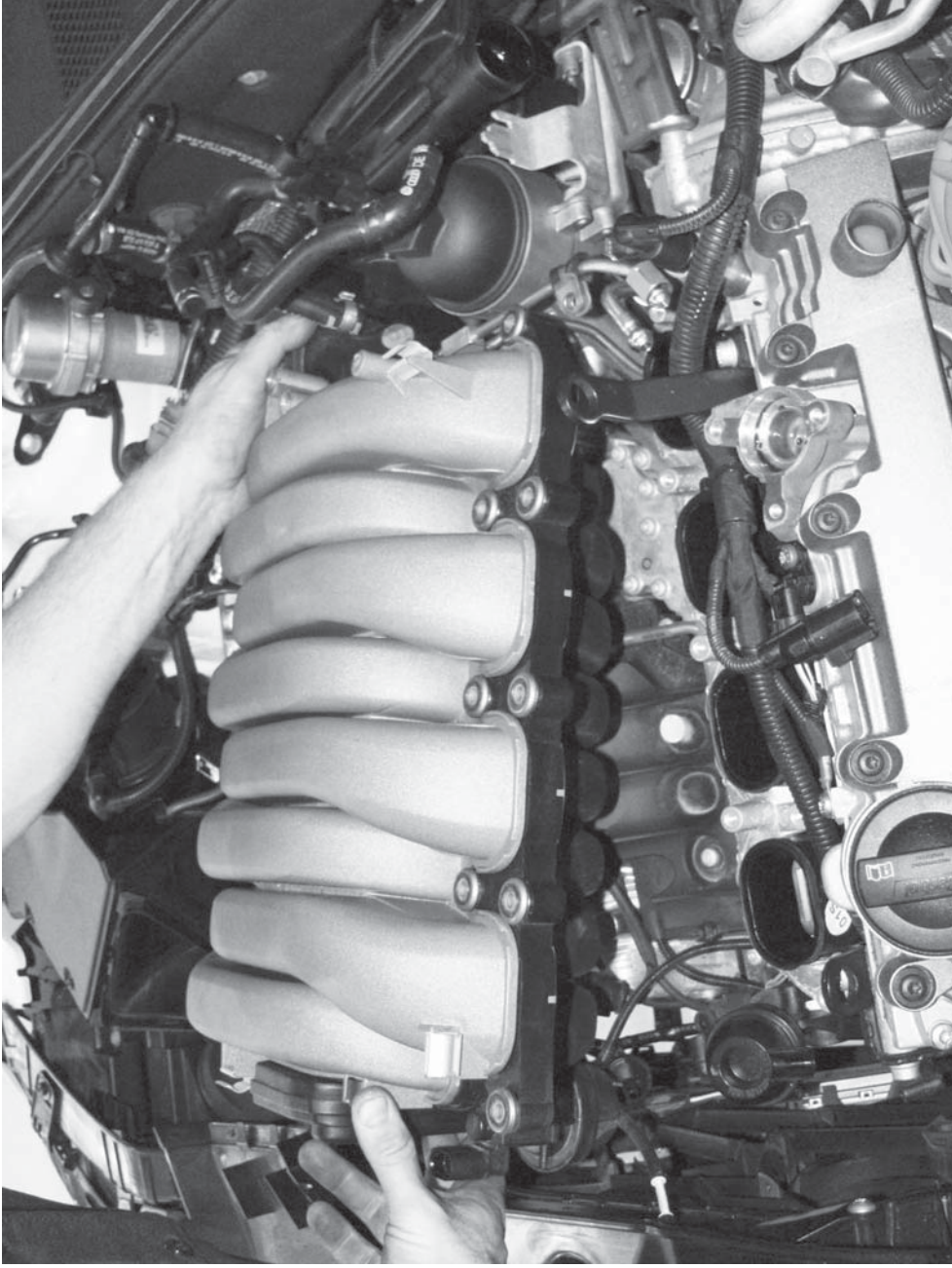

44) Lifting the right side of the manifold, remove the two large lines under the throttle body area.

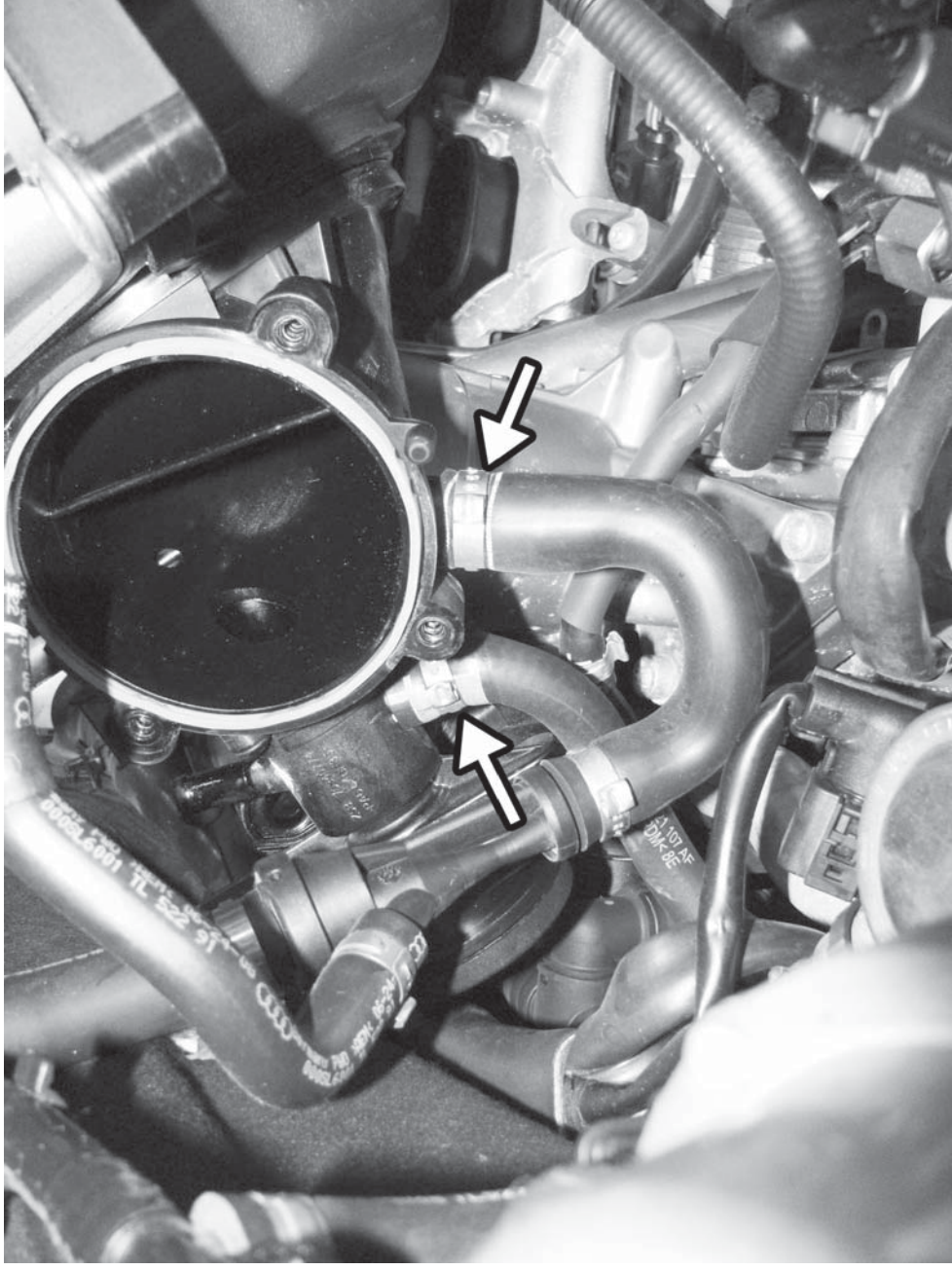

45) Lifting the left side of the manifold, remove the drain line from the oil separator. The intake manifold can now be removed from the car.

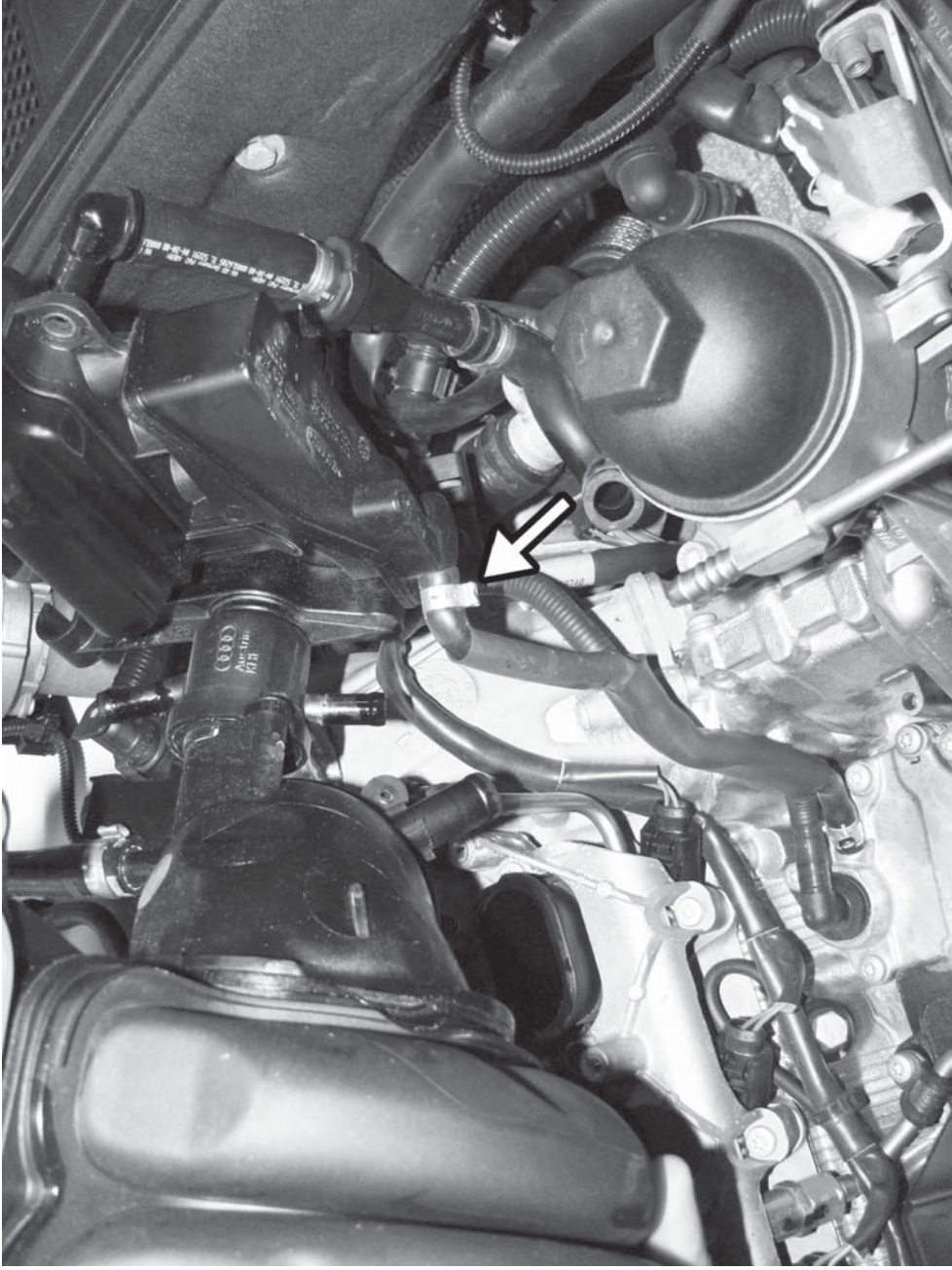

46) Disconnect eleven electrical connectors (eight injectors, G247, oil pressure switch, and vacuum solenoid). Cut the two cable ties holding the harnesses in place, and fold them back out of the way of the crankcase valley.

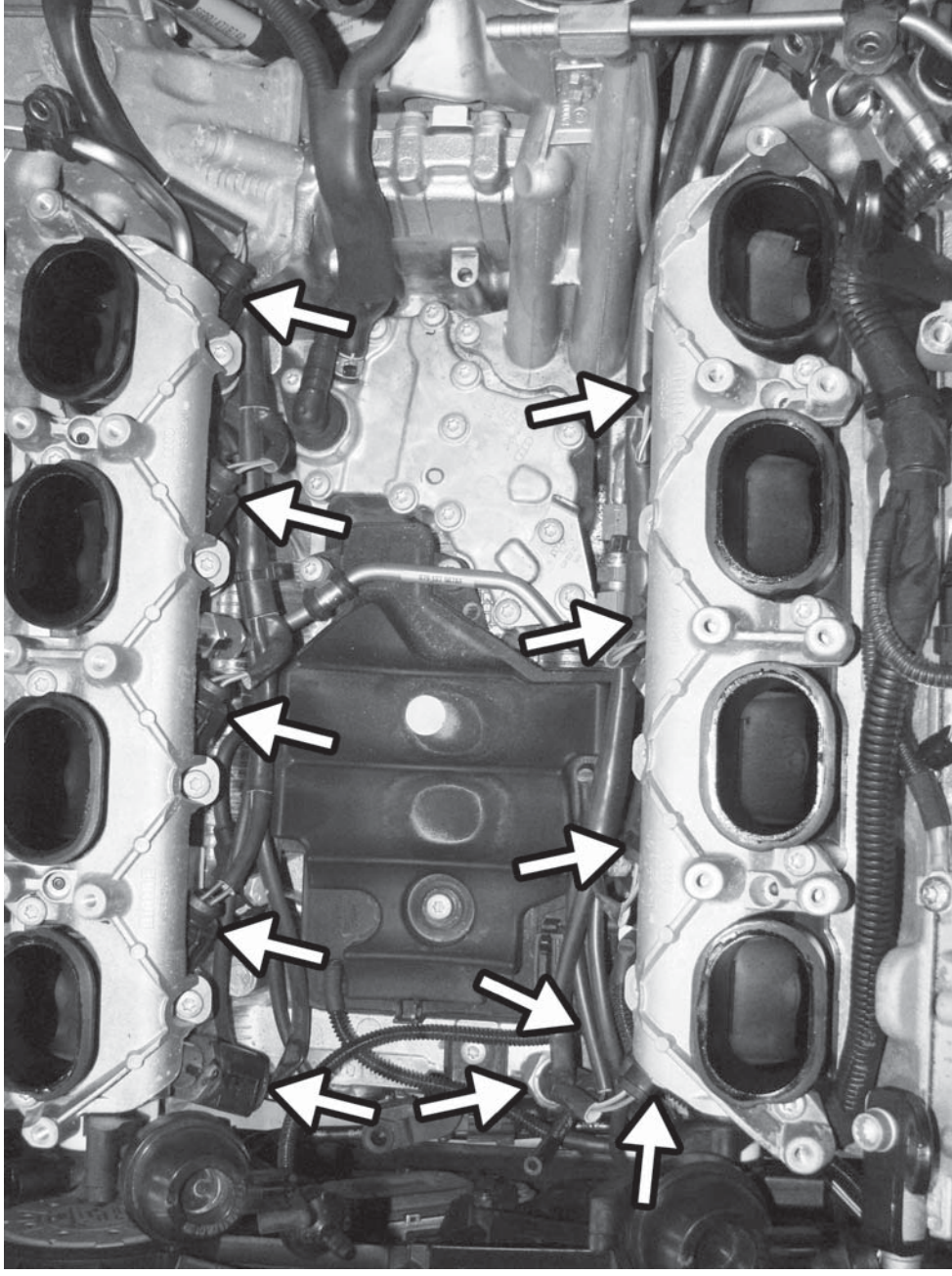

47) Remove the three T30 screws holding the metal fuel lines to the crankcase.

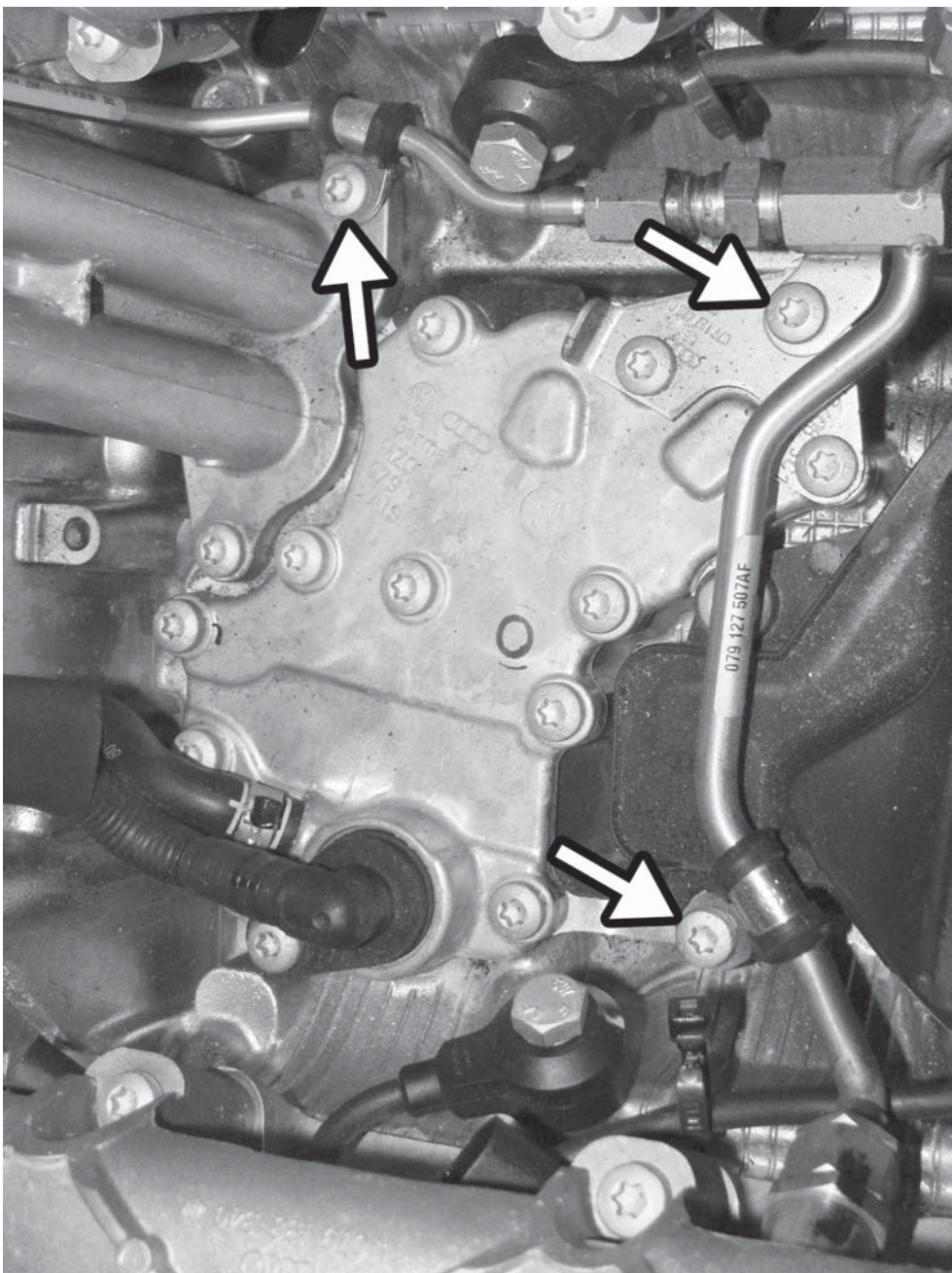

48) Remove the eighteen (nine on each side) T30 screws holding the runner flap assemblies to the cylinder heads.

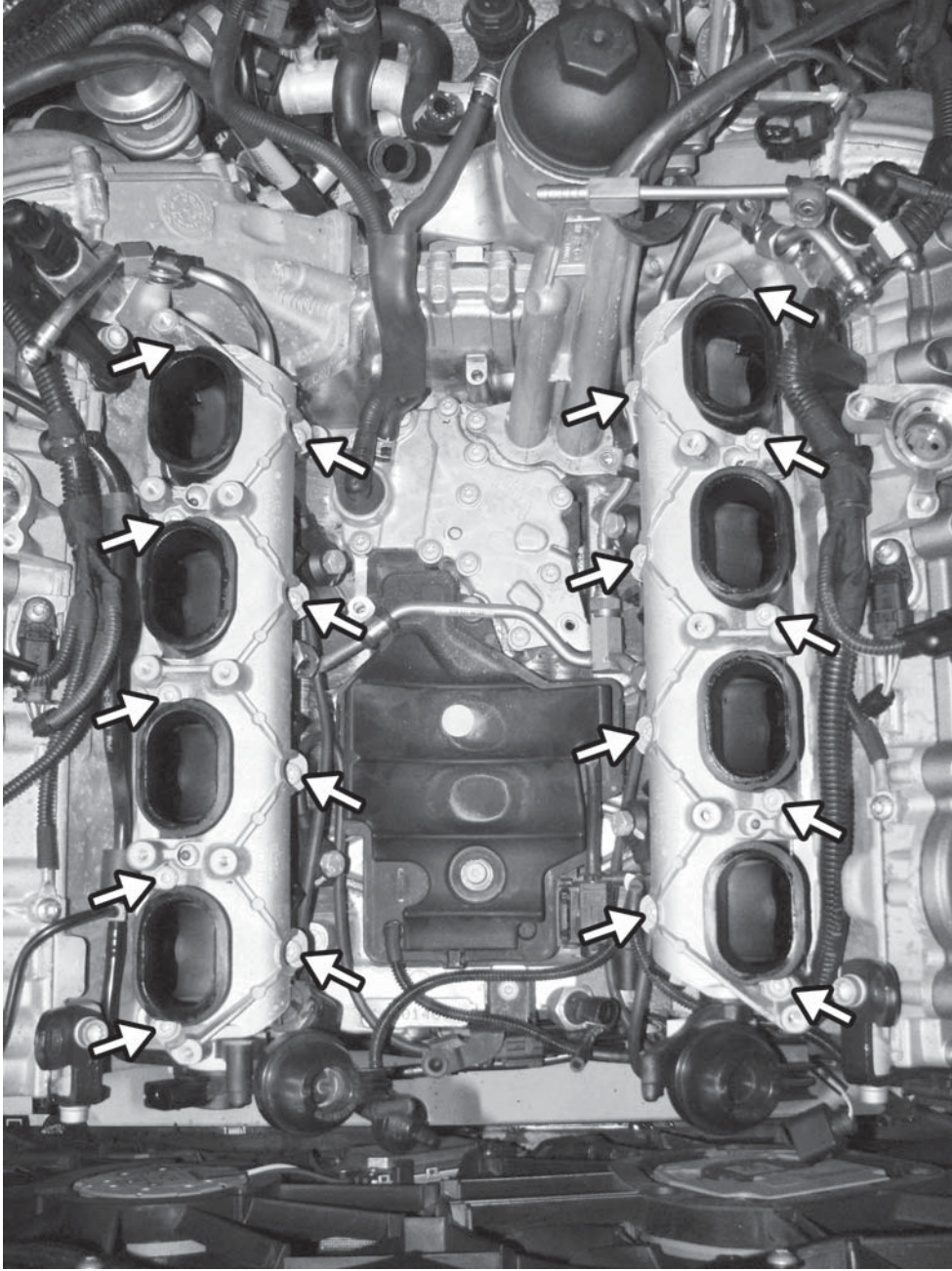

49) Carefully rock back and forth and then lift the runner flap/fuel line assembly from the engine.

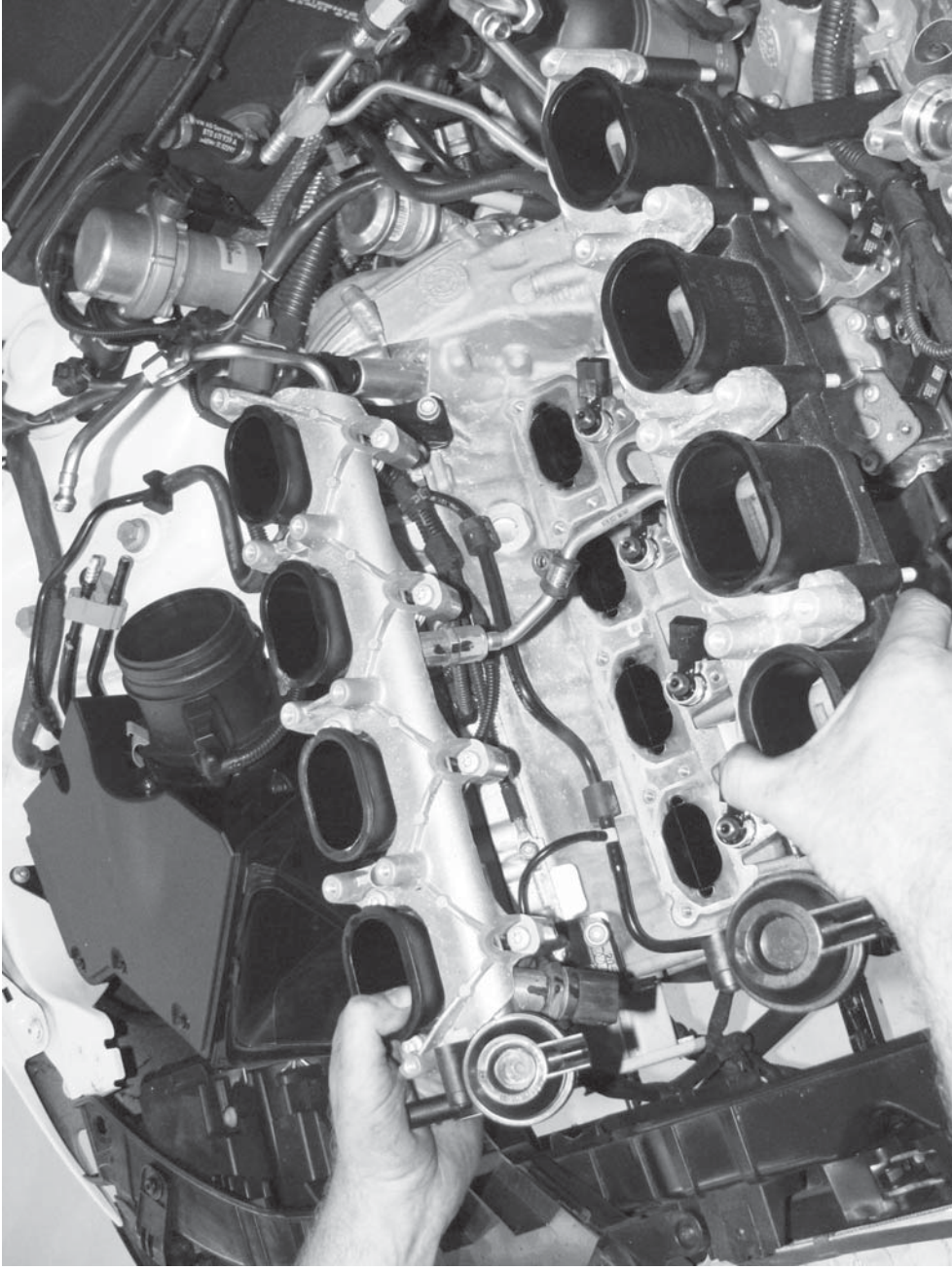

50) Cover the intake ports with a rag to prevent major engine damage by dropping something in the cylinder. Rags may need to be removed for some assembly items, but generally the ports should stay covered.

Remove and/or account for the eight O-rings that were on the fuel injectors. Some may still be inside the intake runner assembly. Once the old O-rings are located, discard and replace them with the supplied O-rings.

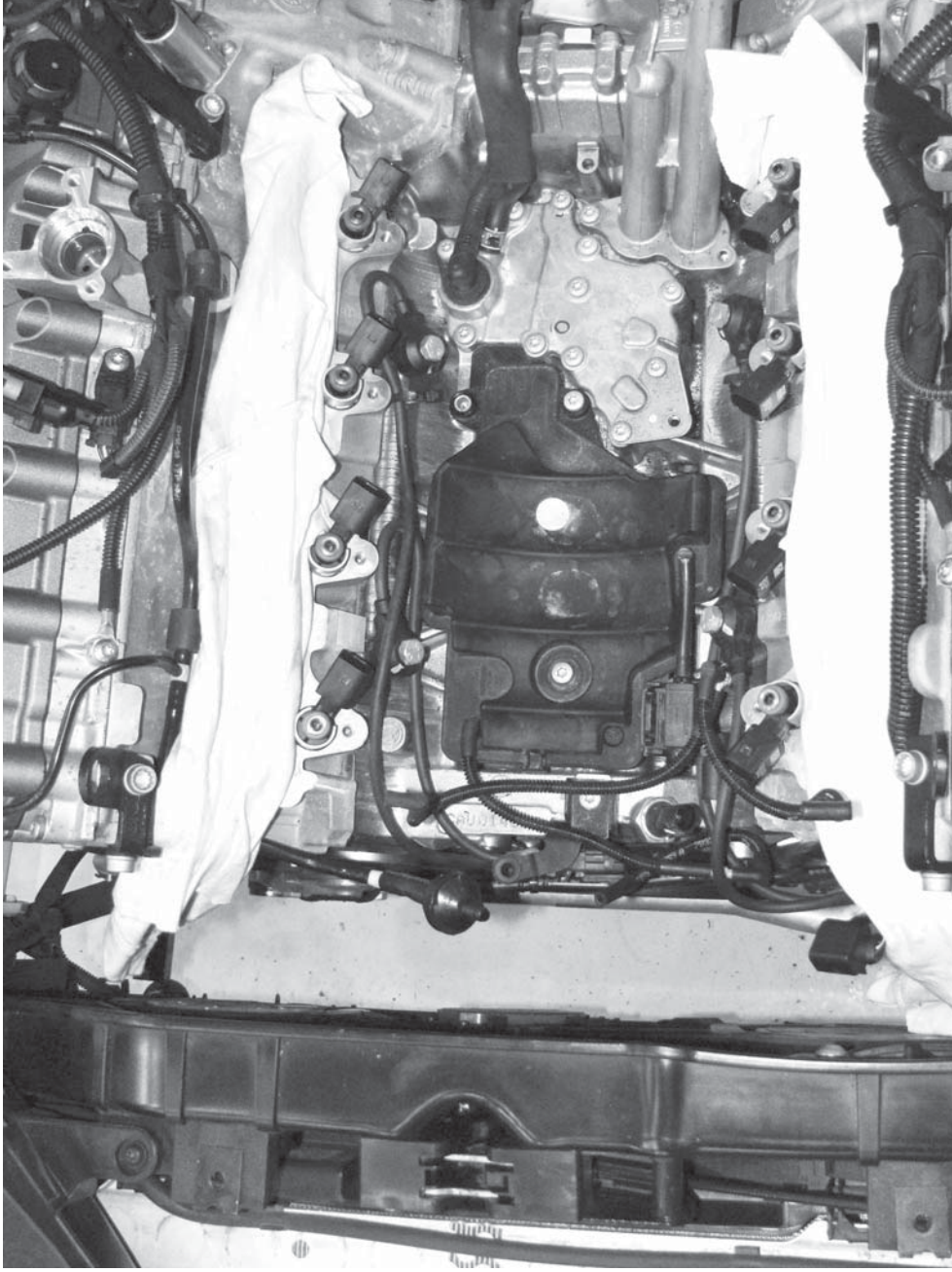

51) Remove the two T30 screws and remove the vacuum reservoir and all vacuum lines.

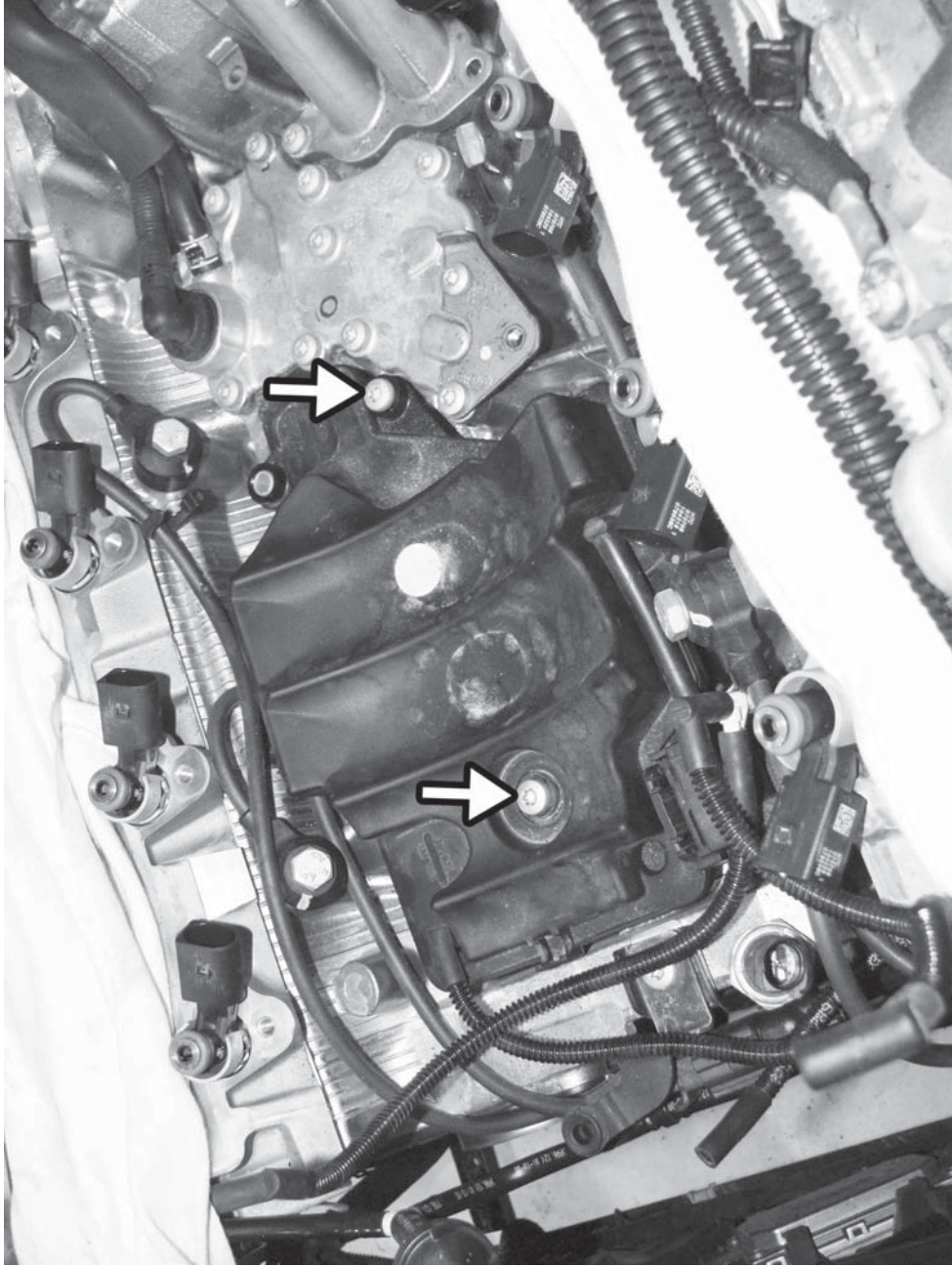

52) After removing the shipping plugs and lubricating the injector O-rings, carefully install the right fuel rail assembly.

Install the two T30, M6x18mm screws to hold the fuel rails down, and torque to 9Nm.

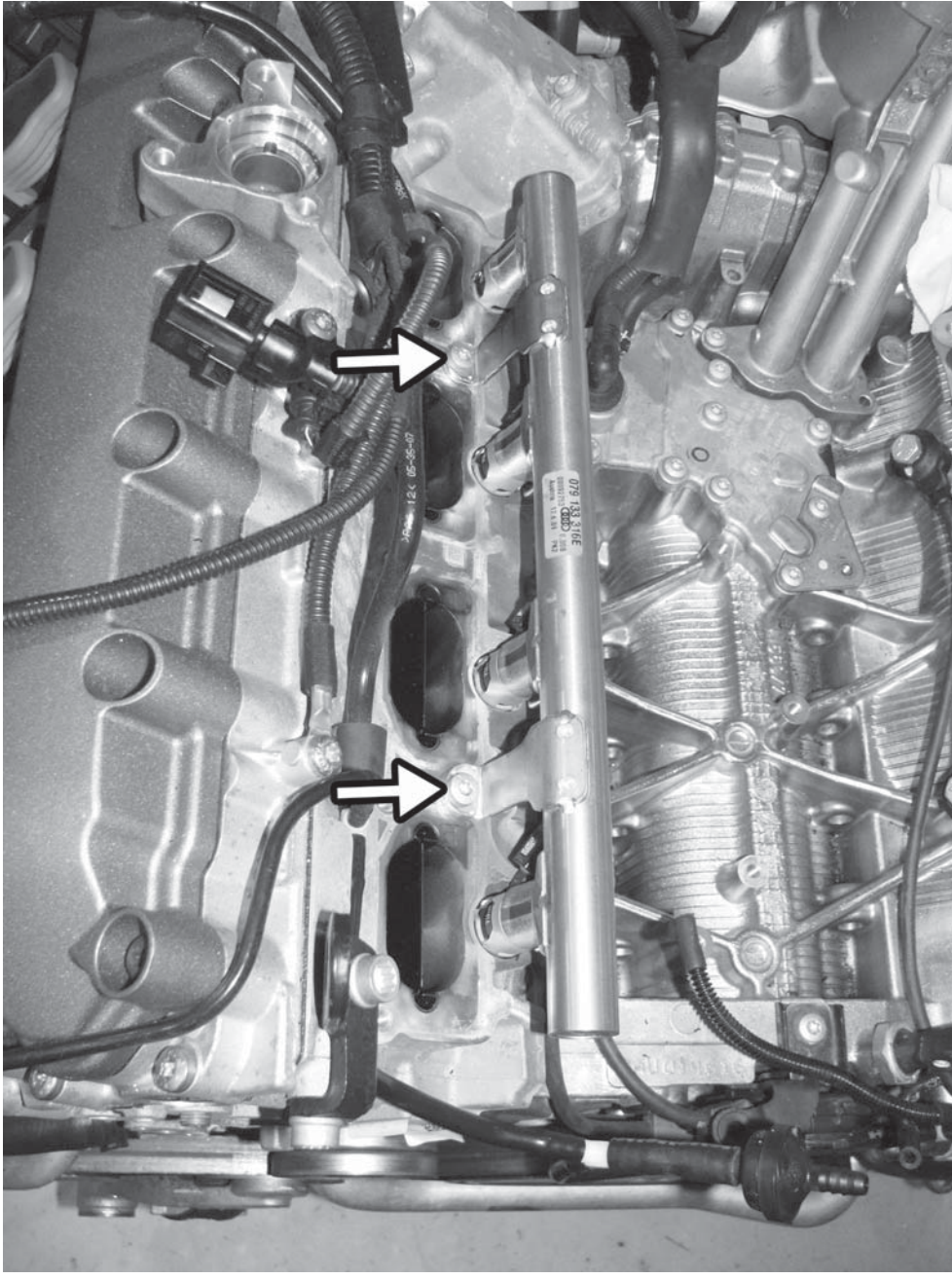

53) Install the four T30 M6x40 screws in the fuel rail and torque to 9Nm.

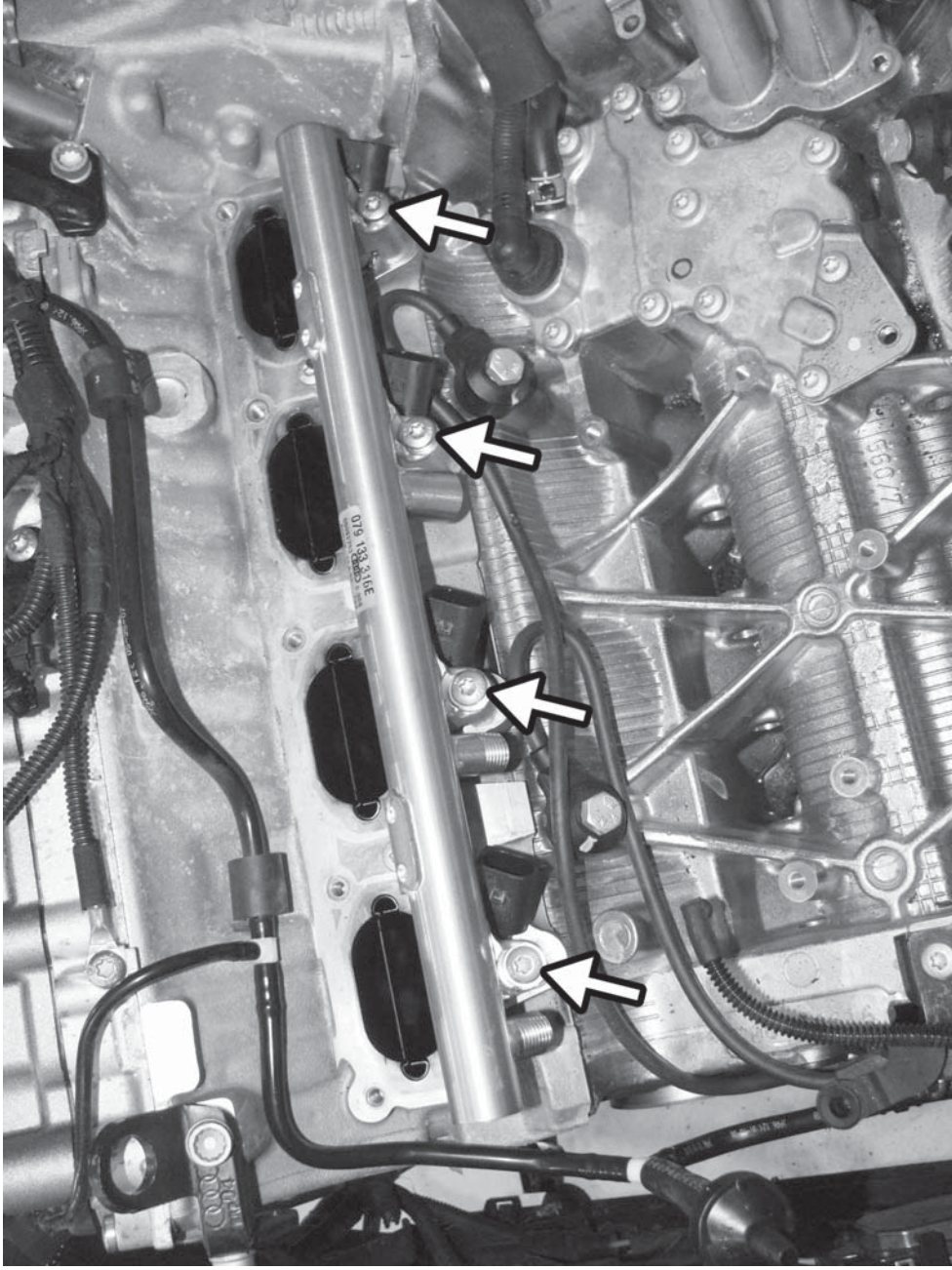

54) Install the brass fuel pressure bypass valve in the fuel rail and tighten with a 17mm wrench.

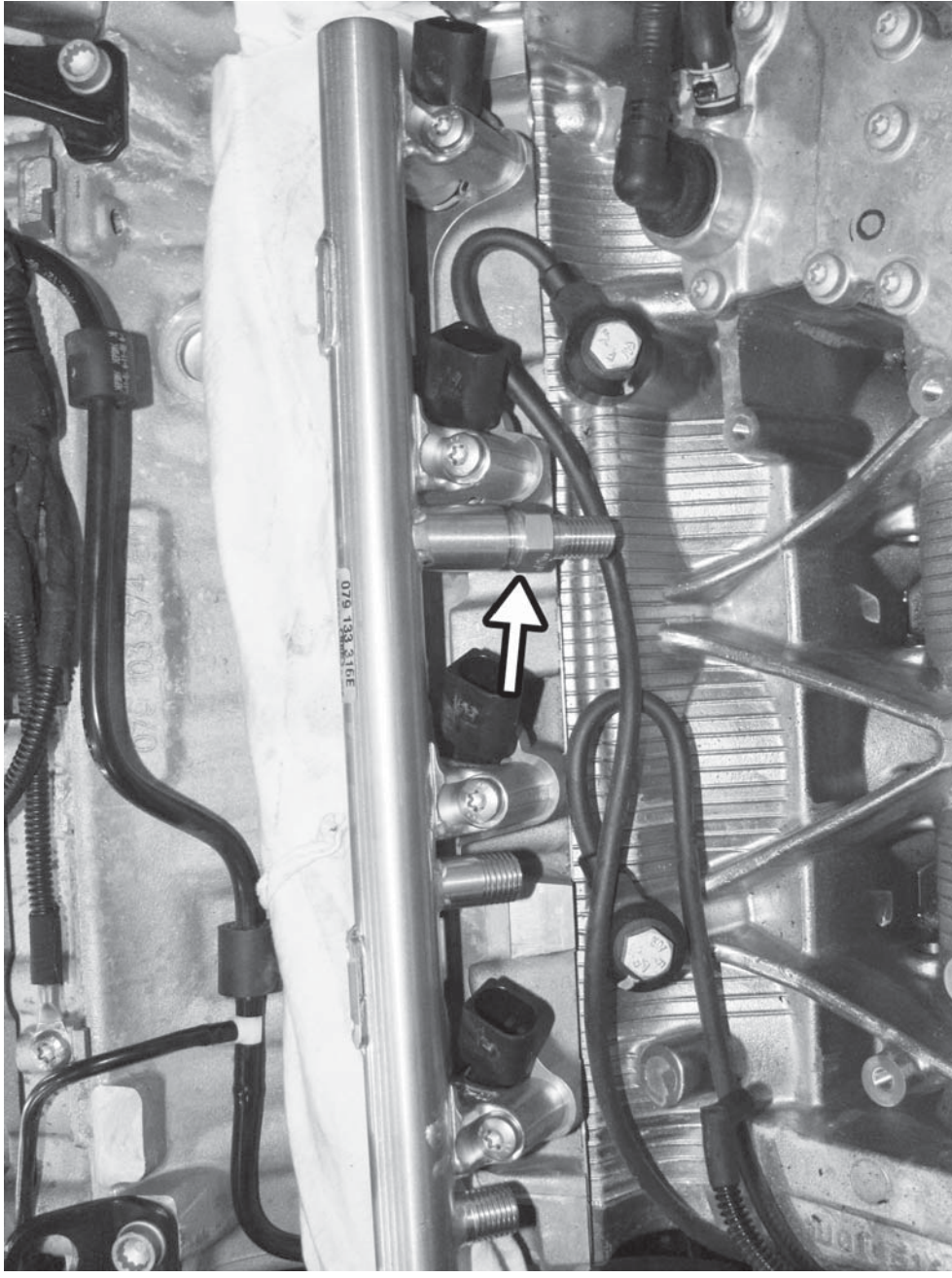

55) After removing the shipping plugs and lubricating the injector O-rings, carefully install the left fuel rail assembly.

Install the two T30, M6x18mm screws to hold the fuel rails down, and torque to 9Nm.

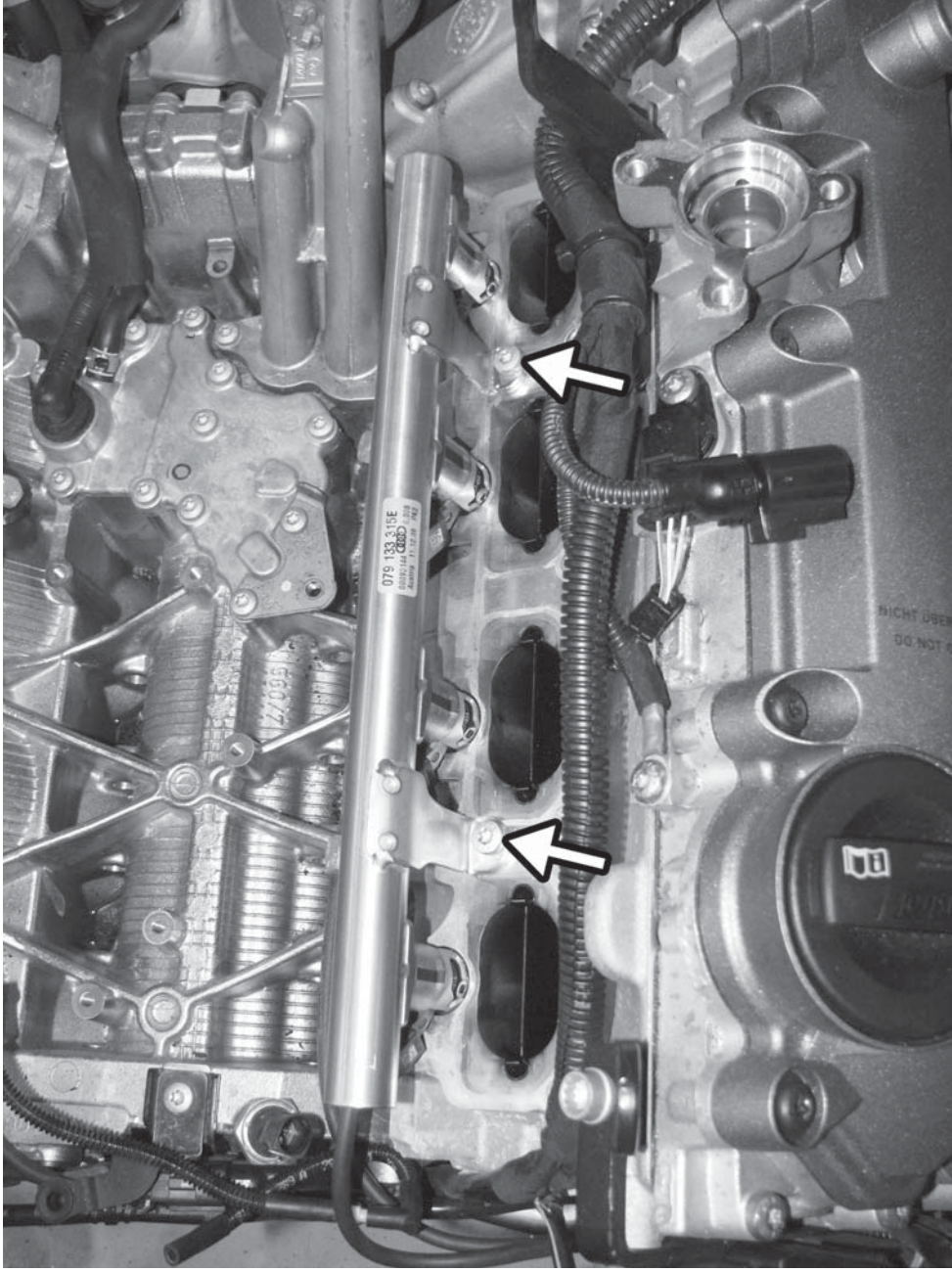

56) Install the four T30 M6x40 screws in the fuel rail and torque to 9Nm.

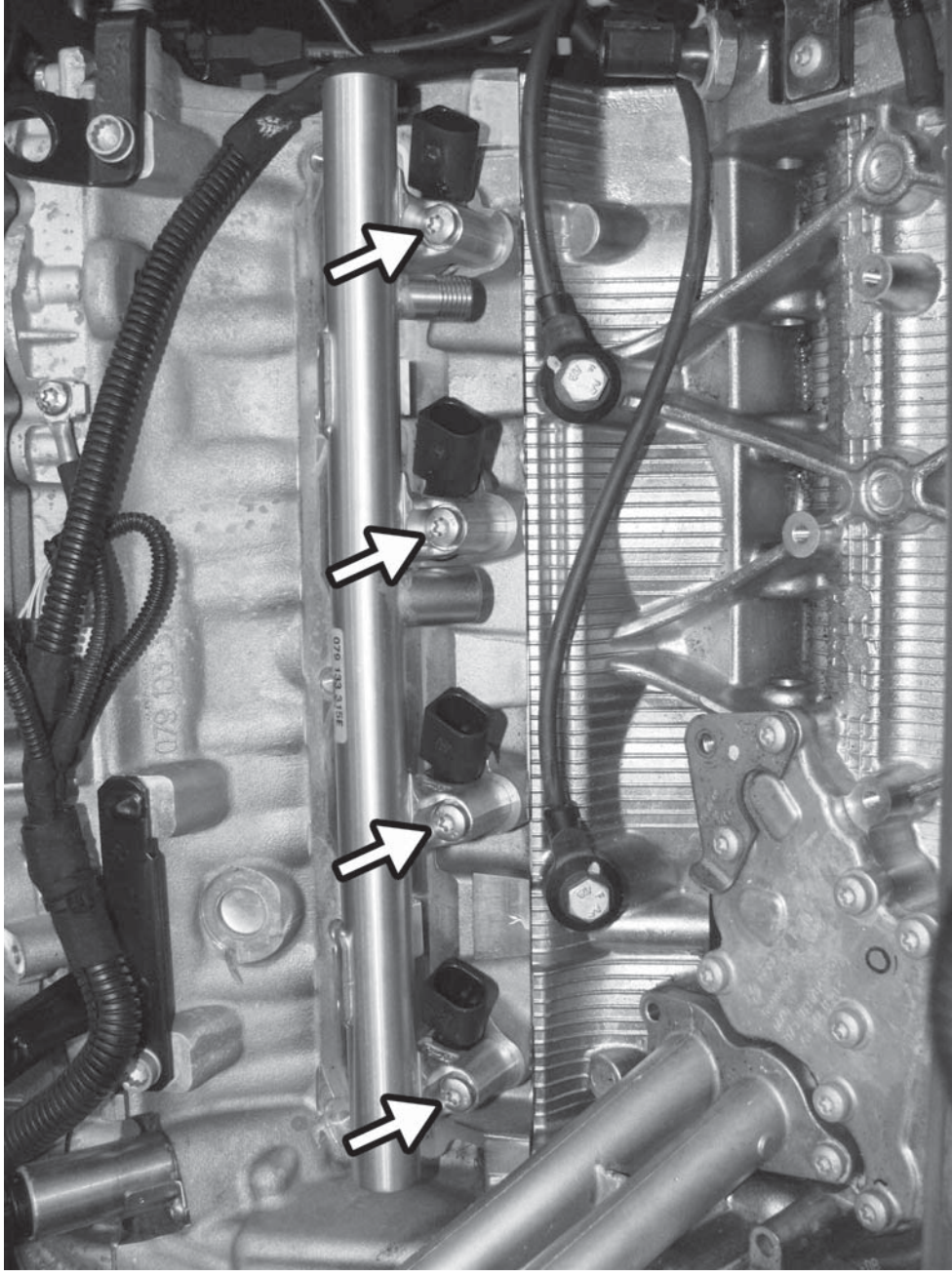

57) Install the brass fuel pressure bypass valve in the fuel rail and tighten with a 17mm wrench.

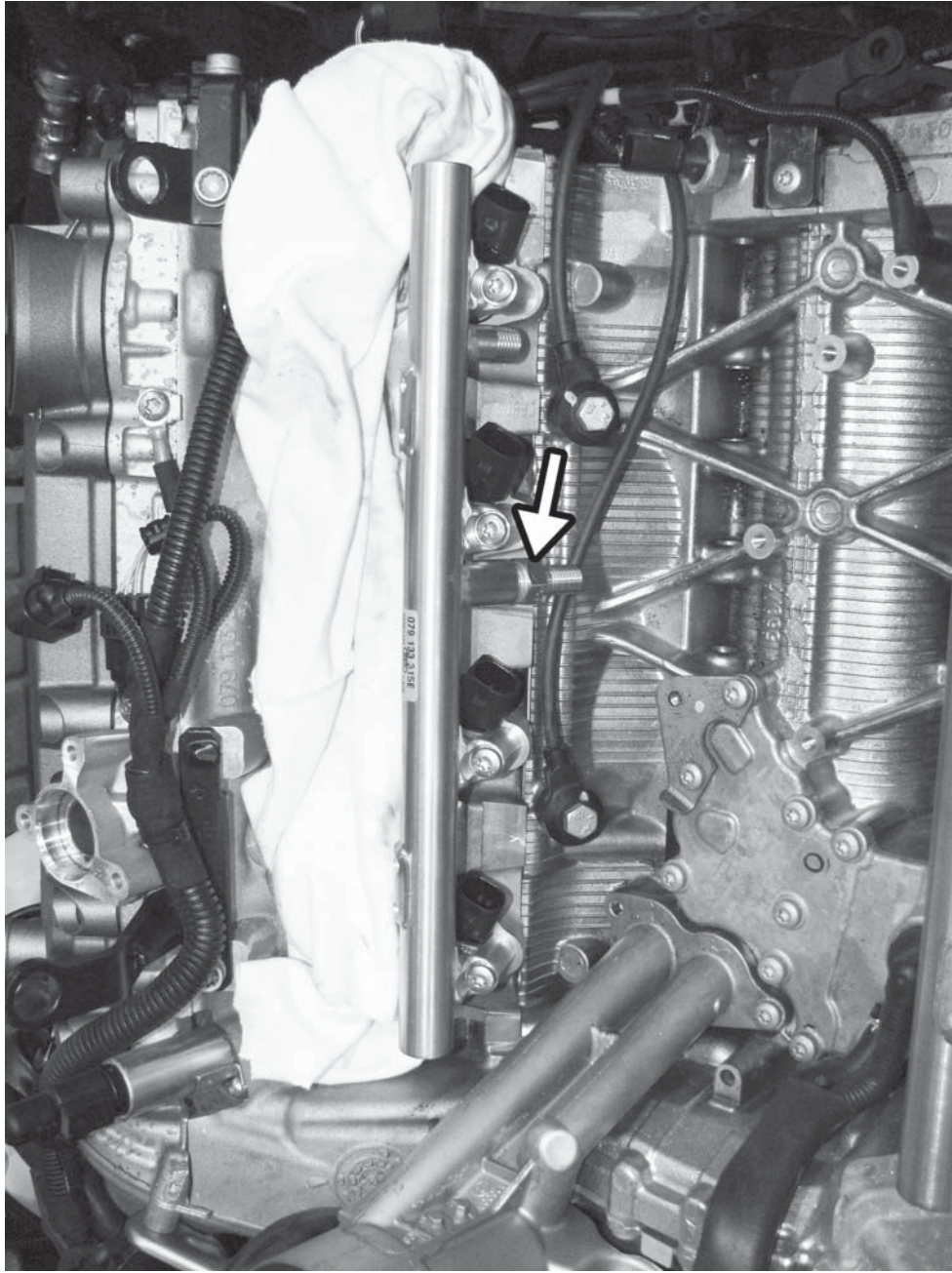

58) With a 24mm wrench, remove the G247 sensor from the original fuel rail assembly.

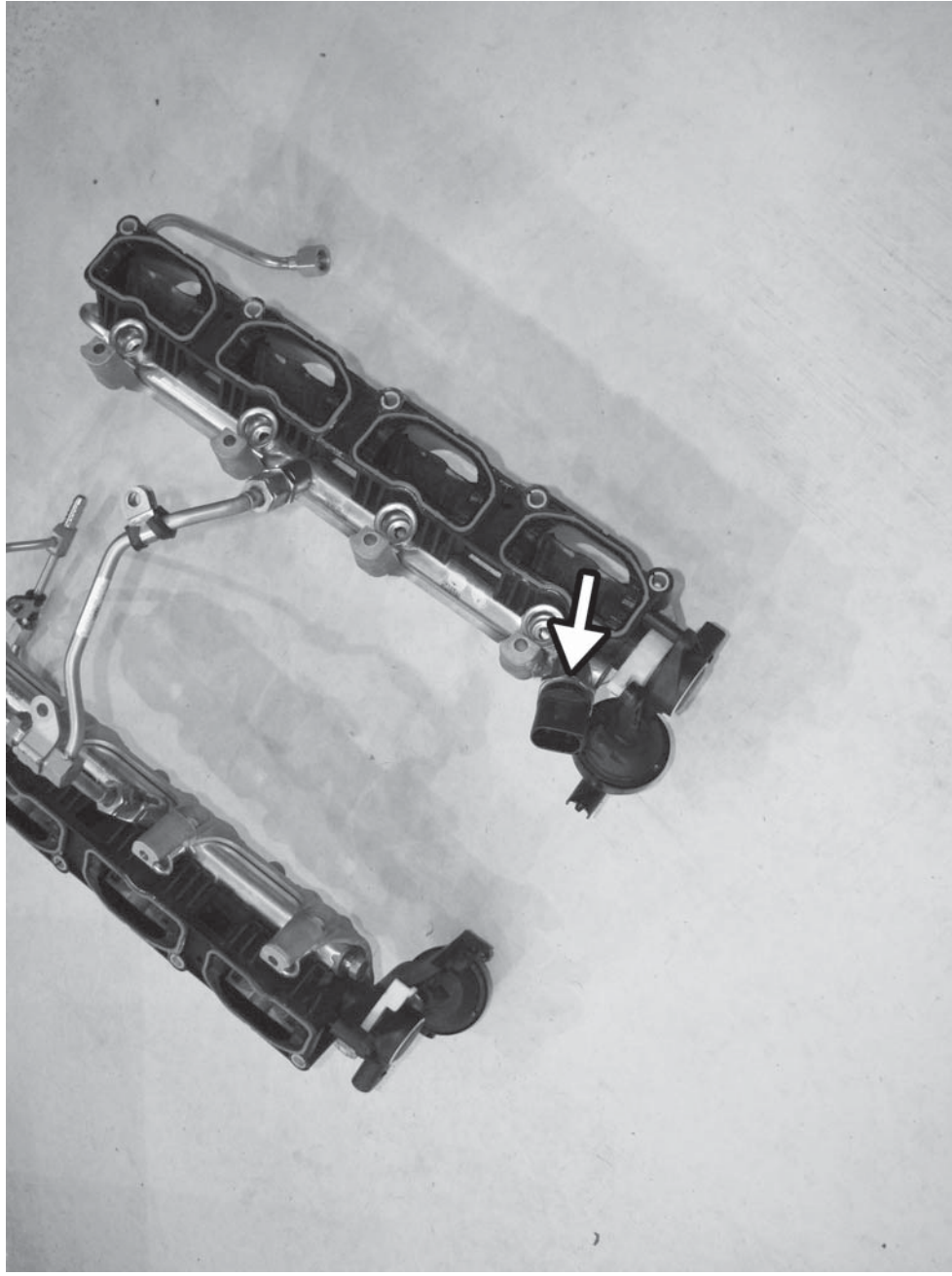

59) Install the G247 sensor into the new, supplied fuel rail, along with one of the fuel plugs and crush washers as shown.

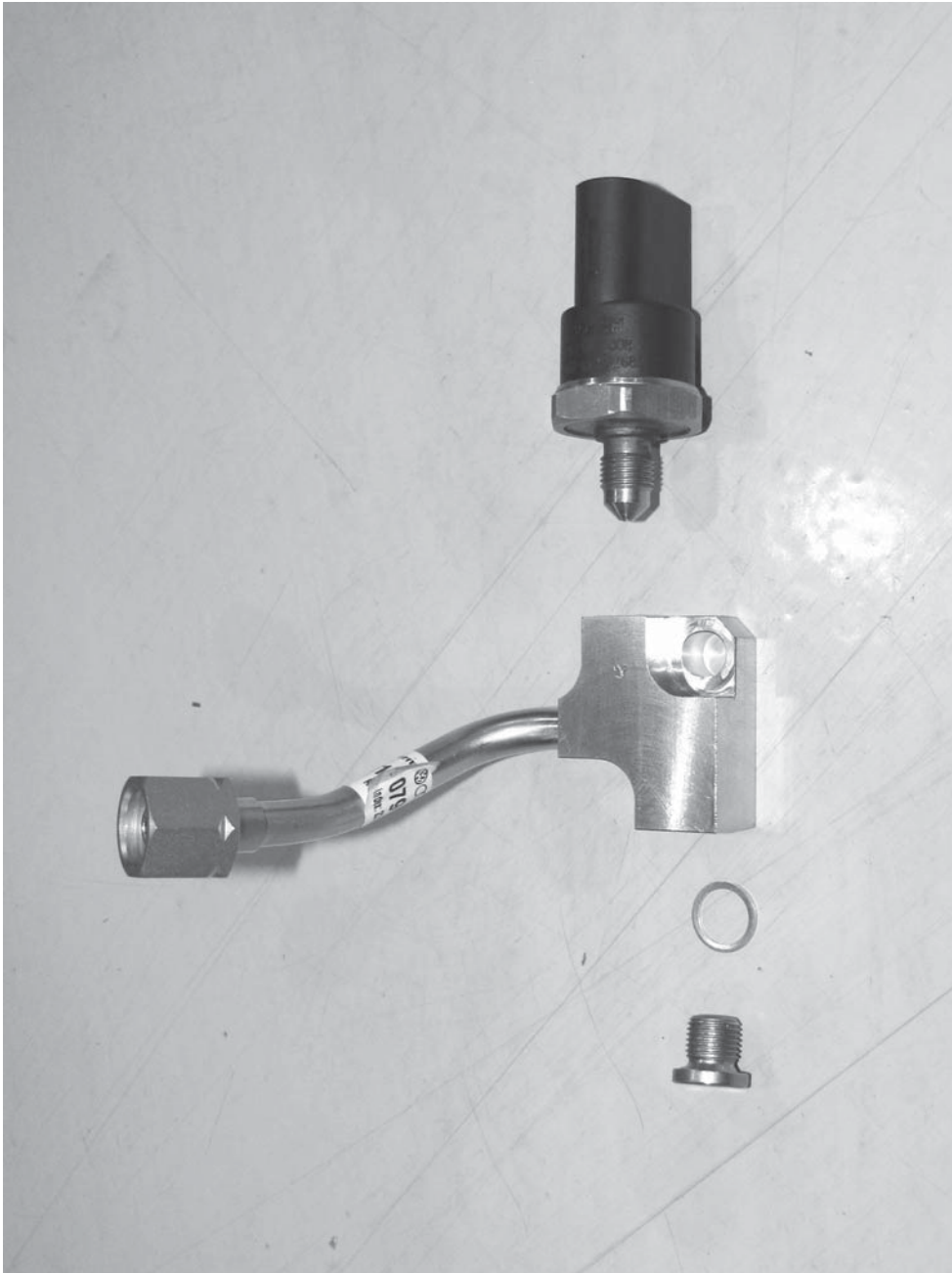

60) Install the assembled small fuel rail onto the right fuel rail on the engine and tighten the line. Secure the line with the supplied T30 M6x18 bolt and torque to 9Nm. Make sure all connections are tight.

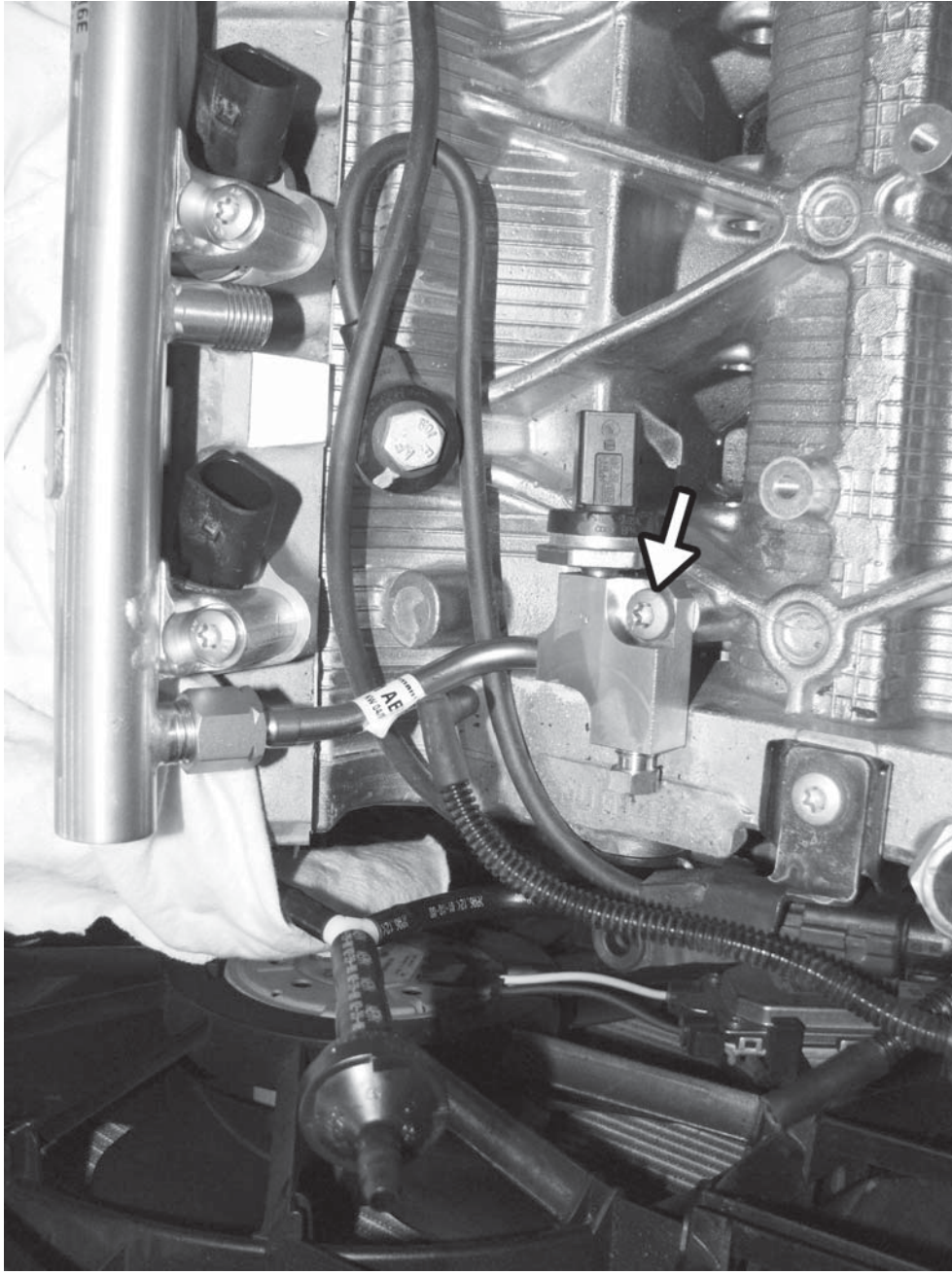

61) Install the smaller, supplied 14mm diameter fuel line. Be sure to route the metal line behind the two vacuum lines at the back of the crankcase valley. Connect each side of the lines to the two fuel pressure bypass valves and tighten the lines.

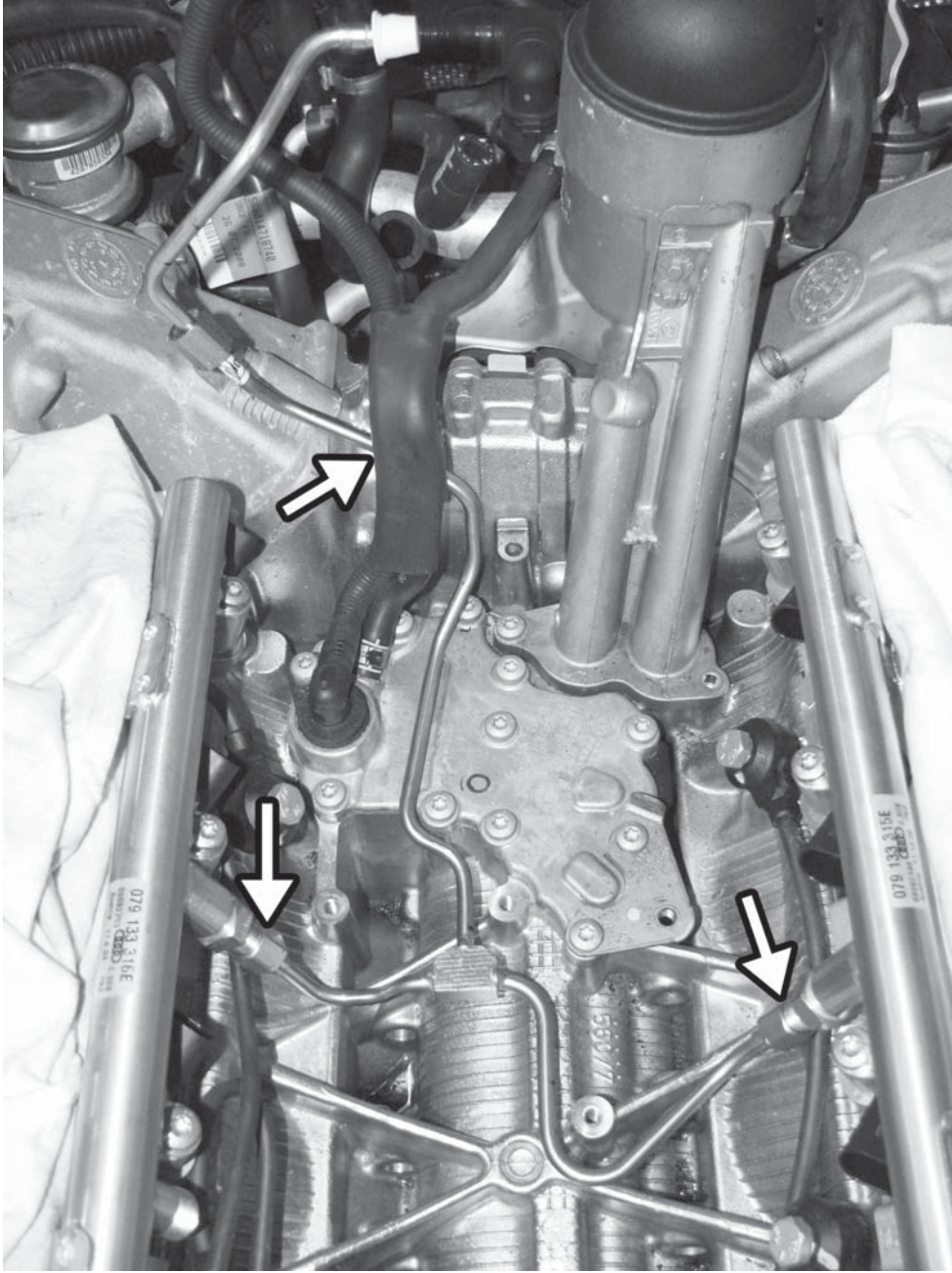

62) Attach one of the smaller rubber line brackets to the 14mm fuel line with a supplied T30 M6x16 screw and torque to 9Nm.

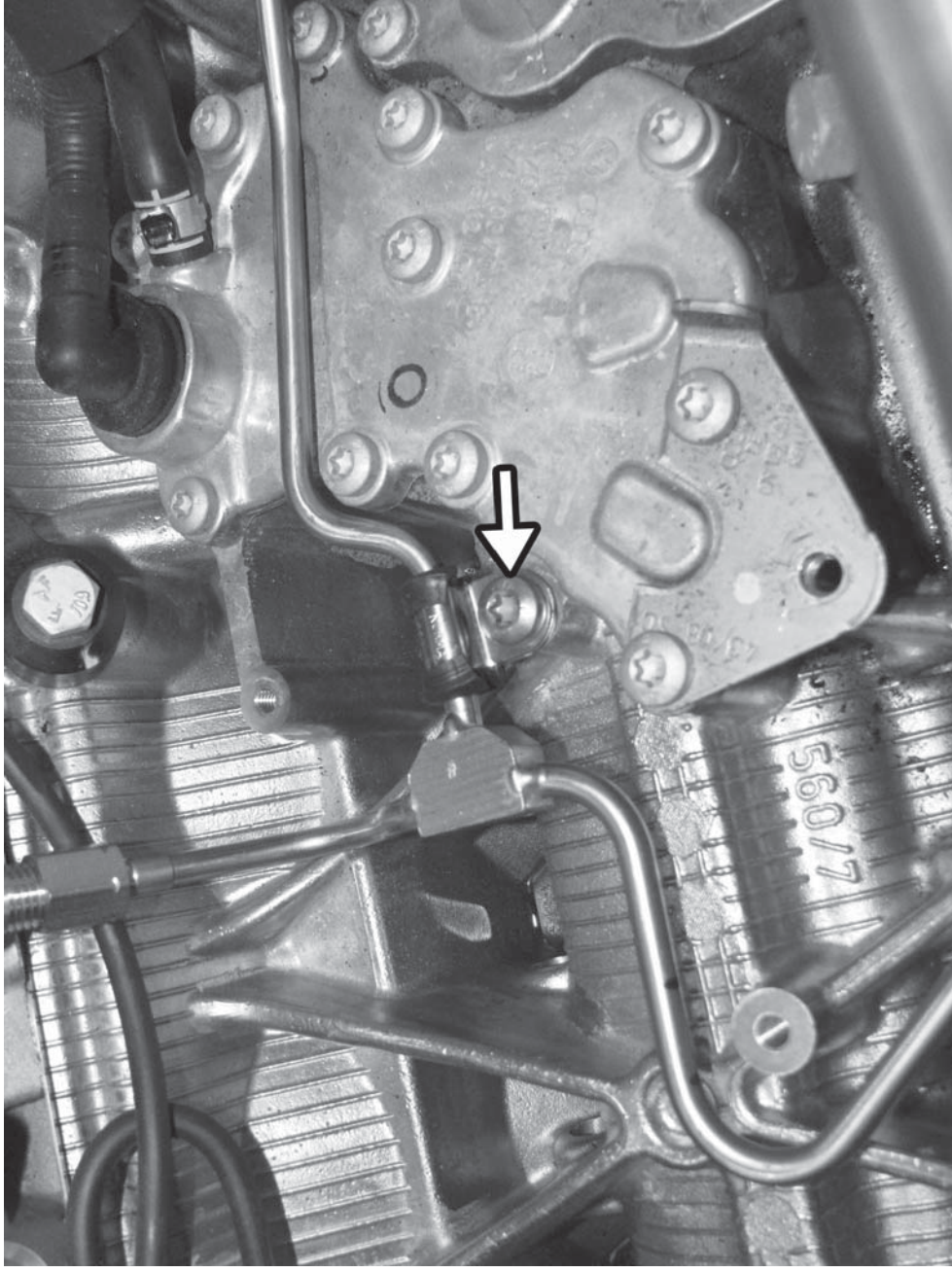

63) Install the larger, supplied 17mm diameter fuel line. As with the 14mm line, be sure to route the metal line behind the two vacuum lines at the back of the crankcase valley. Connect each side of the lines to the two ports directly on the fuel rails and tighten the lines.

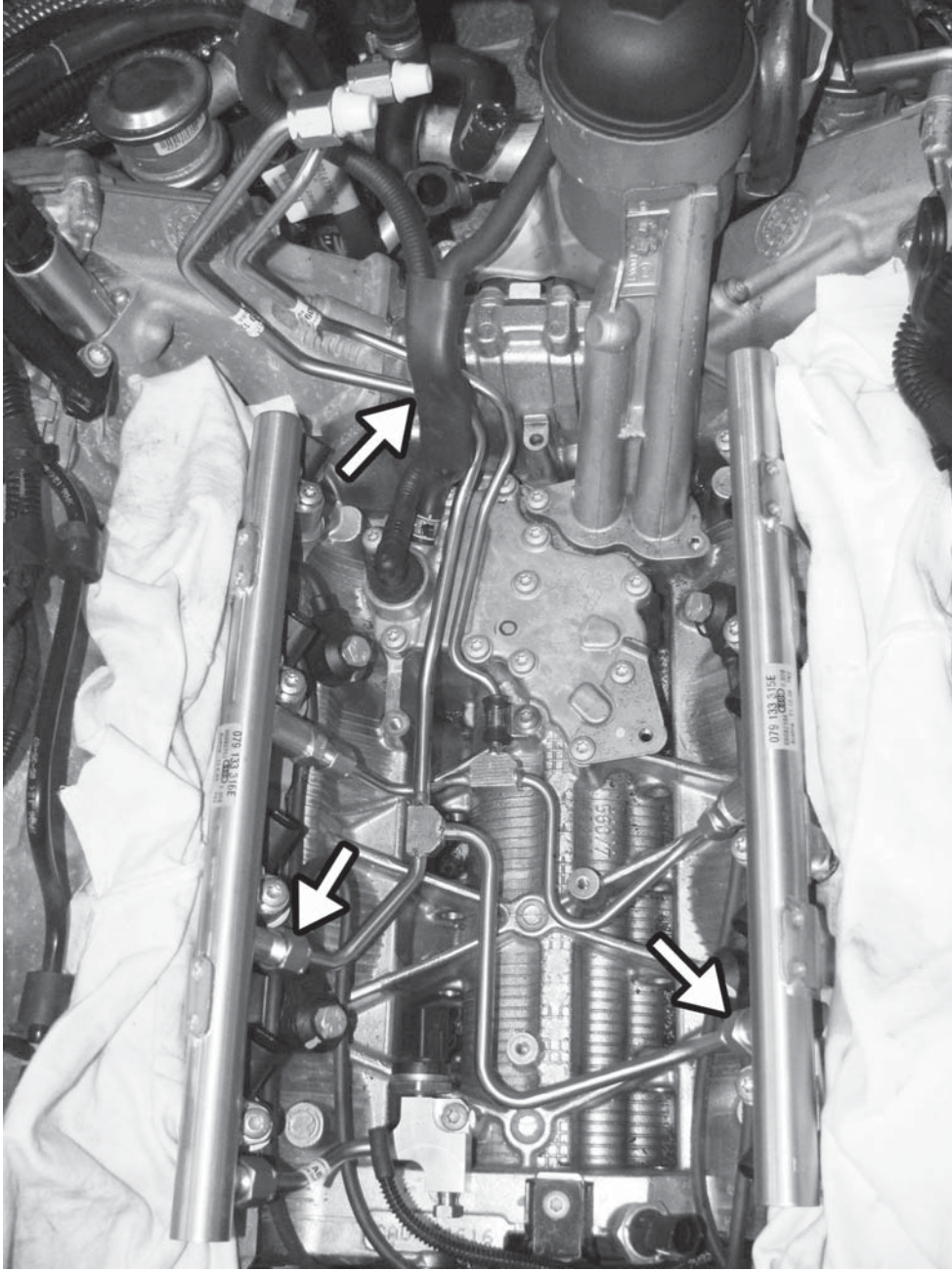

64) Attach one of the larger rubber line brackets to the 17mm fuel line with a supplied T30 M6x16 screw and torque to 9Nm.

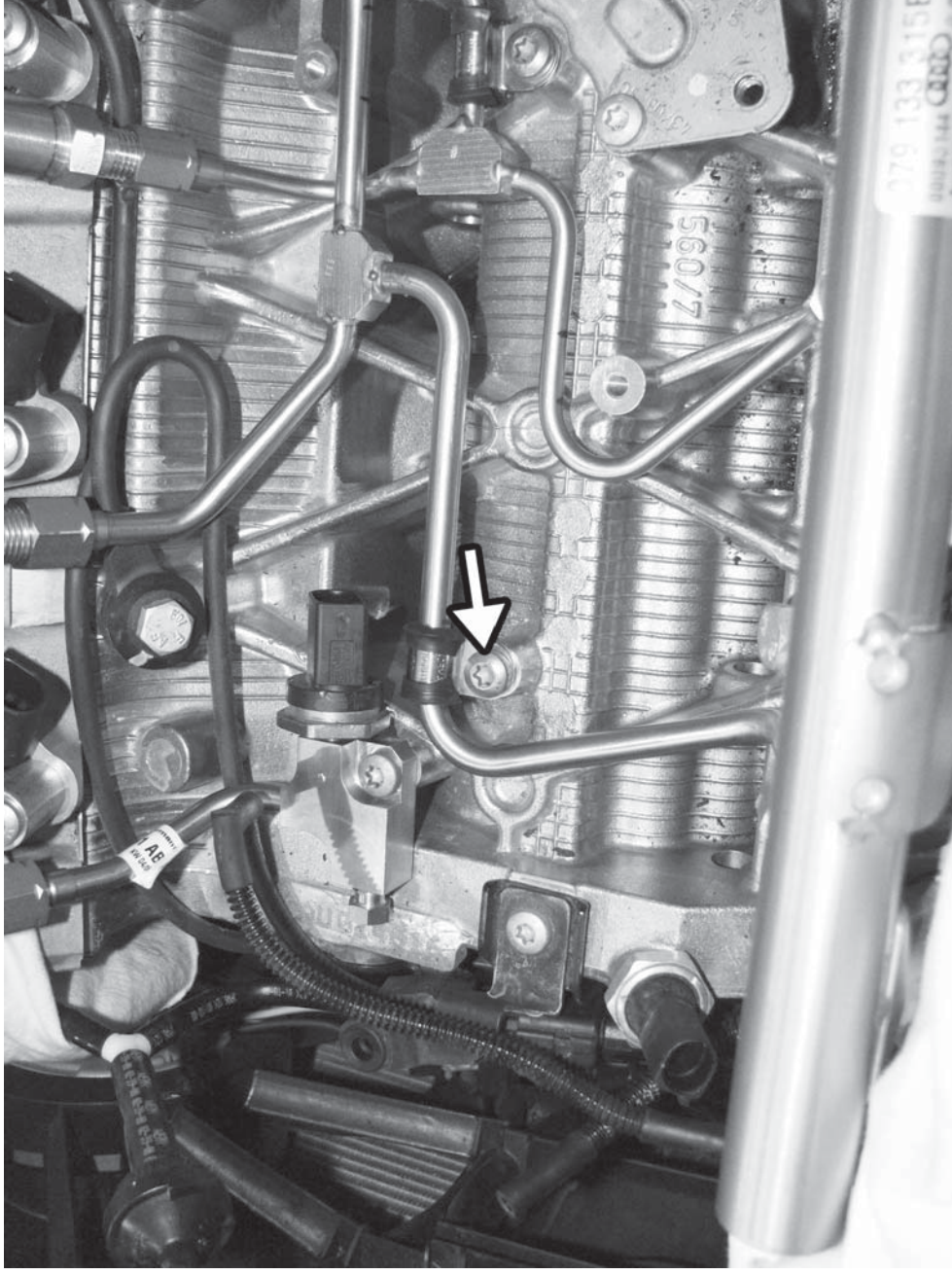

65) Reinstall the wiring harness down the right cylinder head, connecting five connectors (four injectors, one G247).

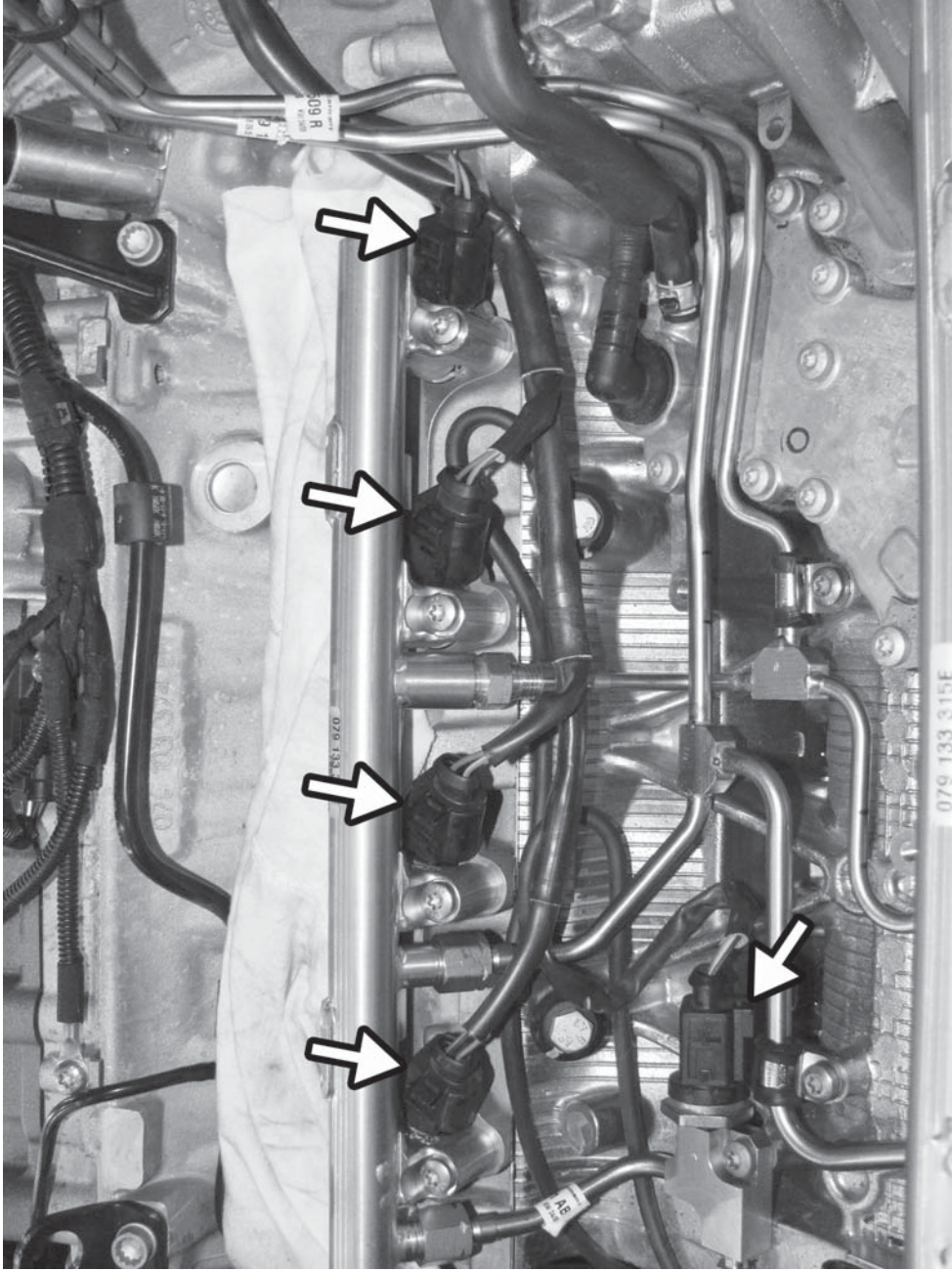

66) Reinstall the wiring harness down the left cylinder head, connecting the five connectors (four injectors, one oil pressure sensor). The two pin connectors for the vacuum solenoid is not connected.

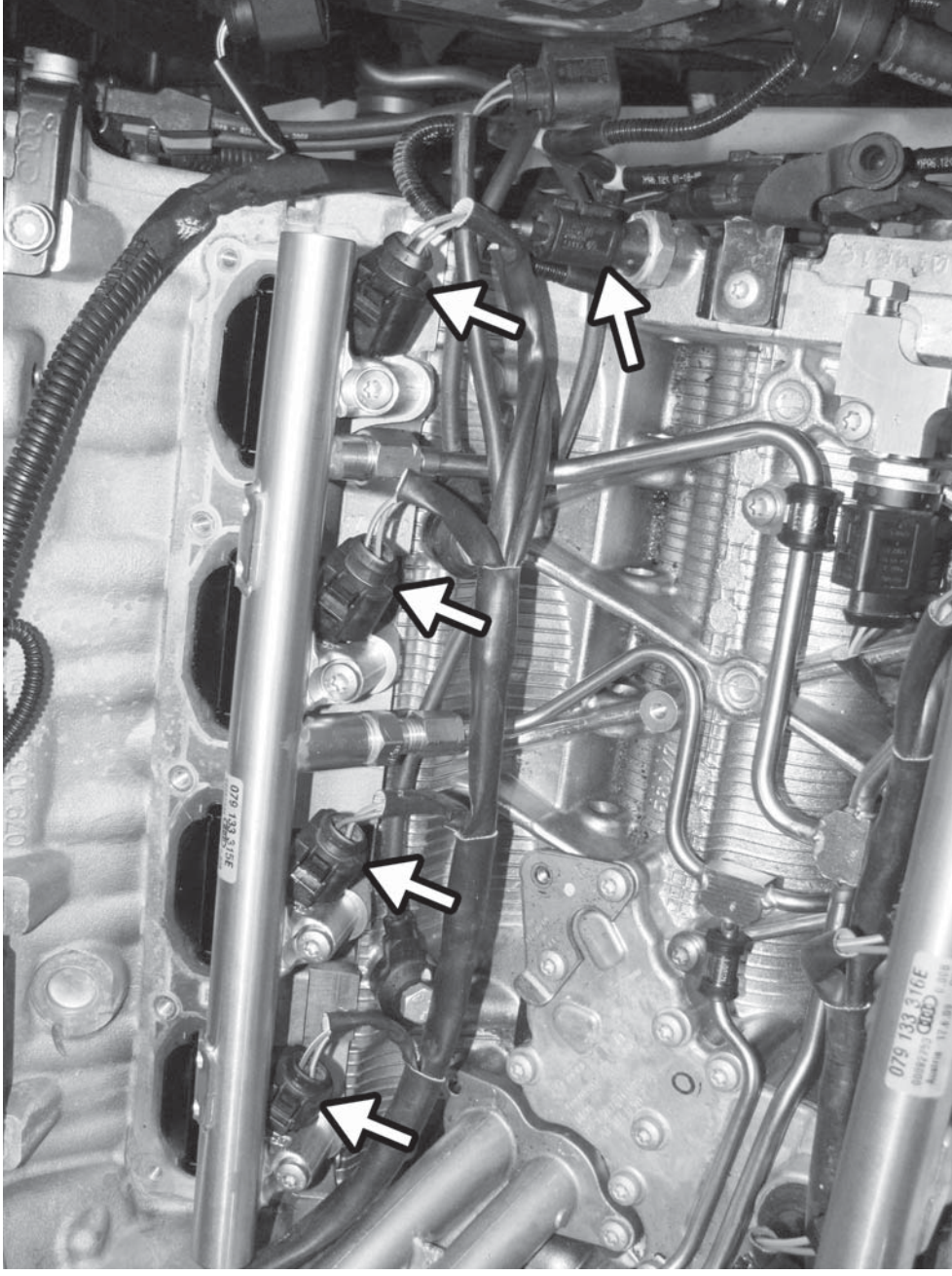

67) Install the two remaining rubber line brackets (one larger and one smaller) on their respective fuel lines, attaching each with a T30 M6x16 screw and torquing to 9Nm.

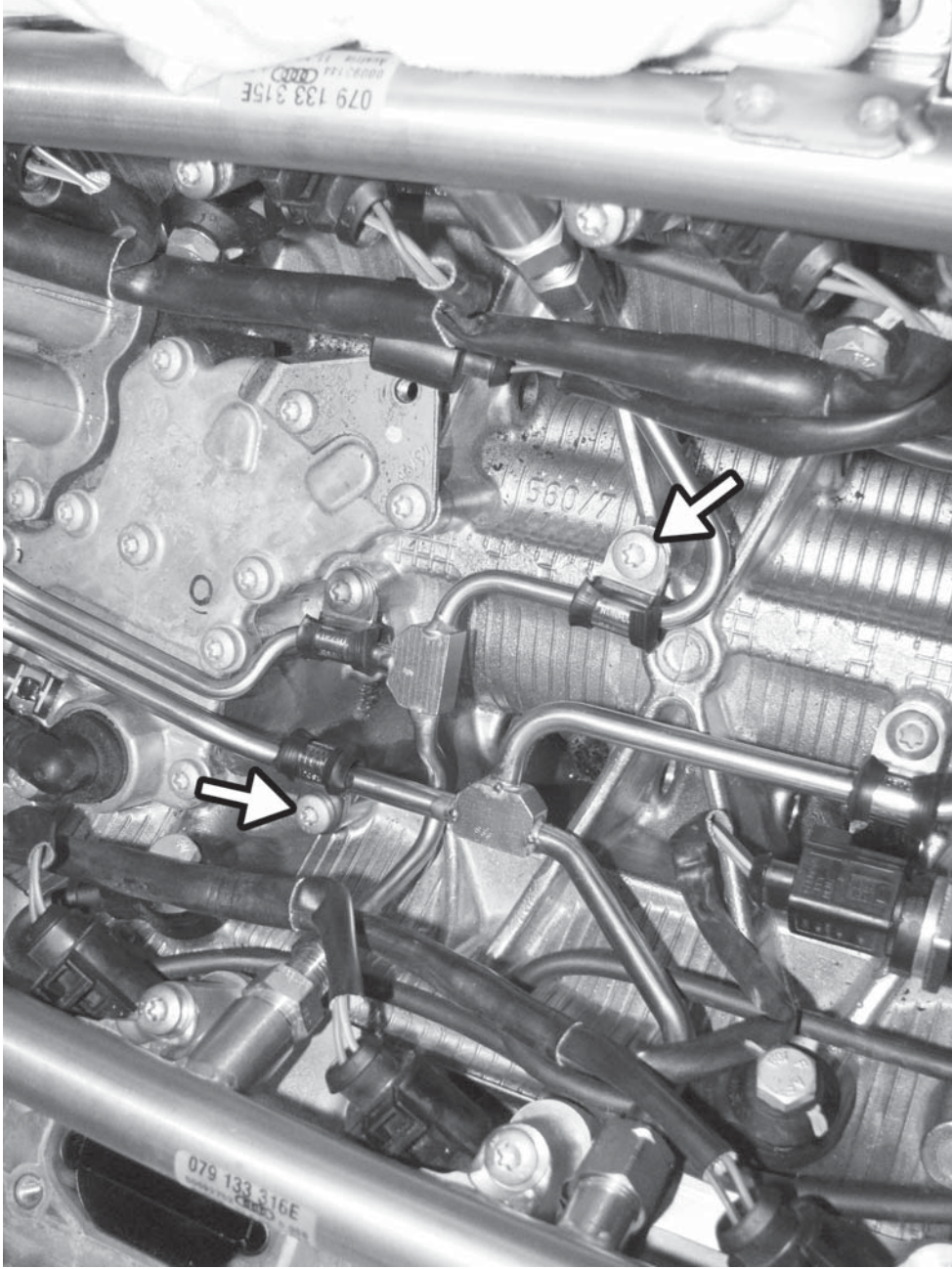

68) Install a cable tie to hold the two upper fuel line connectors in place. If these drop down the lines before they are connected, the supercharger assembly will have to be removed to retrieve them.

Check all fuel line connections to ensure they are tight. A small leak can cause a fire, and will also require the supercharger to be removed to tighten.

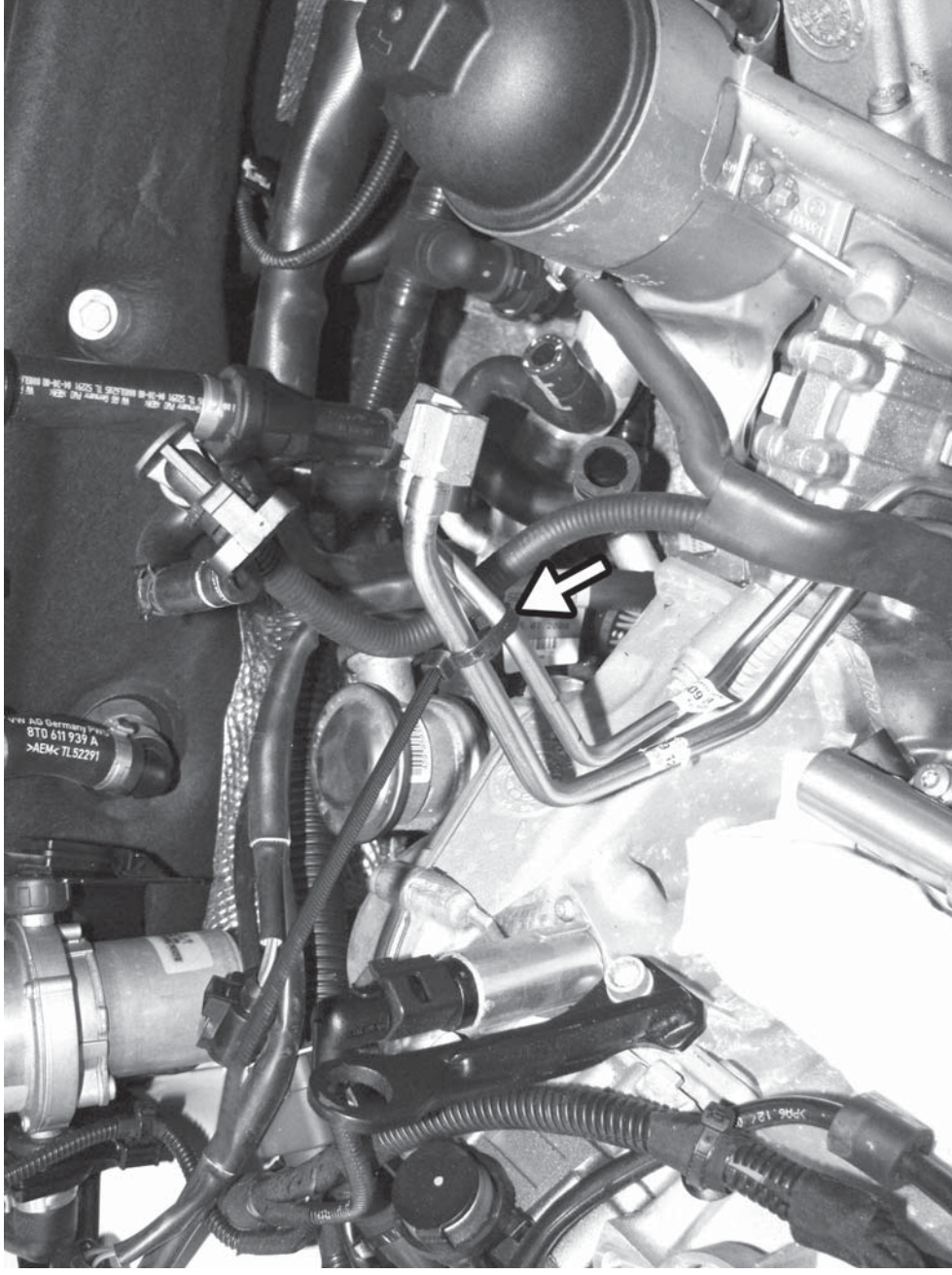

69) Disconnect the rubber vacuum line from the airbox where it meets the hard plastic line in front of the right cylinder head. Also disconnect the rubber vacuum line to the hard pipe on the right shock tower.

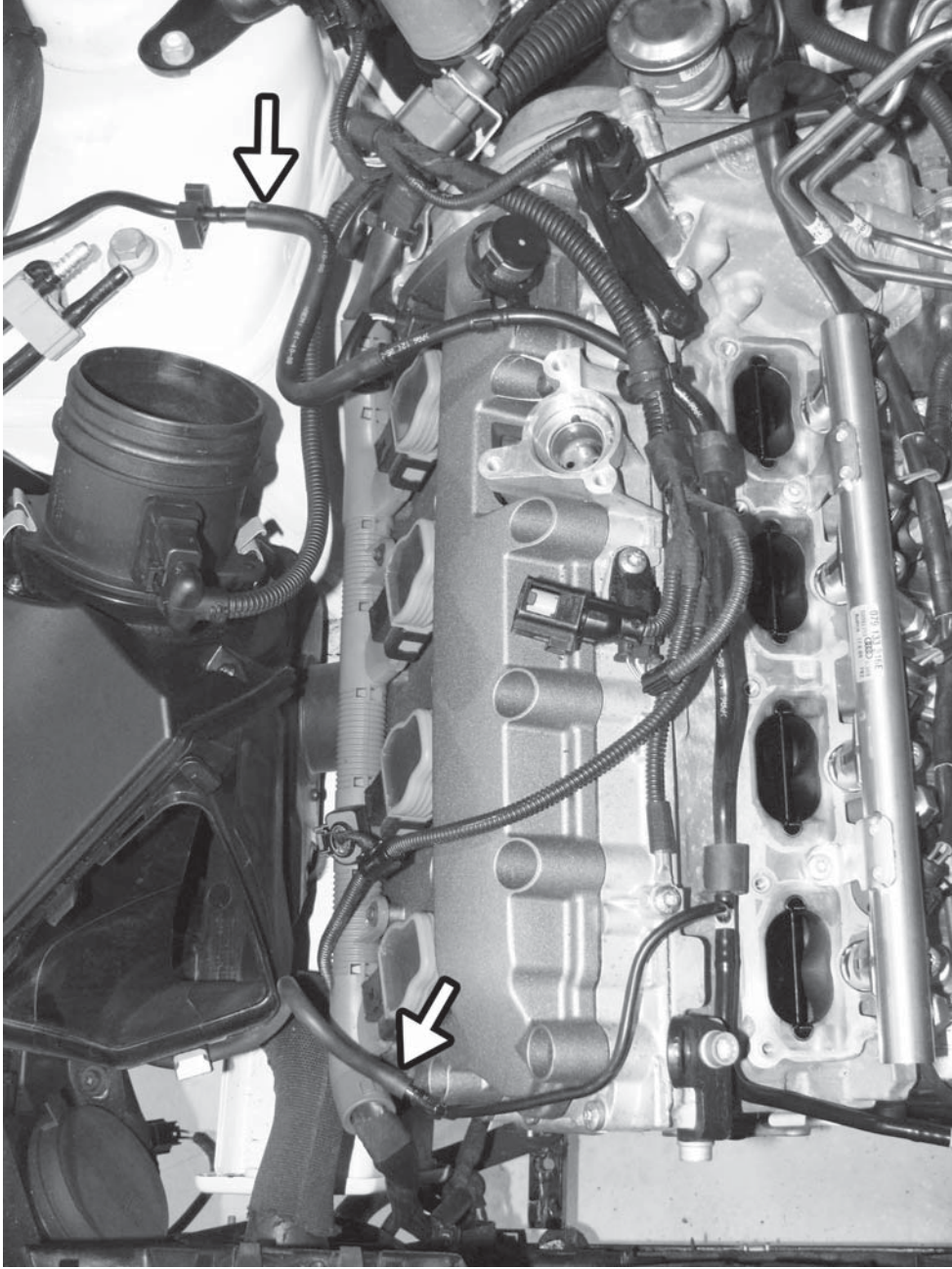

70) After unclipping the hard vacuum line from the front of the engine, cut the line just to the left side of the T fitting. Remove the entire vacuum line assembly which is connected to the two previously disconnected lines.

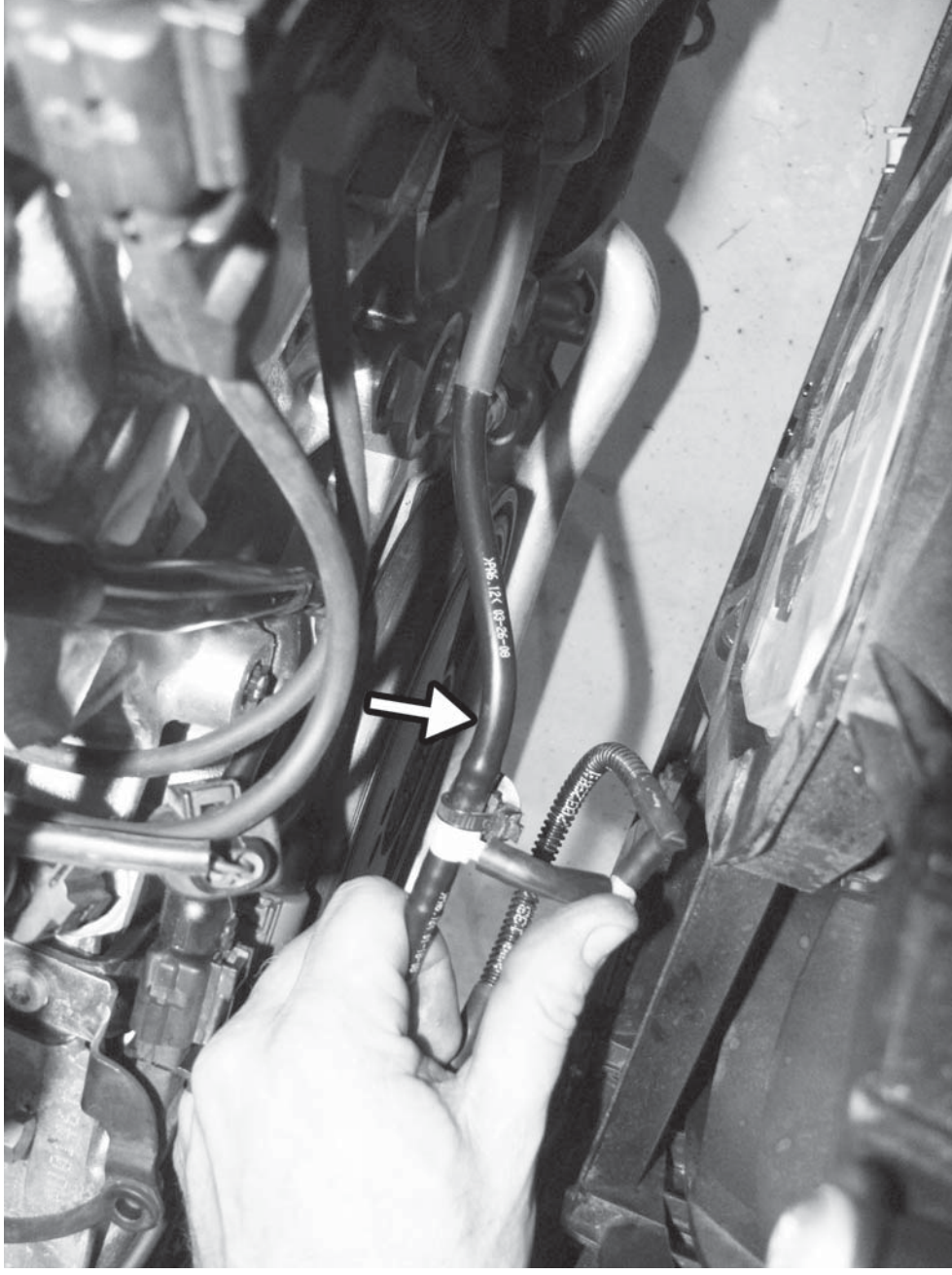

71) Reroute the hard plastic line from the vacuum canister up beside the left frame rail. Be sure to route it away from the exhaust manifold.

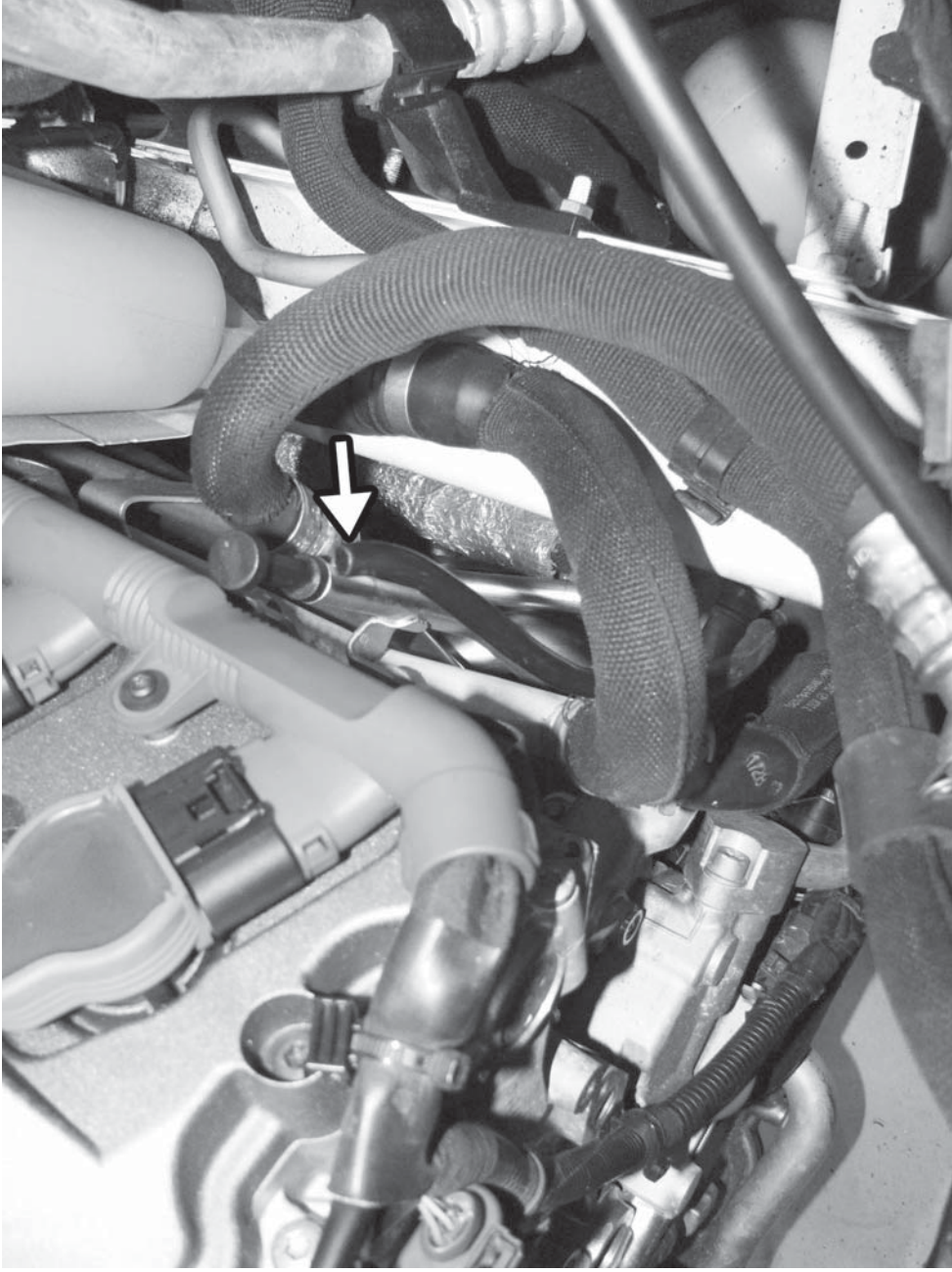

72) Remove the T30 screw and 14mm triple square bolt from the bracket holding the knock sensor connectors in place. Unplug the sensors and remove the connectors from the bracket.

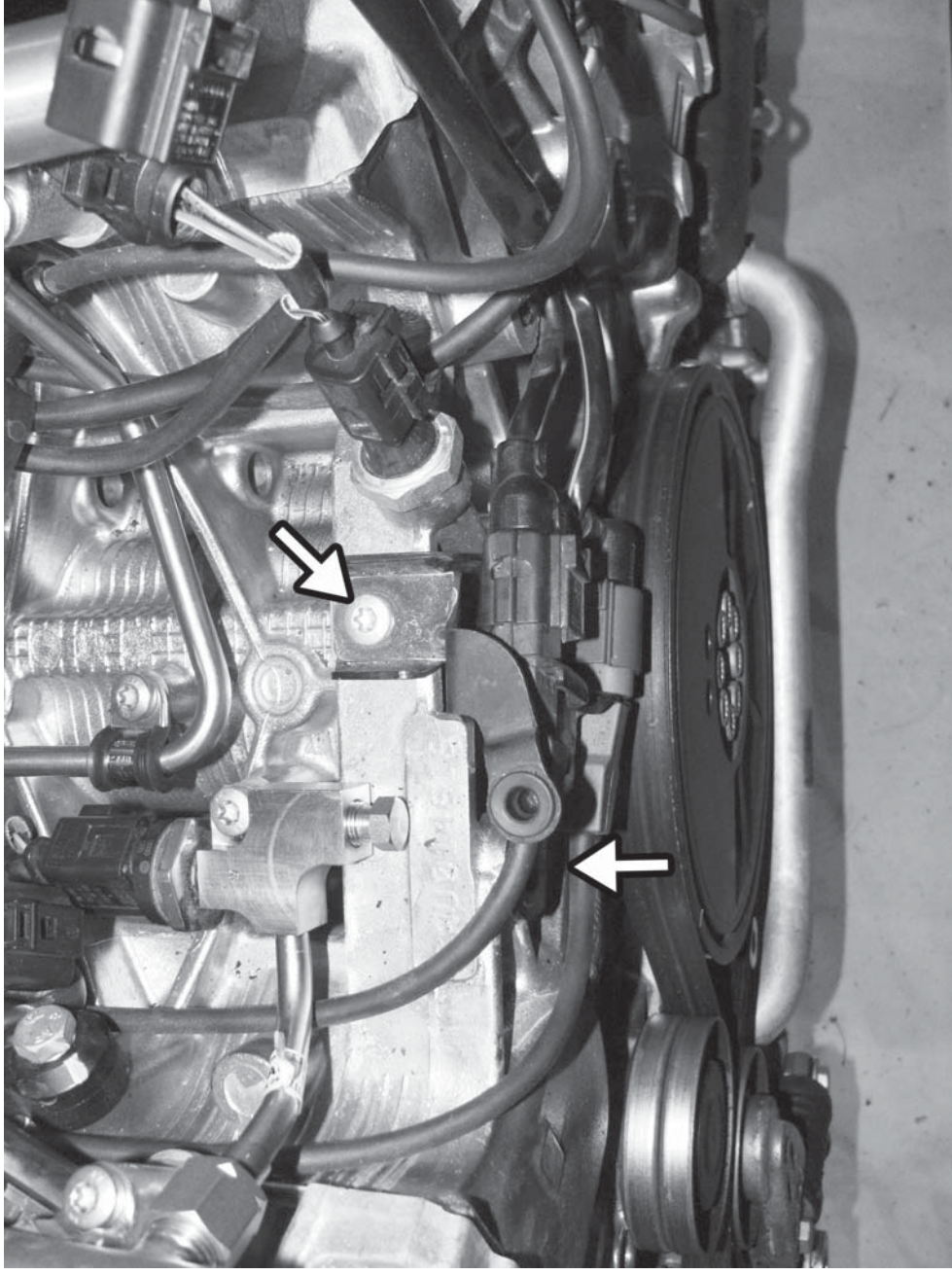

73) Route the two electrical connectors to the knock sensors behind the oil pressure sensor, towards the back of the crankcase valley.

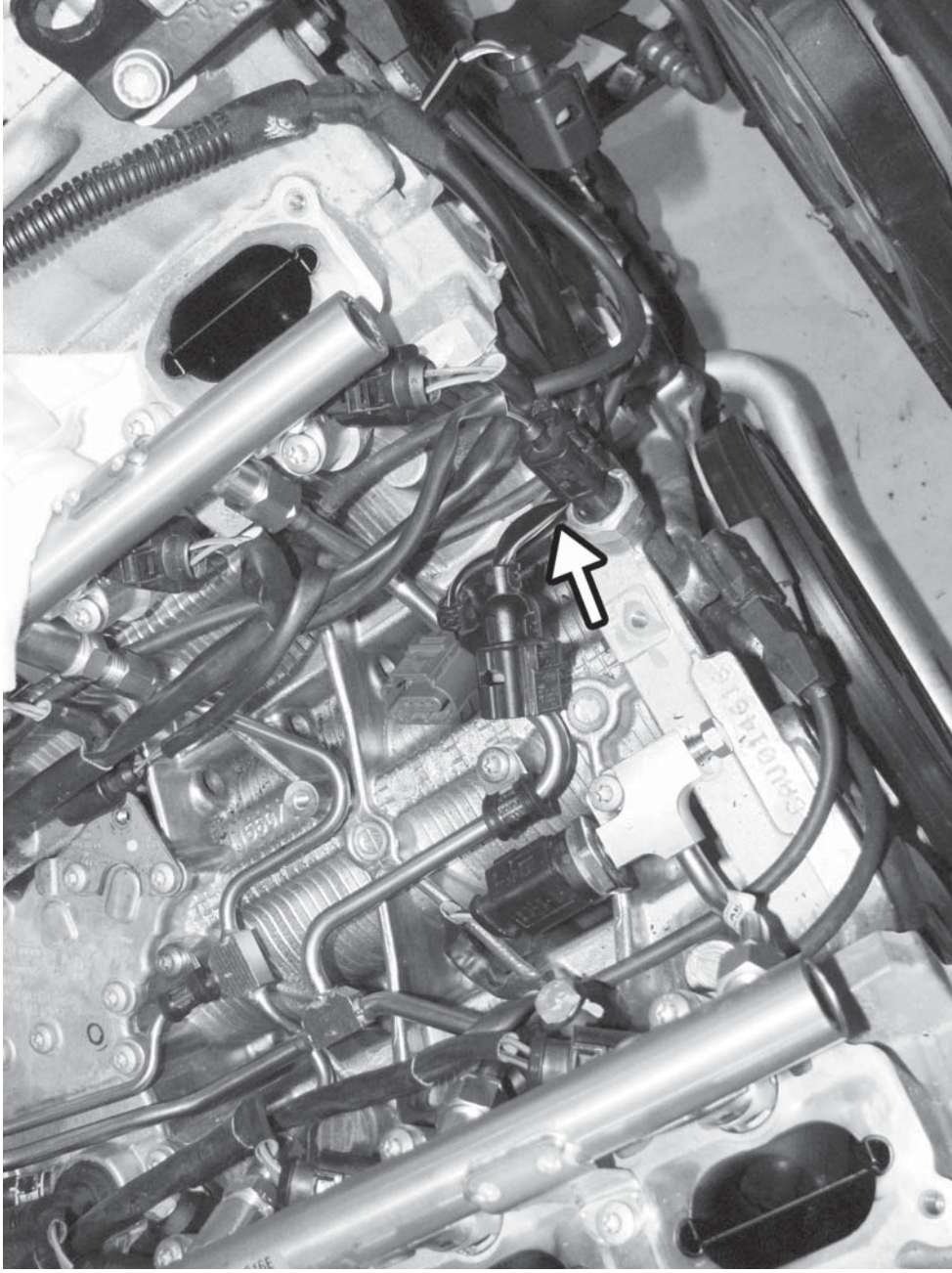

74) Reroute the knock sensor wiring from behind the forward fuel pressure sensor fuel line, and reconnect the knock sensors to their electrical connectors.

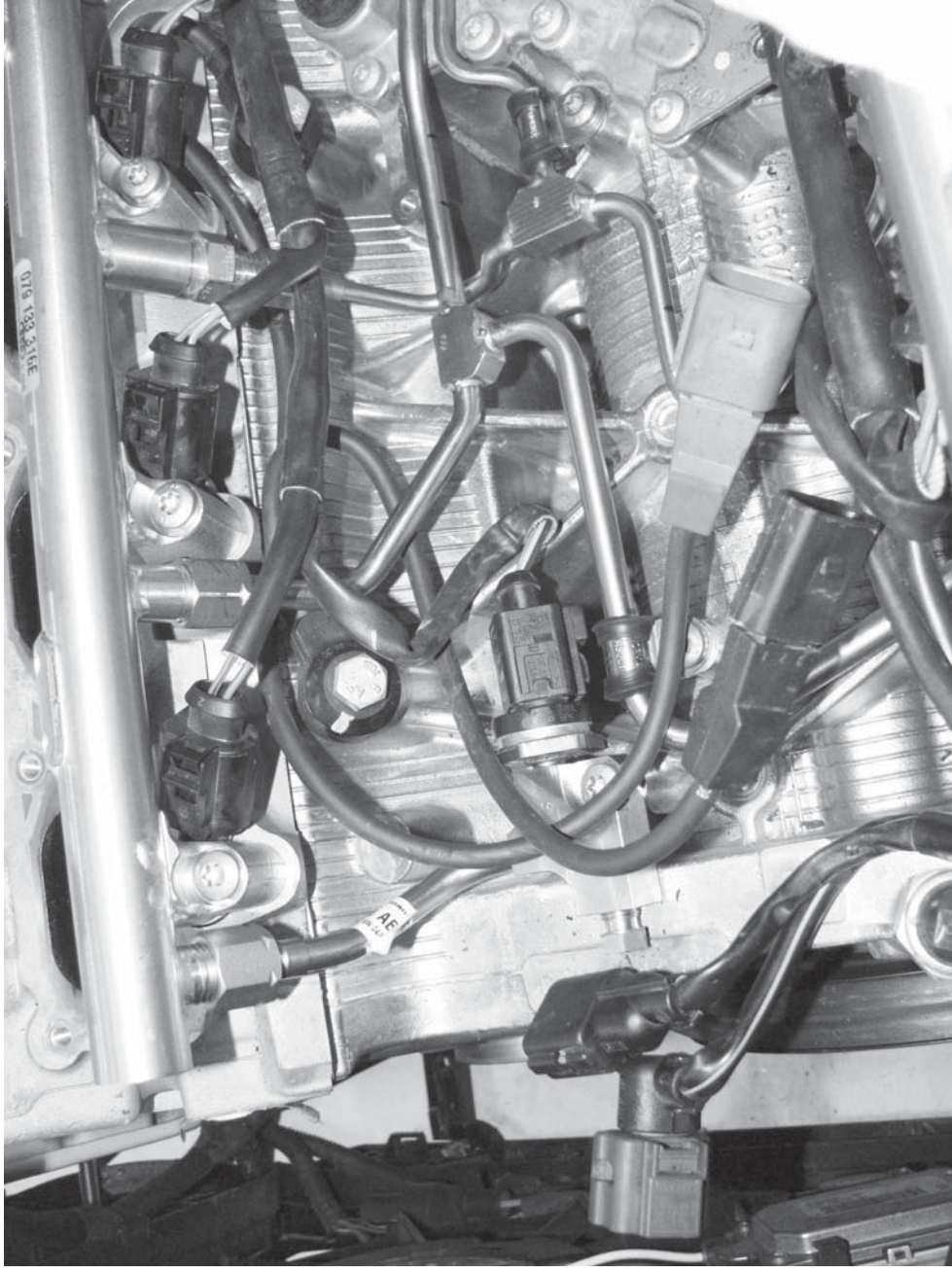

75) Route all four knock sensor wires under where the supercharger sits, and secure the wires with cable ties. The objective is to keep all wires away from the front of the engine to clear the supercharger belt and pulleys. Notice how close the lines are to the front left injectors. Foam tape is provided to wrap the wires to prevent chafing.

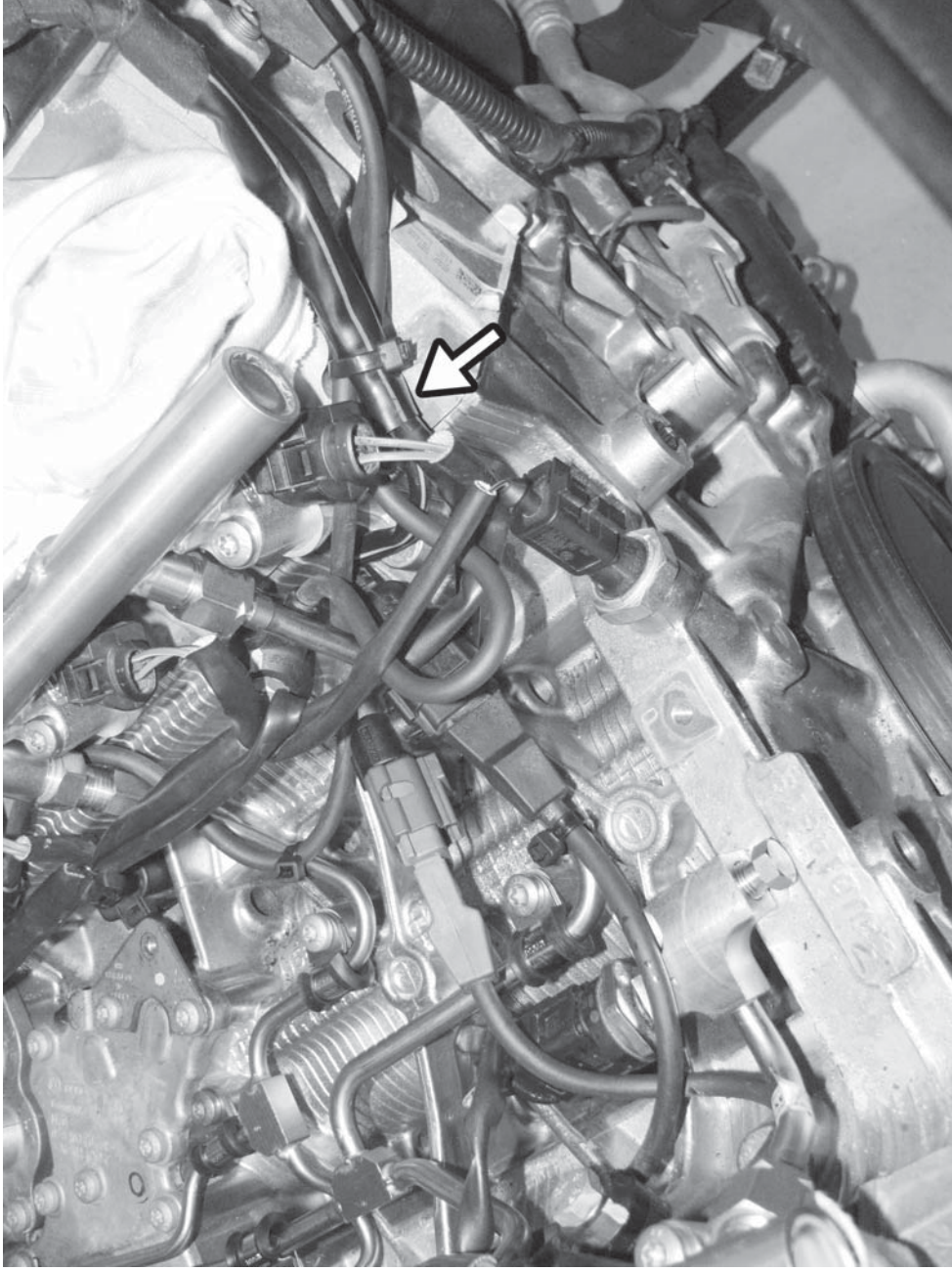

76) With a 3/8" square drive adaptor on the belt tensioner, remove the serpentine belt from the car by rotating clockwise and sliding the belt off.

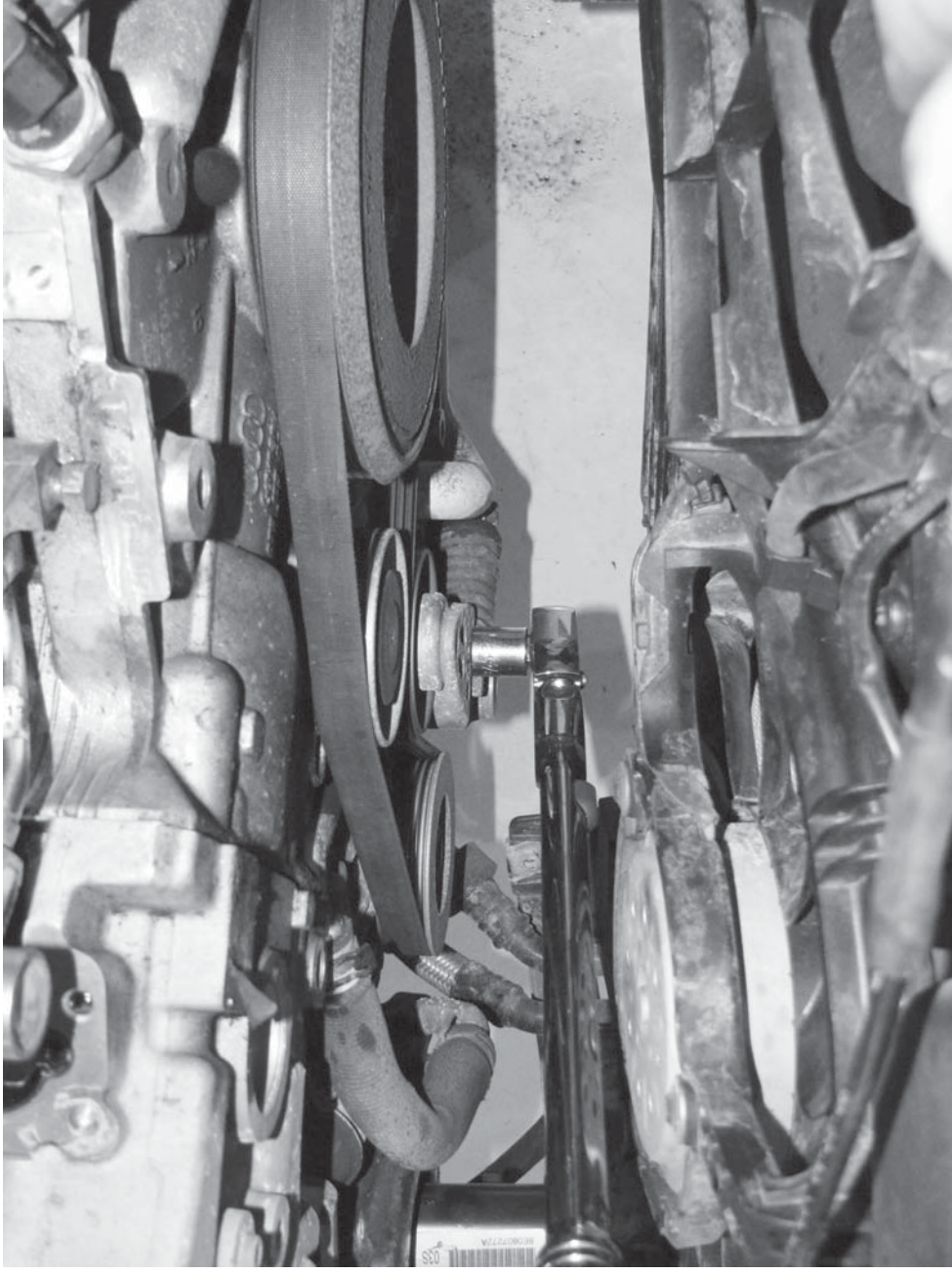

77) Install the supplied supercharger pulley bolts in the two bosses. Tighten them in place with a 24mm socket to 75Nm.

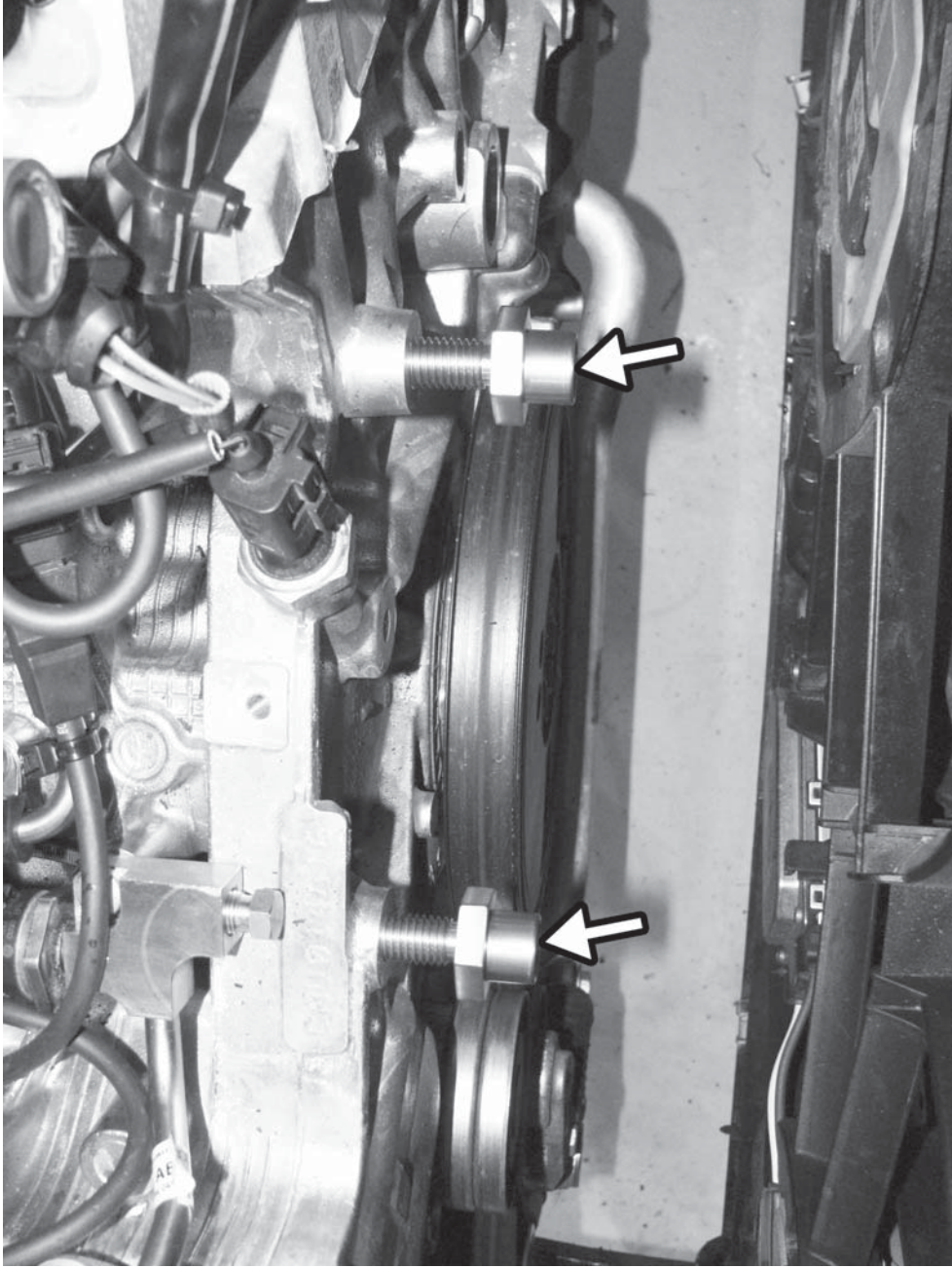

78) Install the two supplied idler rollers with the part numbers on the rollers facing away from the engine. Torque the 5mm allen bolts to 14Nm.

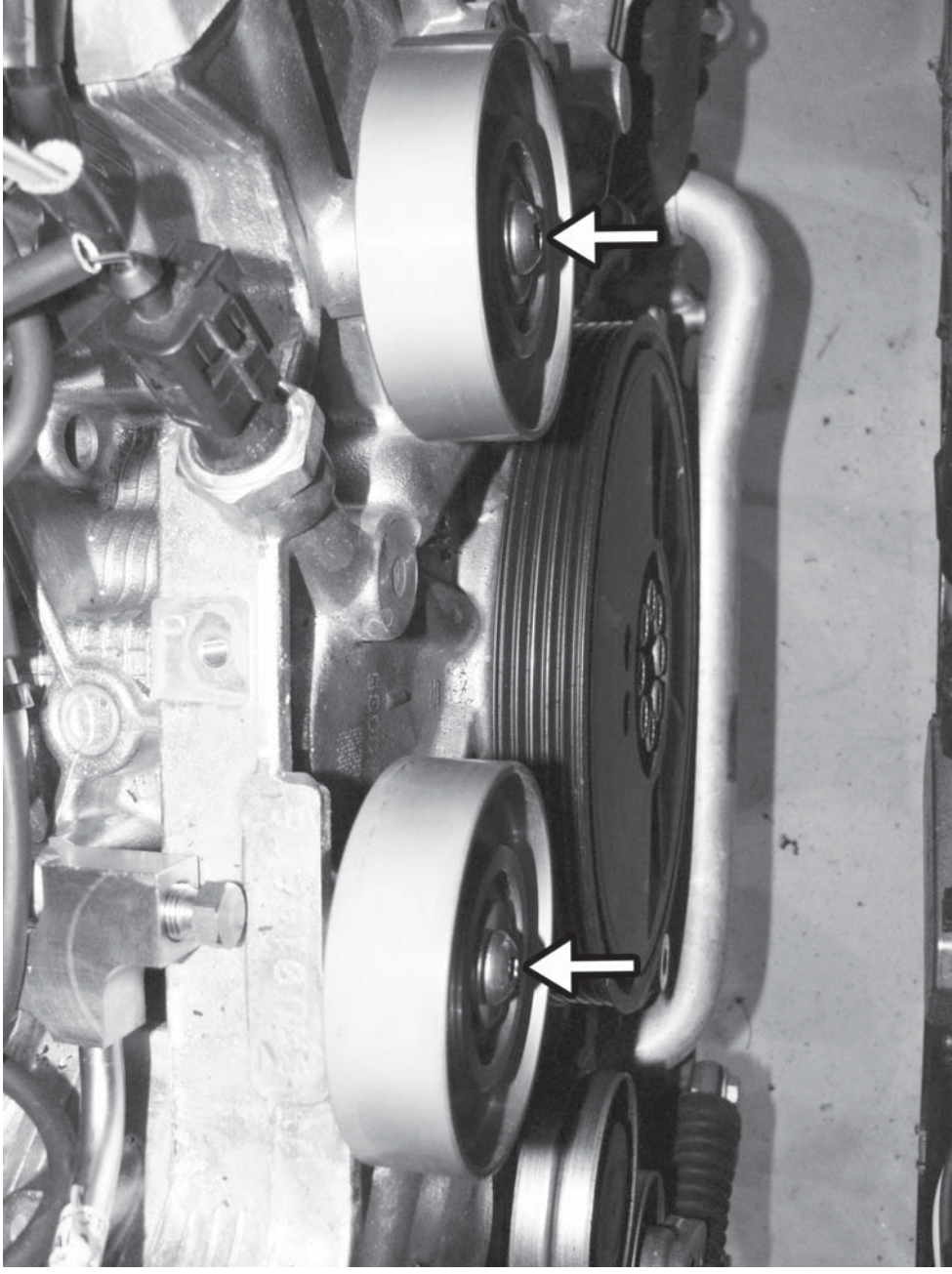

79) Remove the rubber hose section from the previously removed coolant hose.

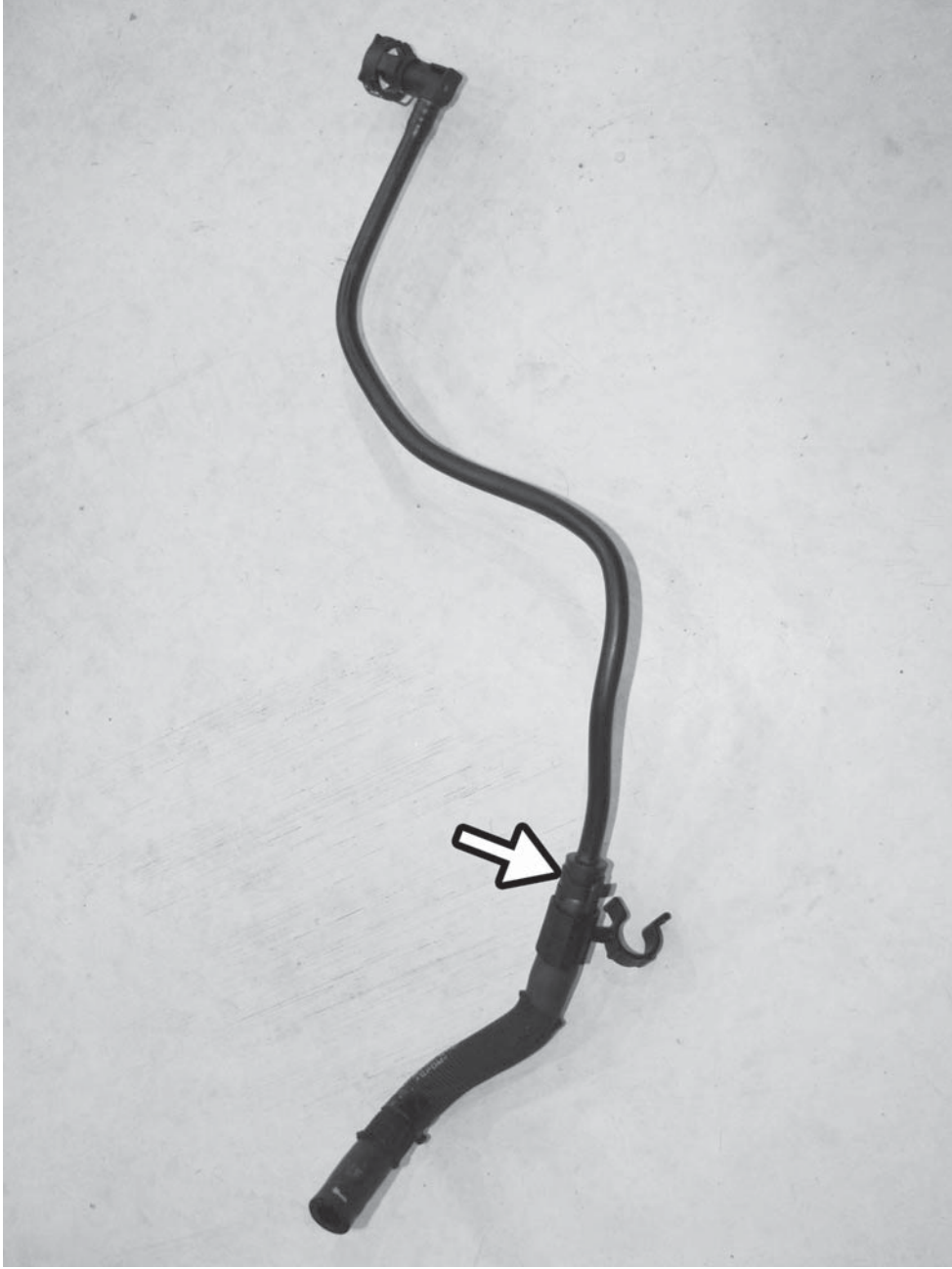

80) Remove the clamp and rubber coolant line from the metal coolant pipe on the back of the engine.

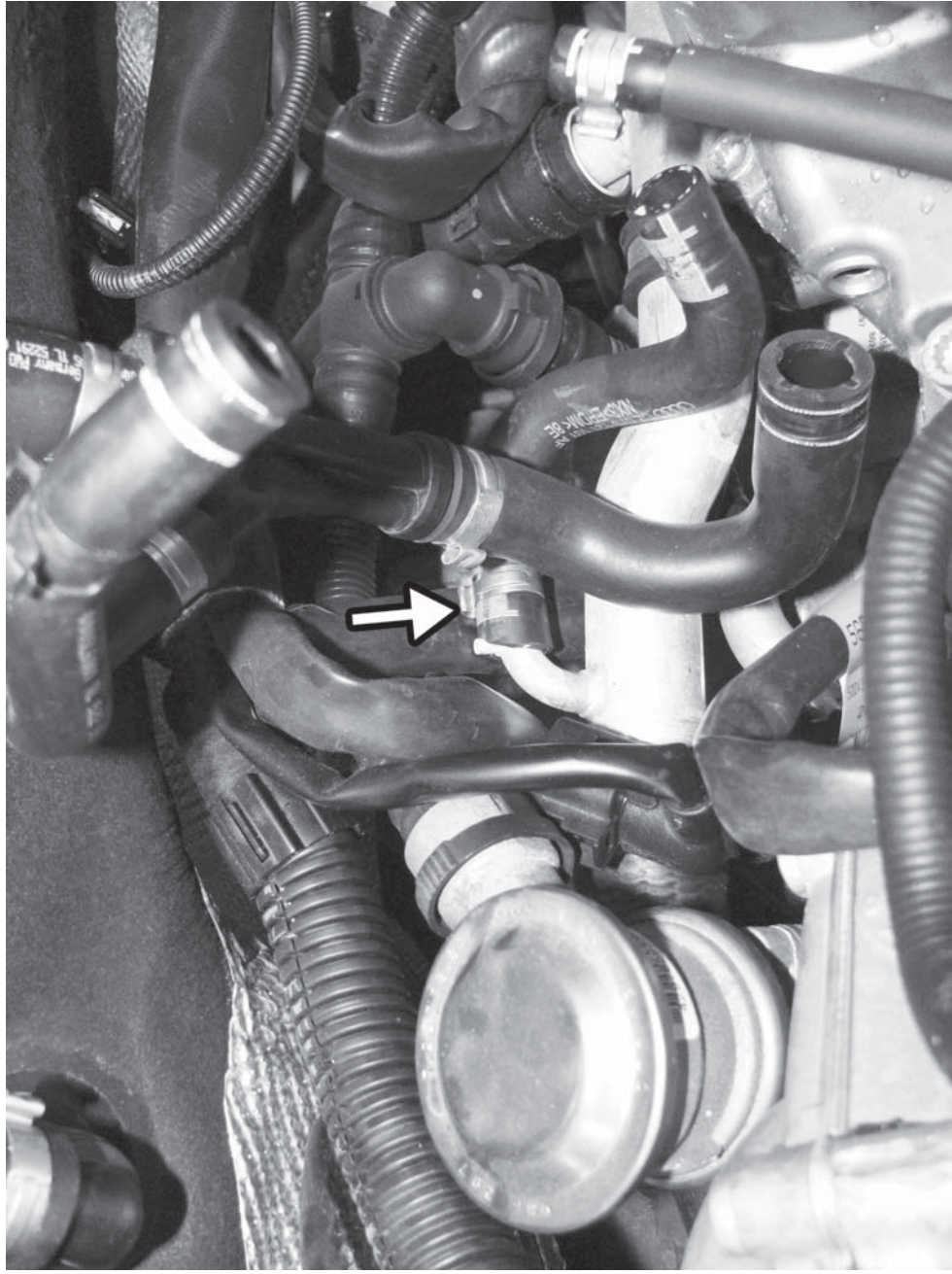

81) Install the supplied coolant hose on the plastic coolant pipe that connects to the reservoir with a hose clamp. After routing the hose behind the main wiring harness, connect it to the metal pipe on the back of the engine with a hose clamp. Reconnect the coolant hose to the coolant reservoir.

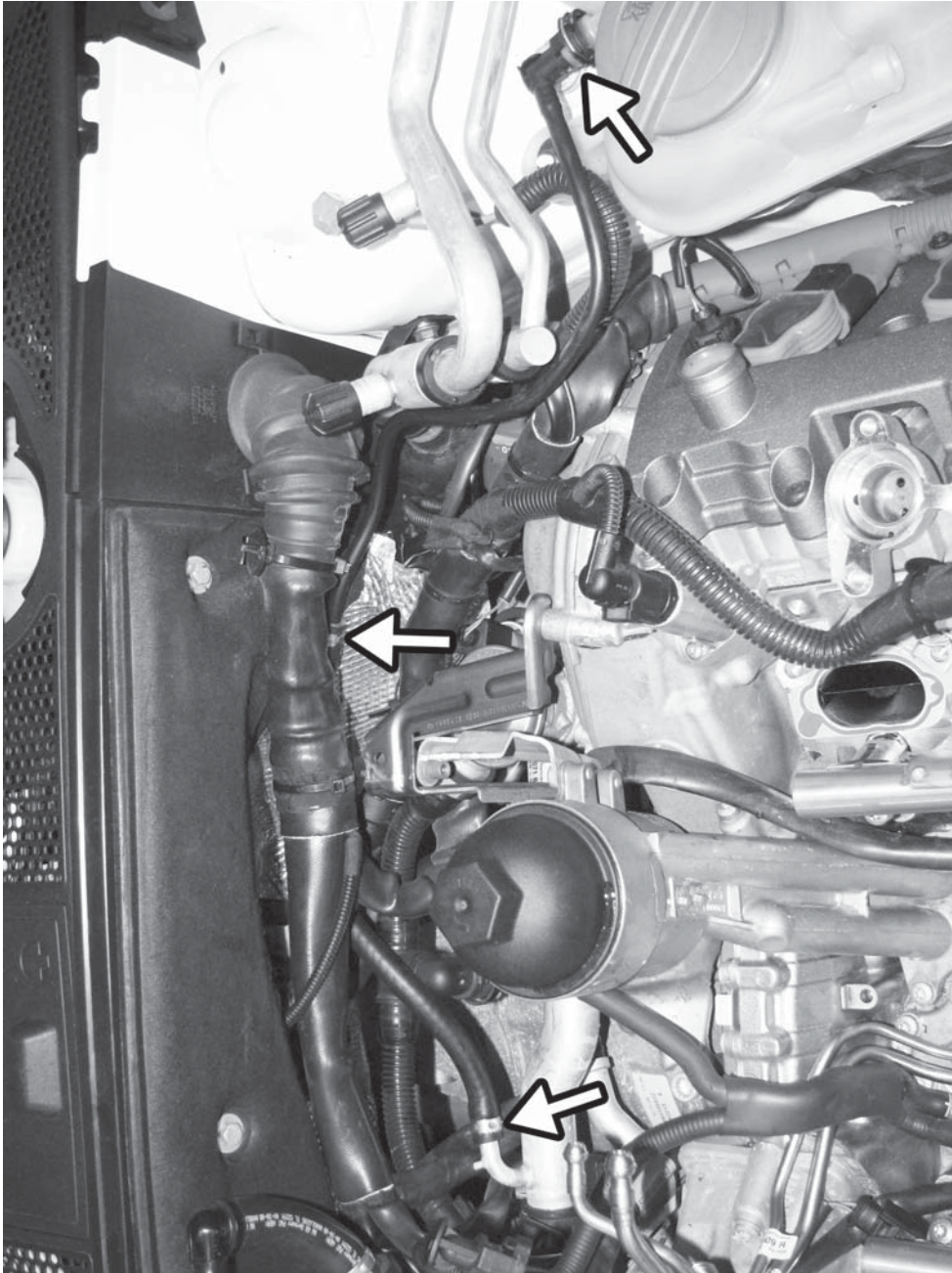

82) Remove the two T30 screws from the N80 mounting bracket and remove the bracket from the engine.

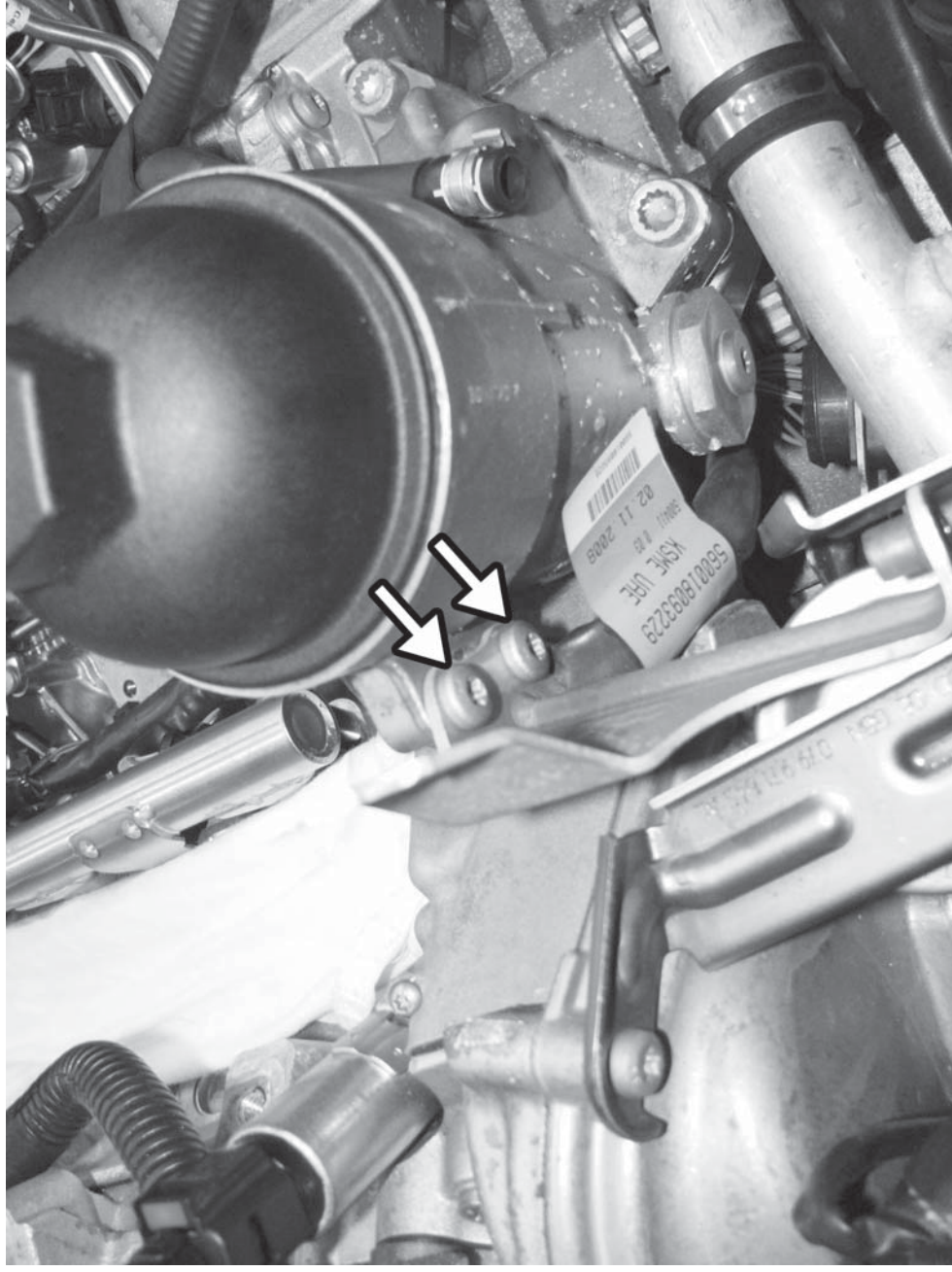

83) Install the supplied Intake Air Temperature sensor into the manifold with the 5mm allen bolt and lockwasher.

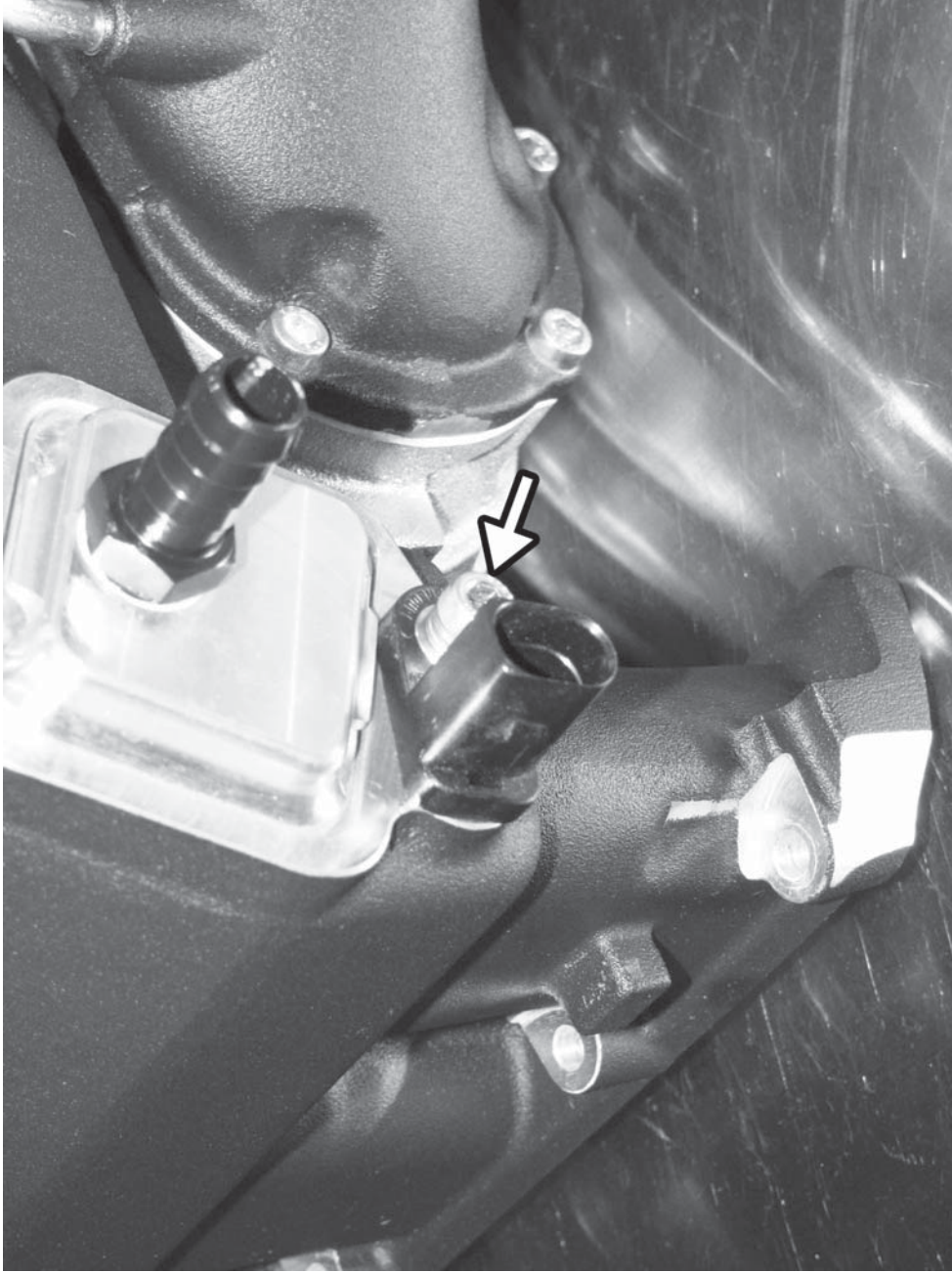

84) Remove the two T25 screws from the oil separator and remove the separator from the stock manifold.

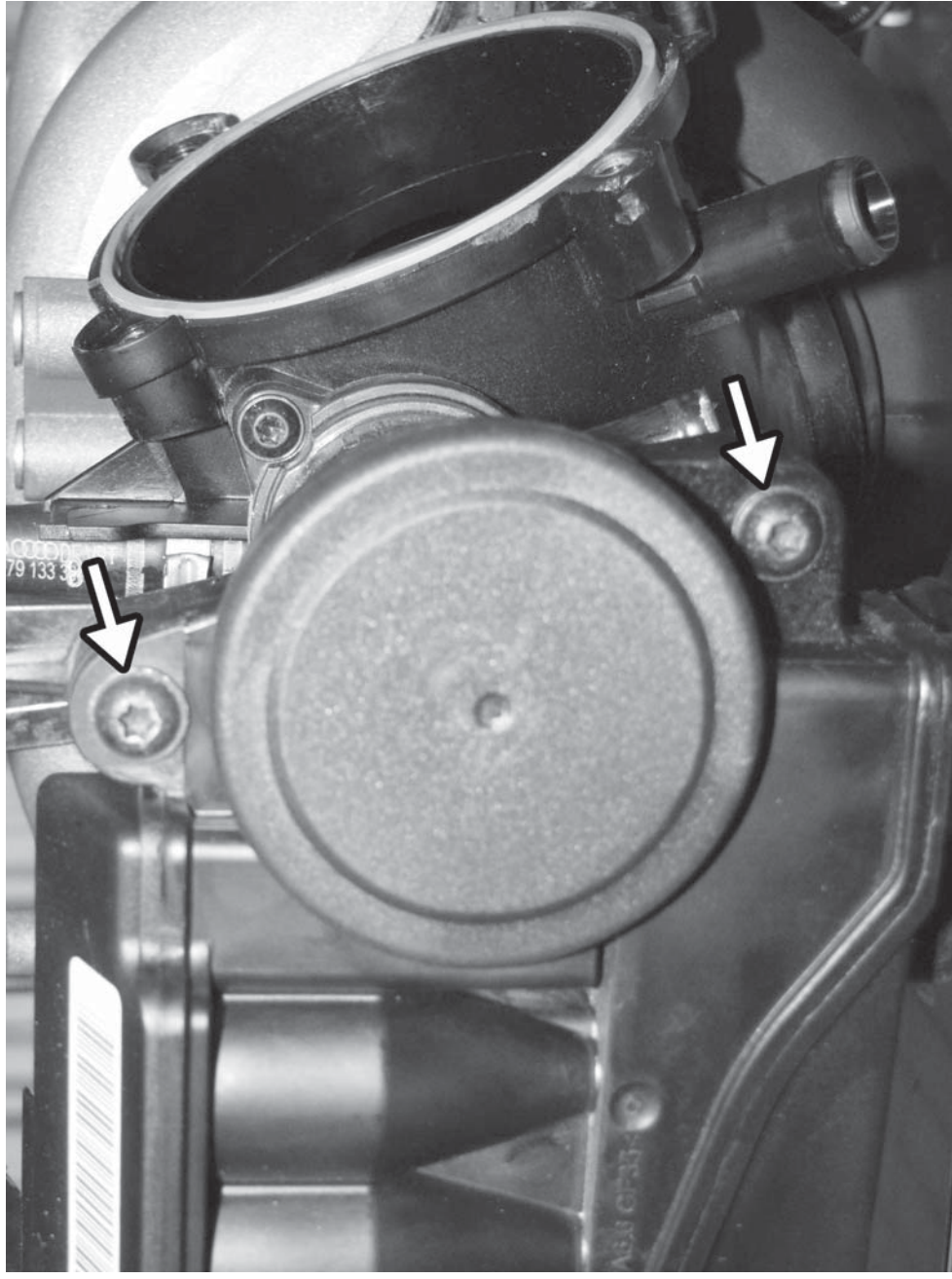

85) Install the oil separator on the supercharger assembly with the supplied coolant reservoir bracket, 5mm allen screws, and lockwashers.

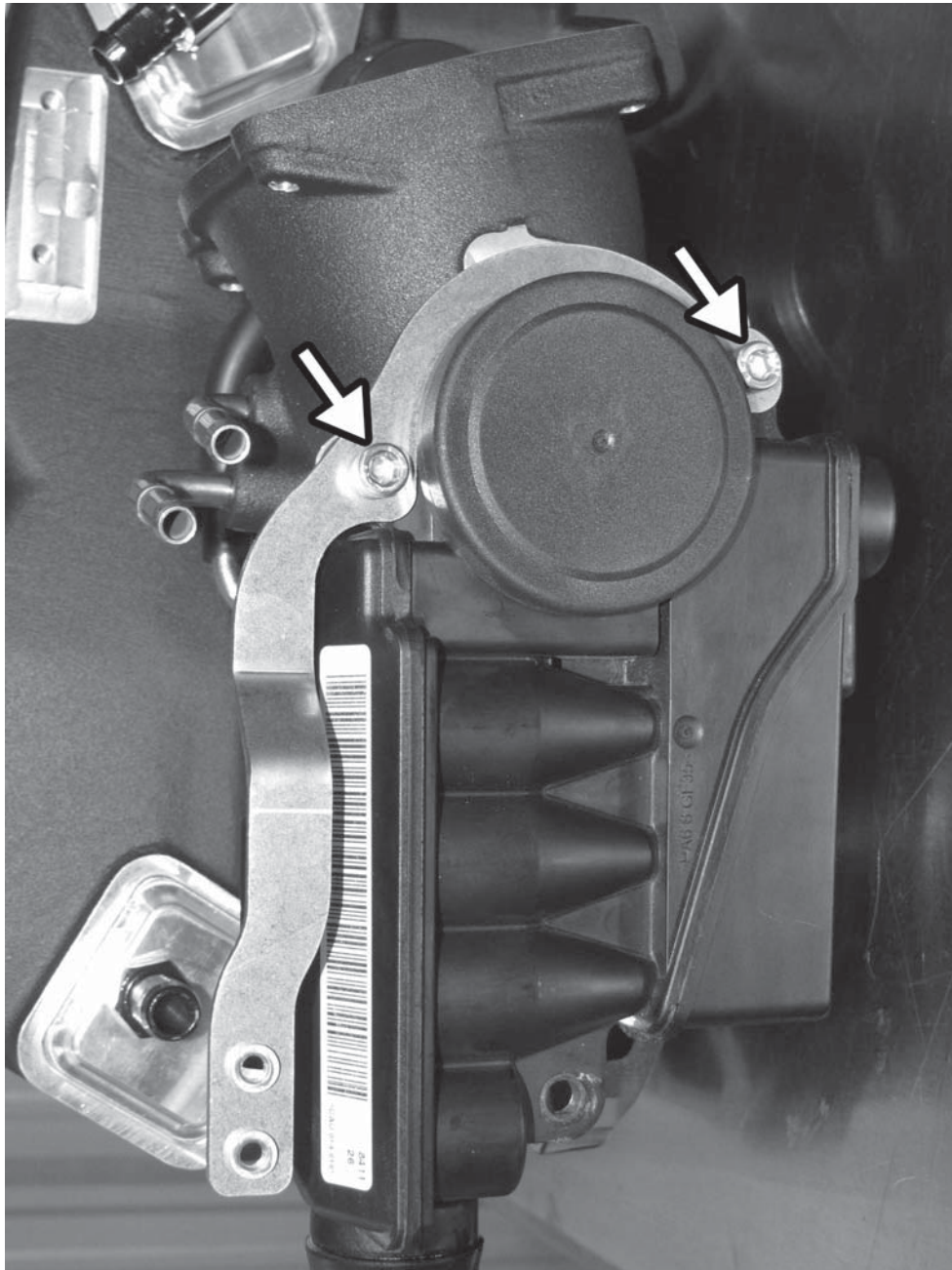

86) After removing the three 10mm triple square bolts, remove three of the engine hoisting brackets, leaving only the left front bracket.

After cleaning the crankcase valley one last time, remove the rags and set the intake manifold gaskets in place.

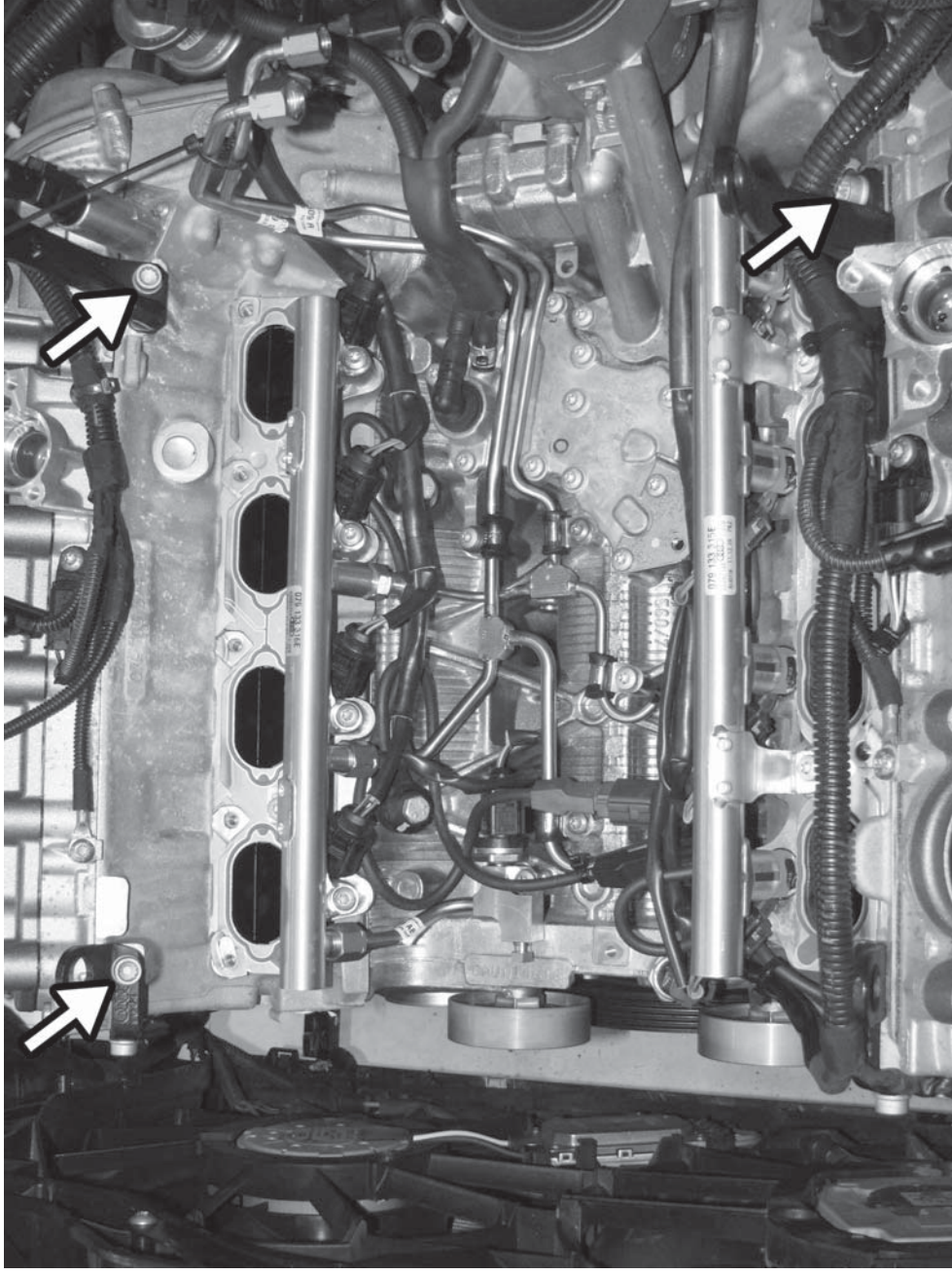

87) The electrical connector for the runner flap actuator can be routed back along the left wiring harness and cable tied out of the way.

Ensure everything is out of the way for the supercharger install. All lines, wires, hoses, etc., should be securely fastened and clear of the belt and pulley area.

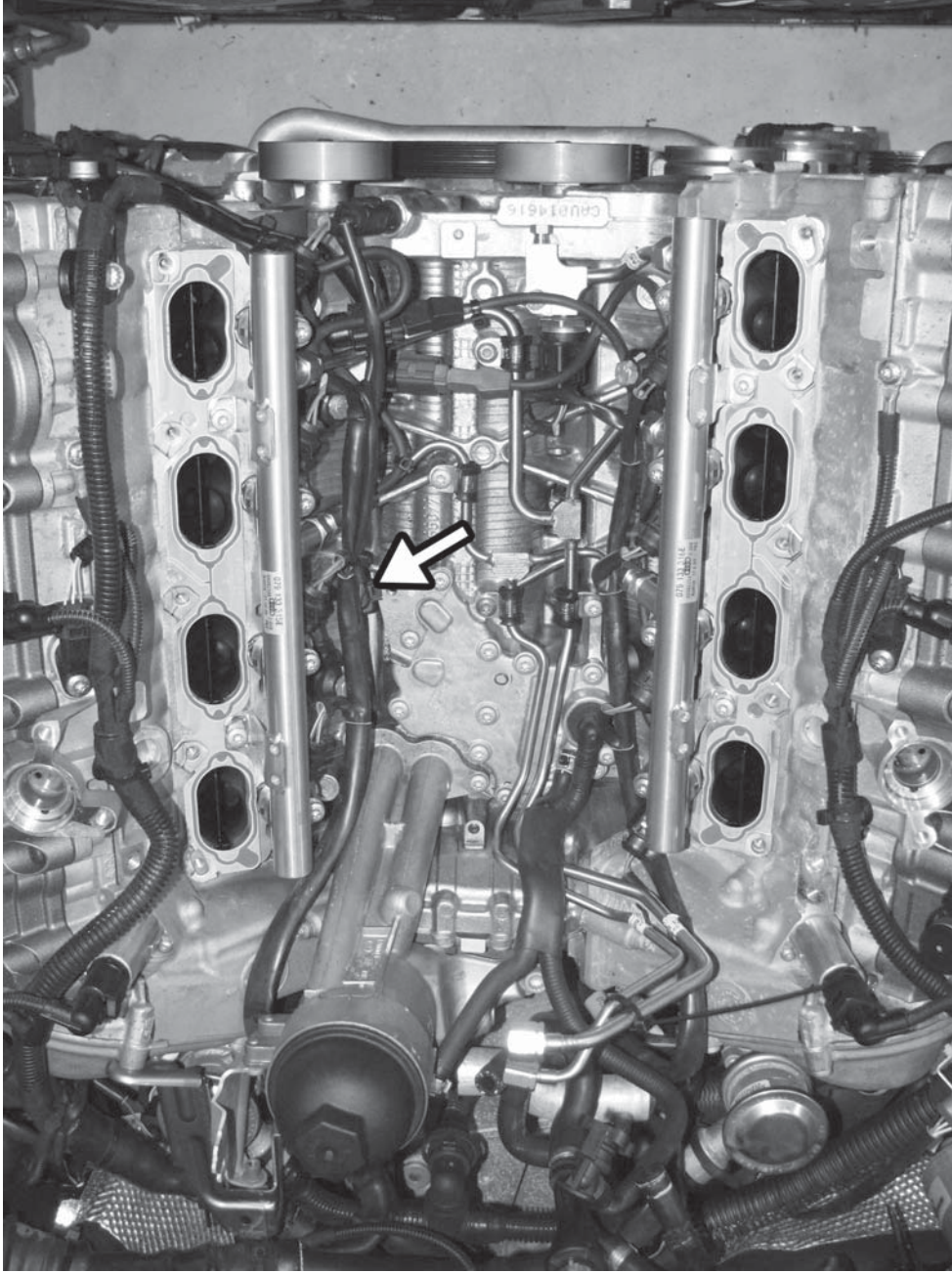

88) Being careful around the two fuel lines sticking up from the fuel rails, carefully set the supercharger near its final location. Connect the drain line to the oil separator along with the vacuum hose for the suction jet. Secure both hoses with the supplied clamps.

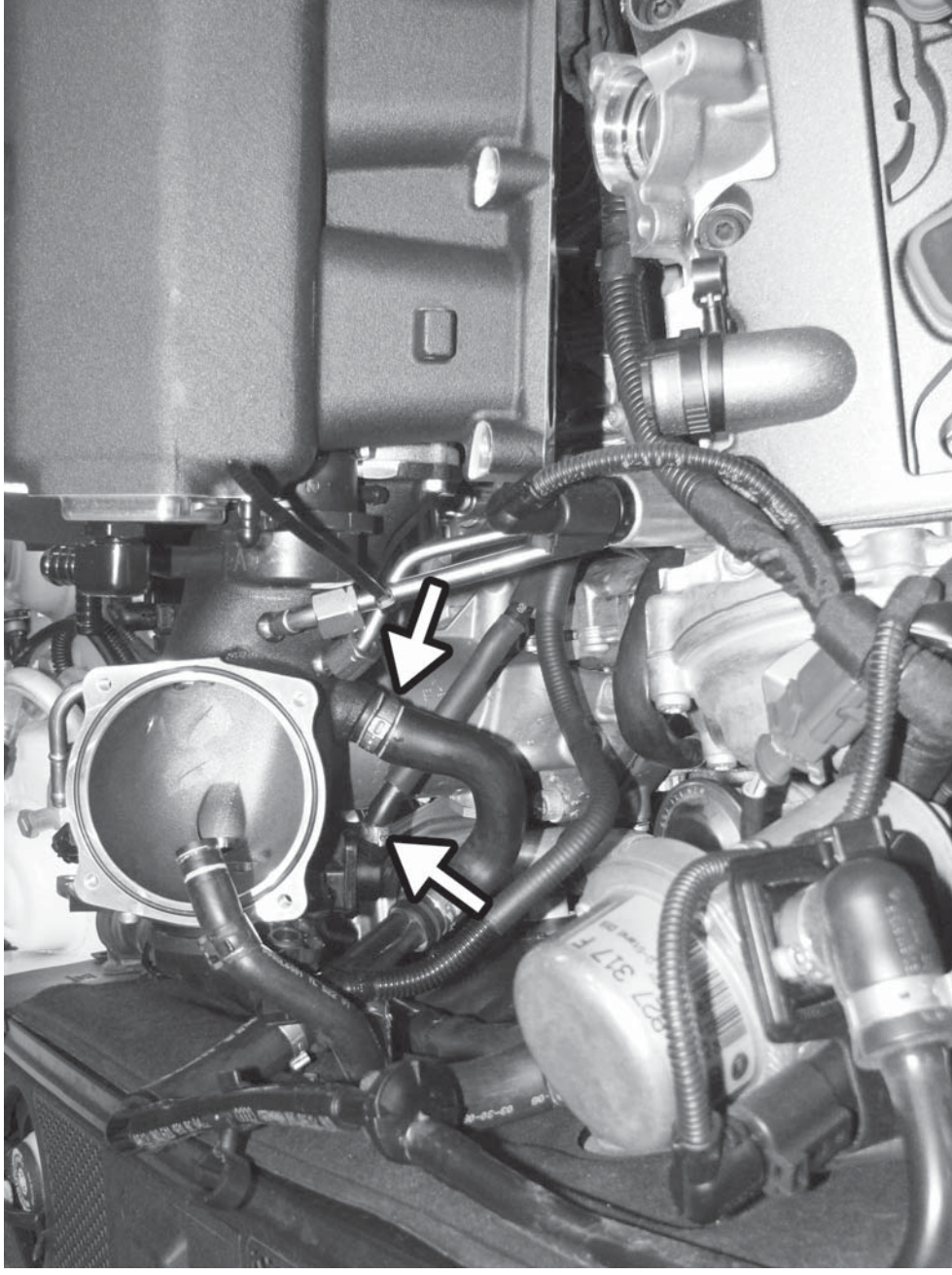

89) Carefully lower the supercharger down onto the gaskets. Make sure the wiring harnesses on both sides of the manifold lay freely between the supercharger and the cylinder heads.

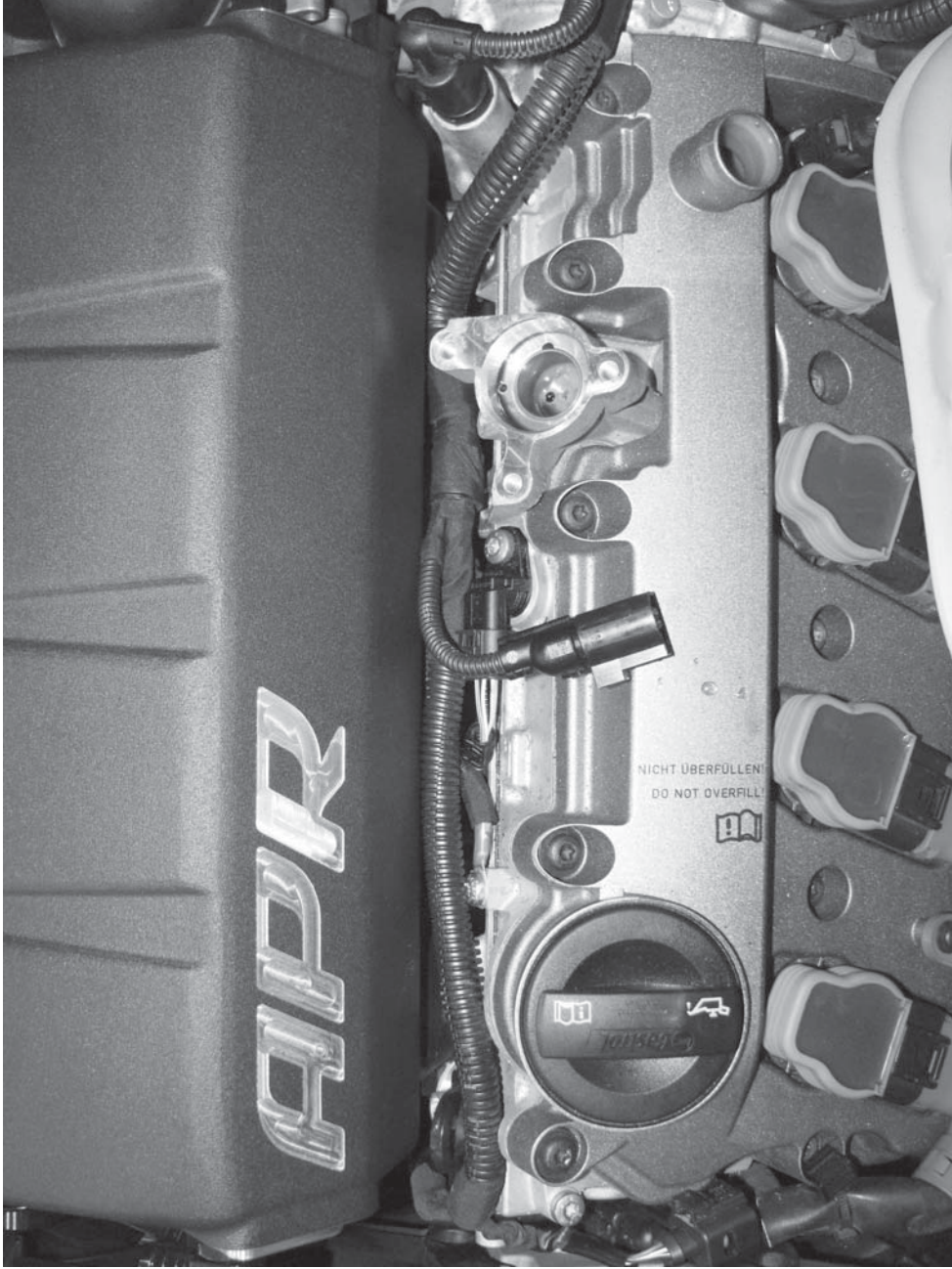

90) Place some painters tape along the side of the manifold to help prevent scratches before loosely installing the ten M5 allen screws and lockwashers. If the gaskets and supercharger are correctly aligned, the screws should be able to be hand threaded in place.

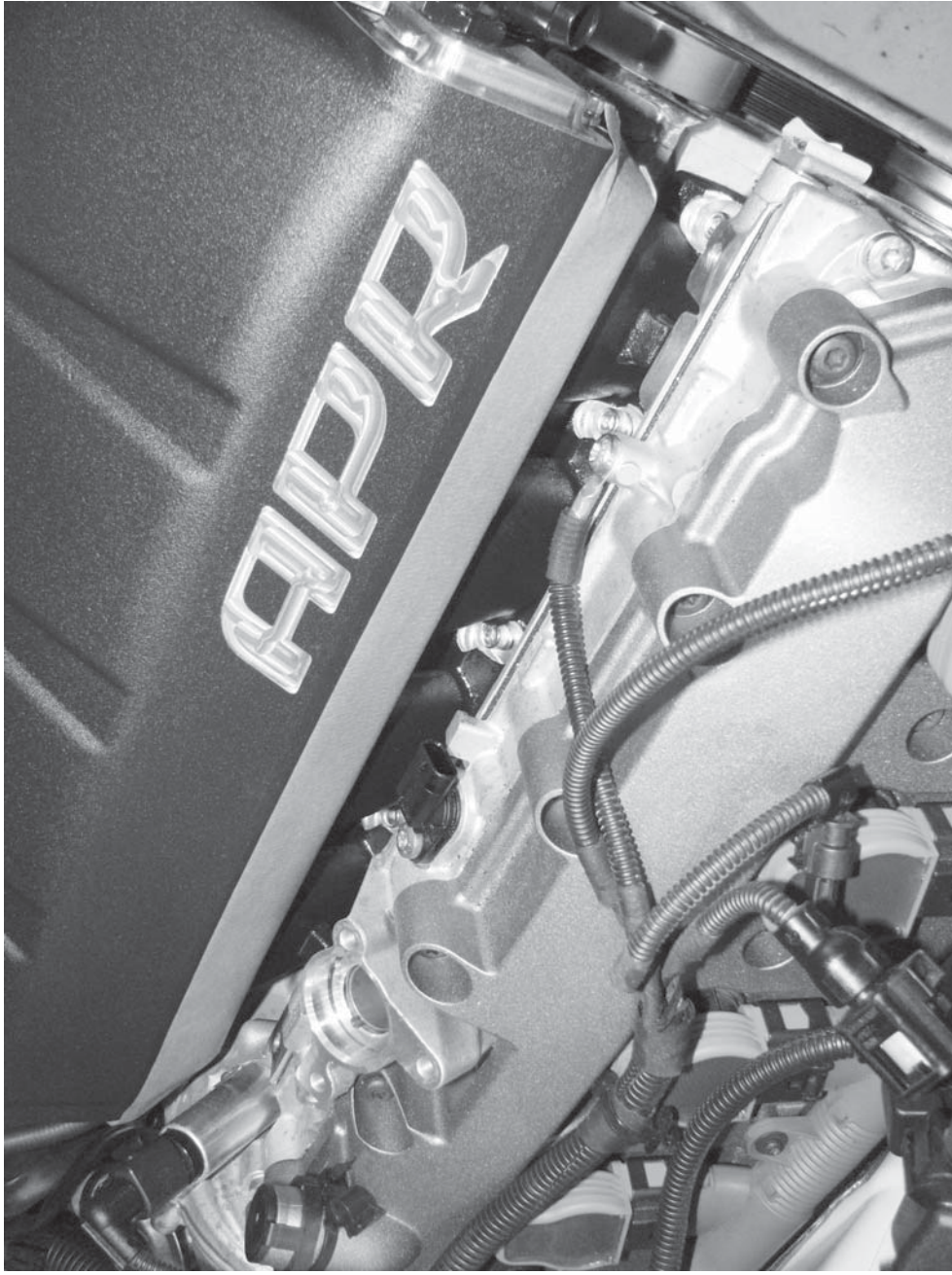

91) Tighten all ten 5mm allen screws with the supplied tool. Work in a crisscross pattern from side to side, starting from the center of the manifold going towards the ends. The process will need to be repeated several times to before the supercharger is fully tightened.

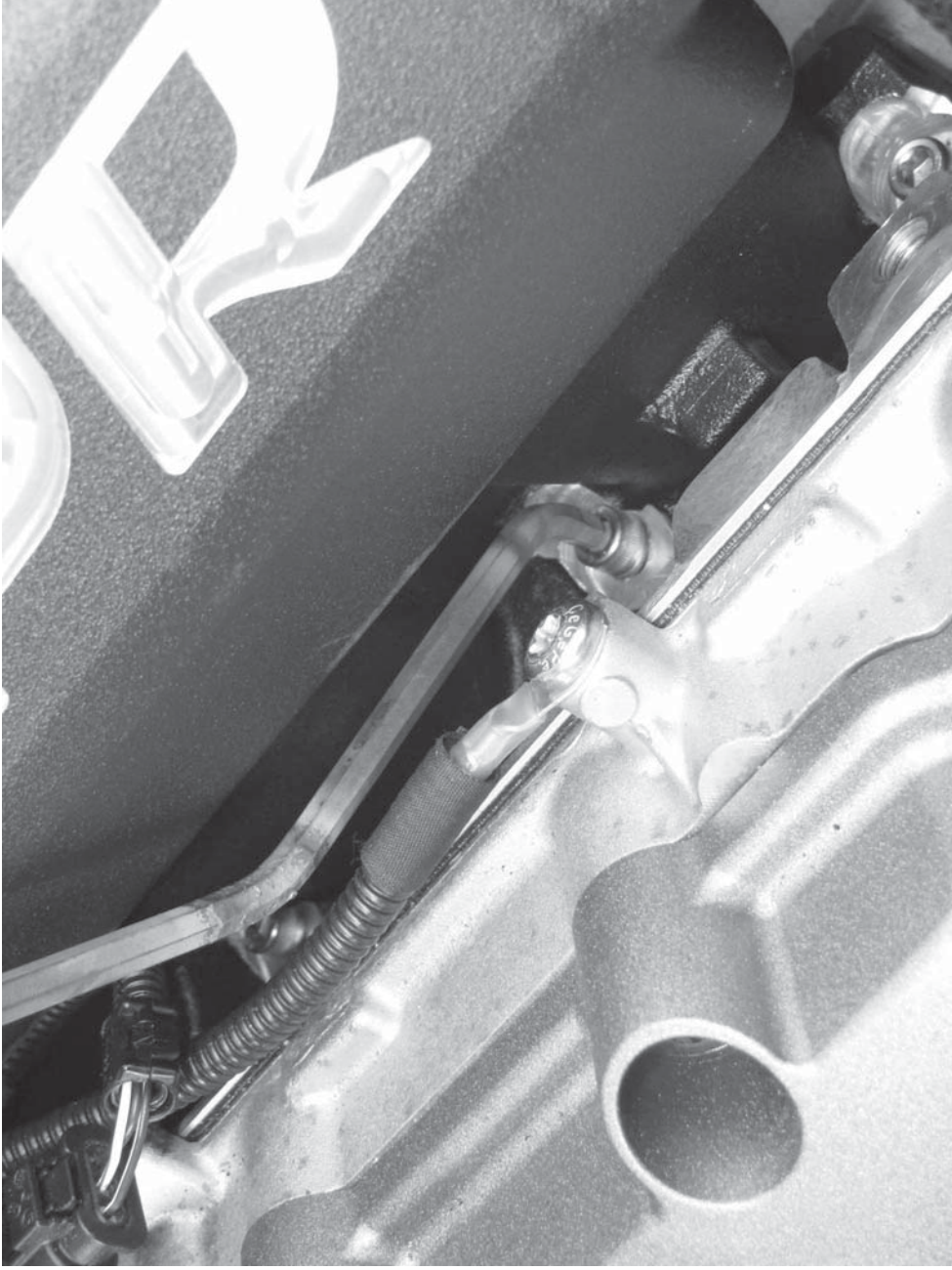

92) Install the supplied belt by using a 3/8" square drive adaptor on the belt tensioner and rotating the tensioner clockwise.

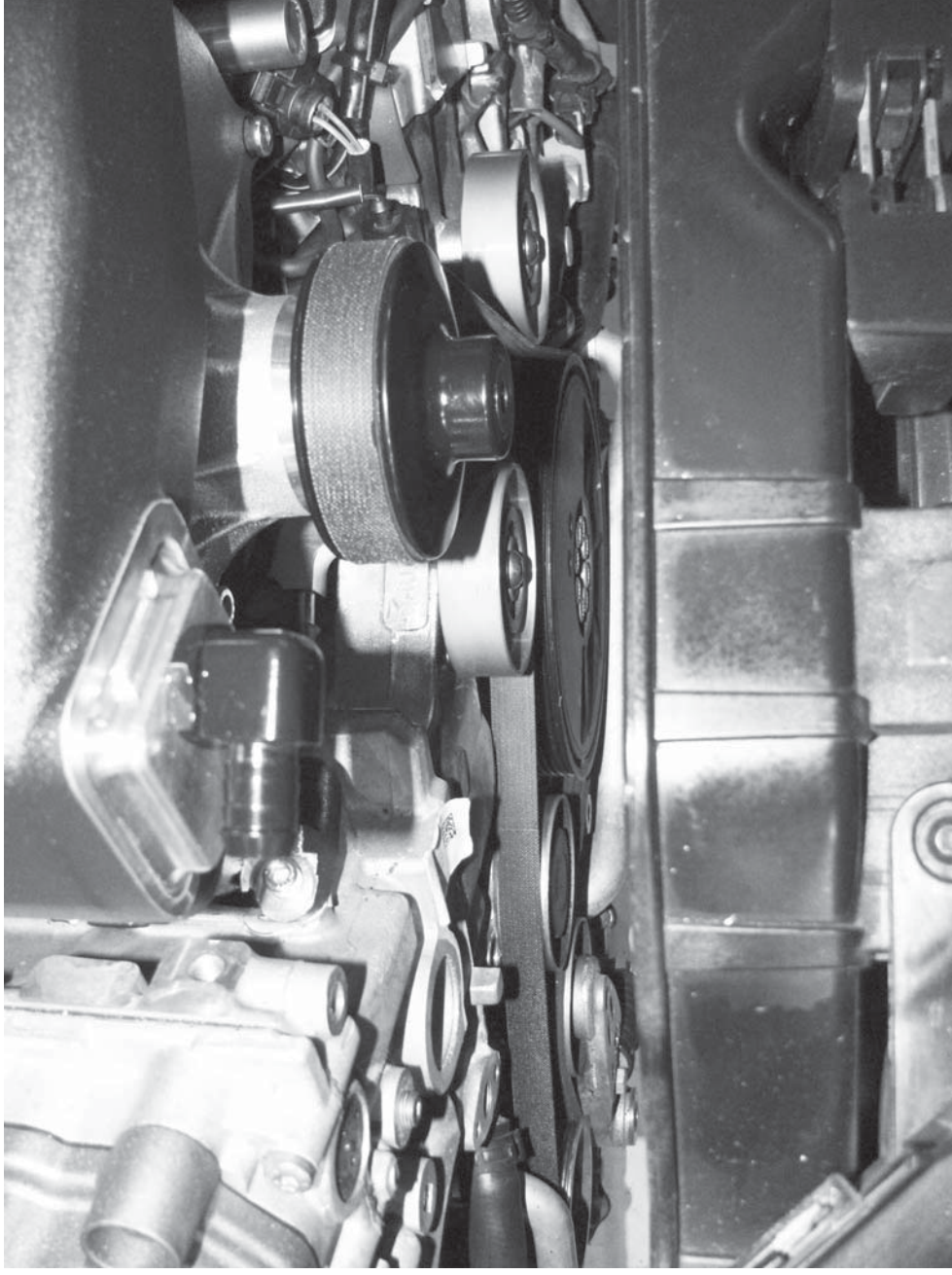

93) Install the throttle body as shown with the supplied 5mm allen bolts and lockwashers. Reconnect the electrical connector to the throttle body. It may be necessary to rotate the angled housing of the electrical connector.

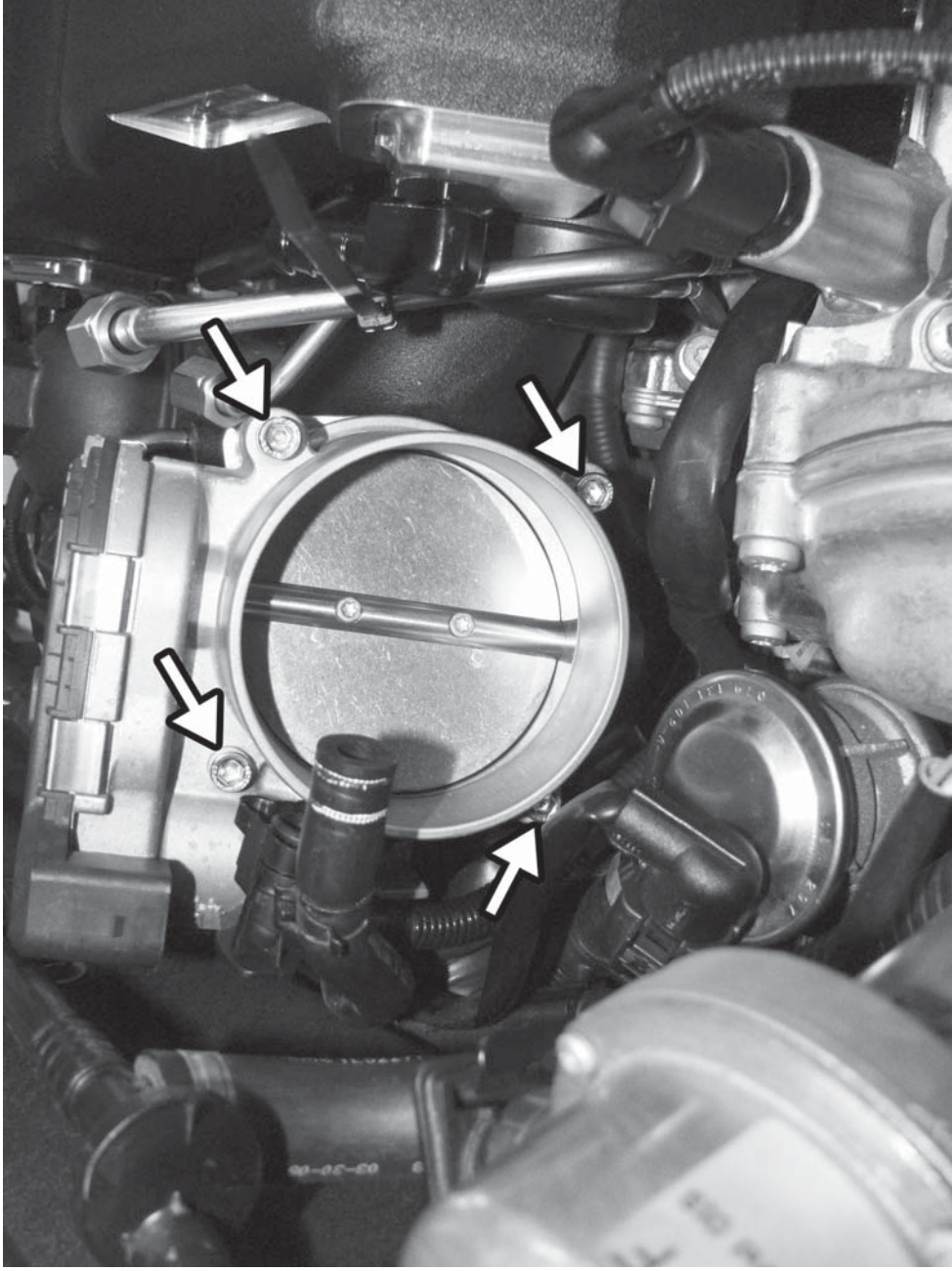

94) Remove the N80 valve from the OEM hose.

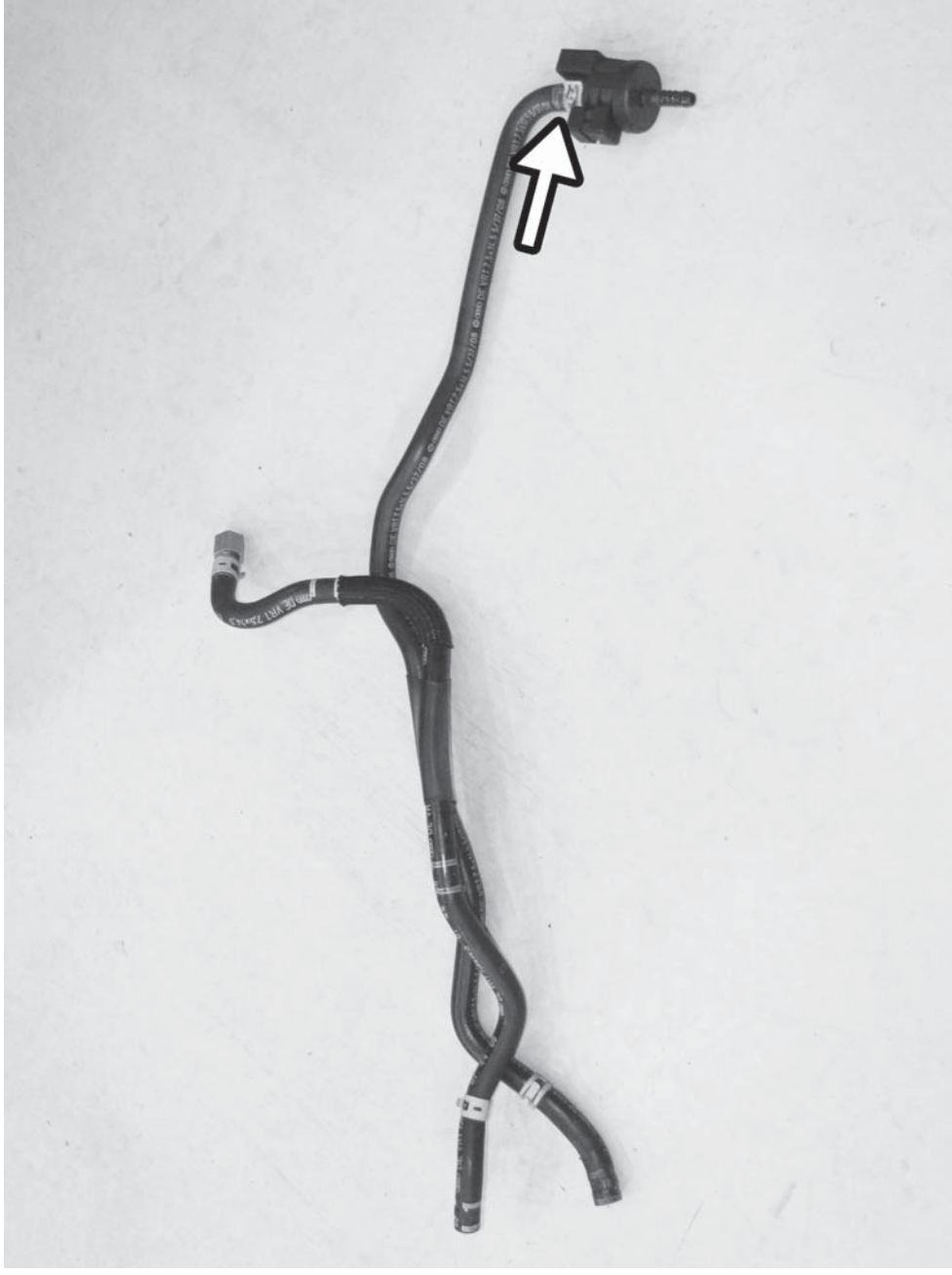

95) Install the APR supplied hoses on either side of the N80 with clamps. Noting that the arrow on the N80 should point towards the engine, connect the N80 assembly to the lower port on the hard line on the shock tower.



96) Connect the N80 extension harness to the N80 valve. Route both the harness and the N80 line behind the throttle body. Connect the extension harness to the original N80 connector, and connect the vacuum line to the upper right barb coming out of the supercharger inlet with a clamp. Secure both lines to each other with cable ties.



97) Install the supplied vacuum hose to the previously rerouted line that connects to the vacuum canister. Route the hose to the back of the airbox, going behind the ABS pump, alongside the air conditioning lines, and behind the throttle body.

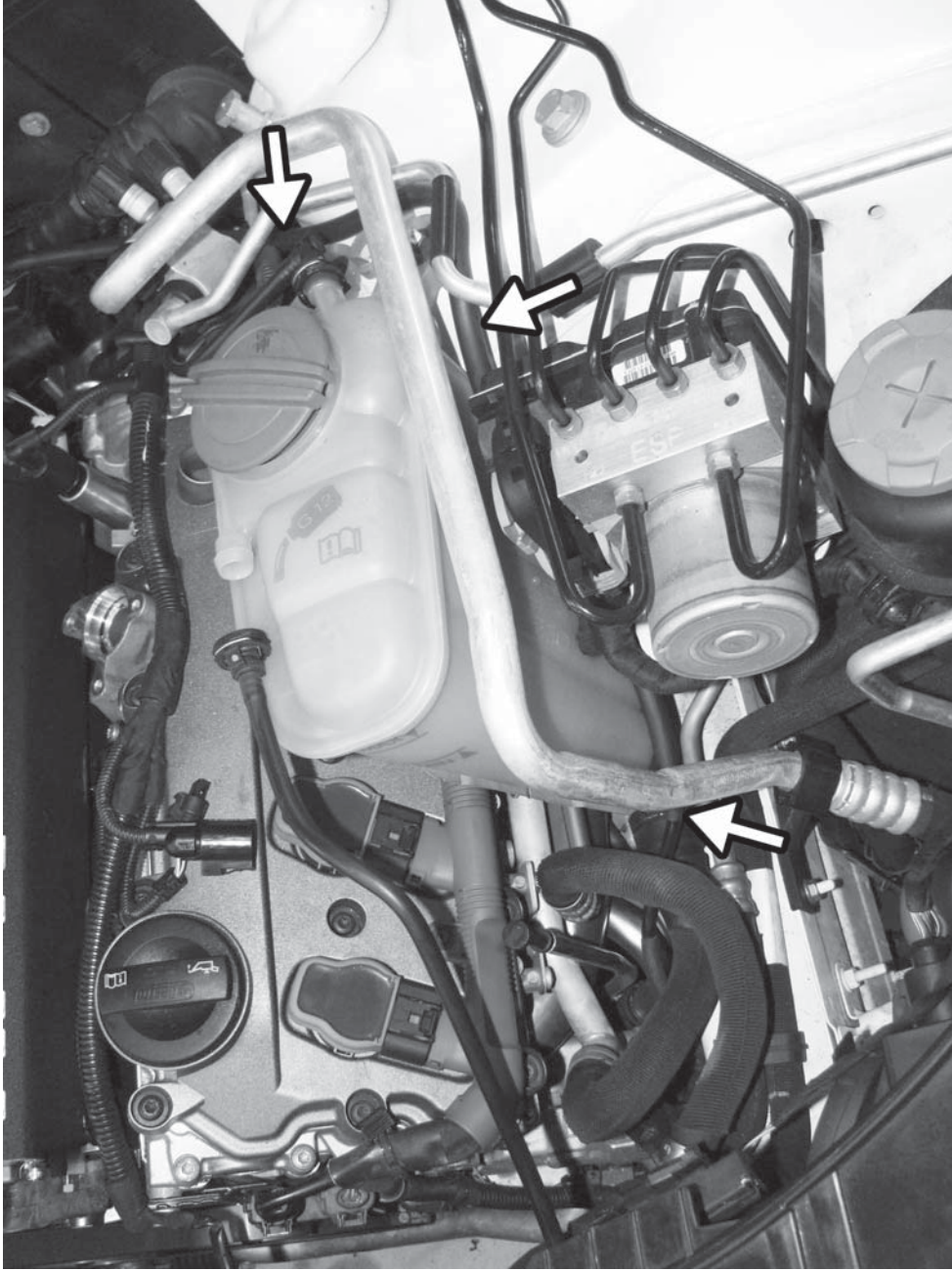

98) Remove the factory plastic line that runs to the leak detection pump by disconnecting it from the rubber junction behind the airbox. Leave the short rubber junction in place.



99) Install a supplied "T" fitting into the rubber junction to the leak detection pump. Connect the line from the vacuum canister to one side of the "T".

On the bottom side of the "T", connect a short piece of hose to the supplied stepped barb fitting, and connect the vacuum line from the front of the airbox.

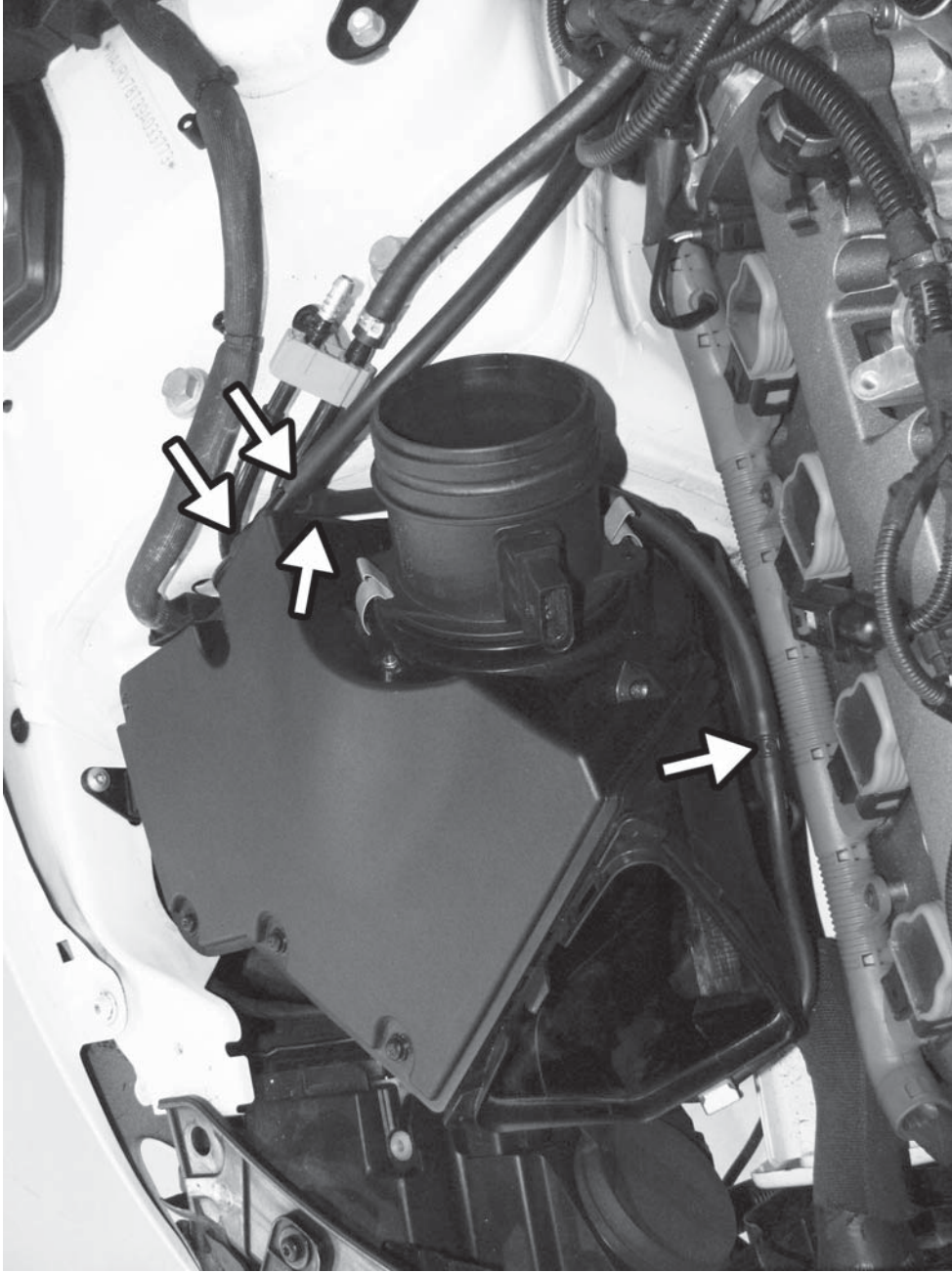

100) From the previously removed vacuum system, remove the check valve.

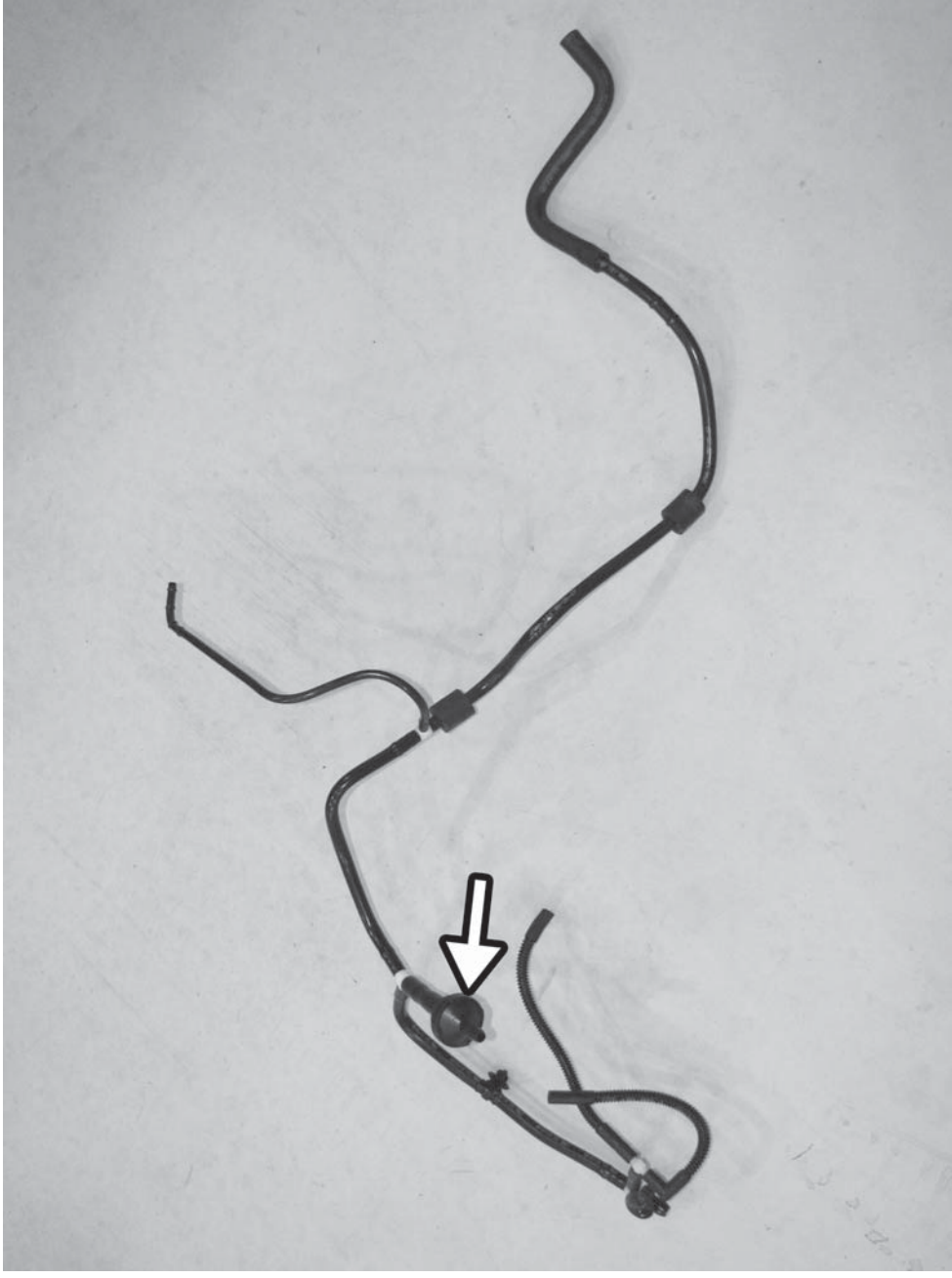

101) Install the check valve with a short piece of vacuum line to the upper left barb coming out of the supercharger inlet.

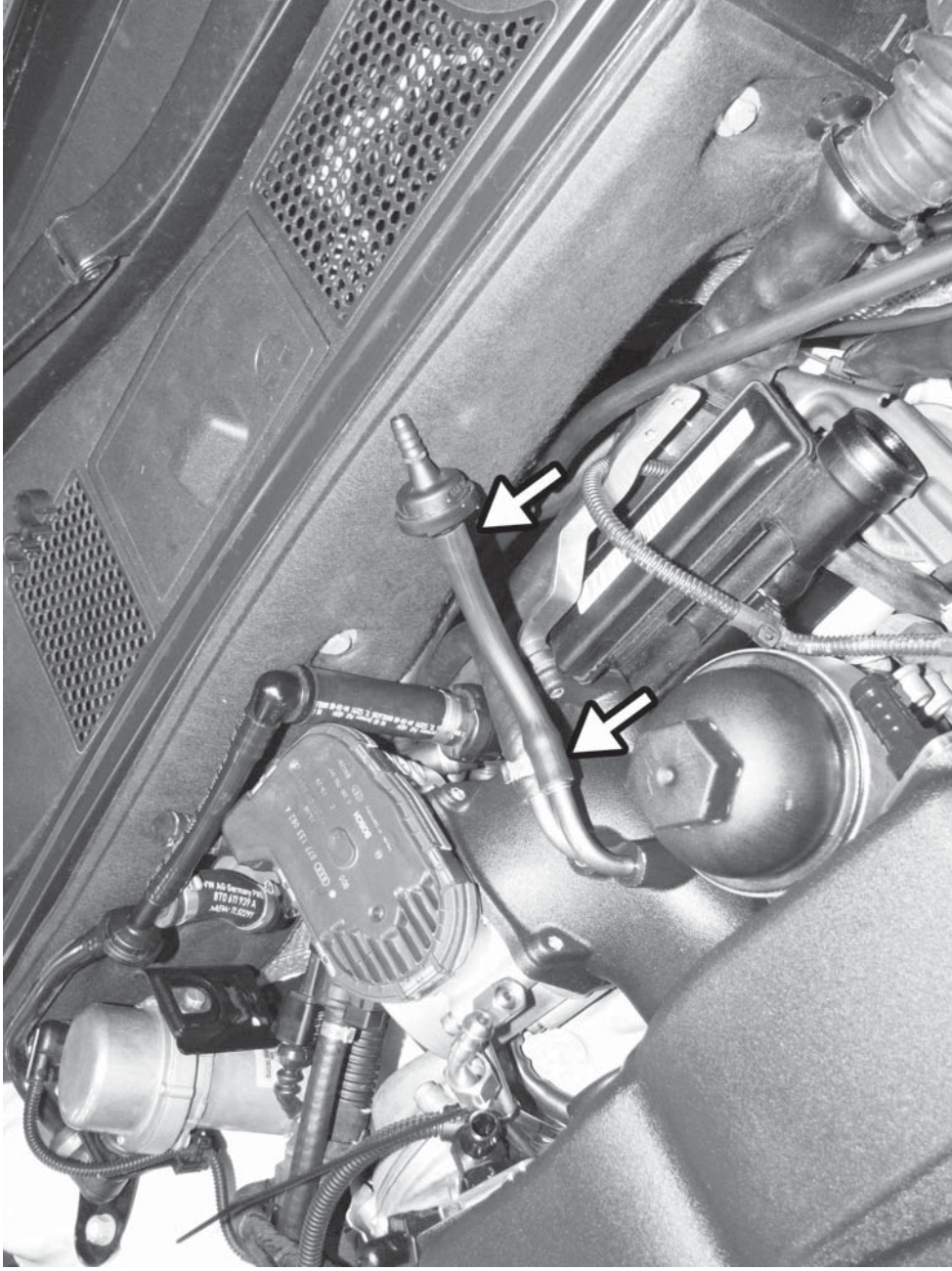

102) Cut the previously routed vacuum line behind the engine approximately behind the check valve just installed. Install a "T" in the line and connect the check valve to the "T" with a short piece of hose, as shown. When completed, tuck this line back behind the engine.

* - Some vehicles are equipped with a solenoid valve on the left cylinder head. If so, install an additional "T" in the rear vacuum line with a short section of hose. Then install a vacuum line reducer and another short section of hose, connecting the hose to the rear of the solenoid valve.

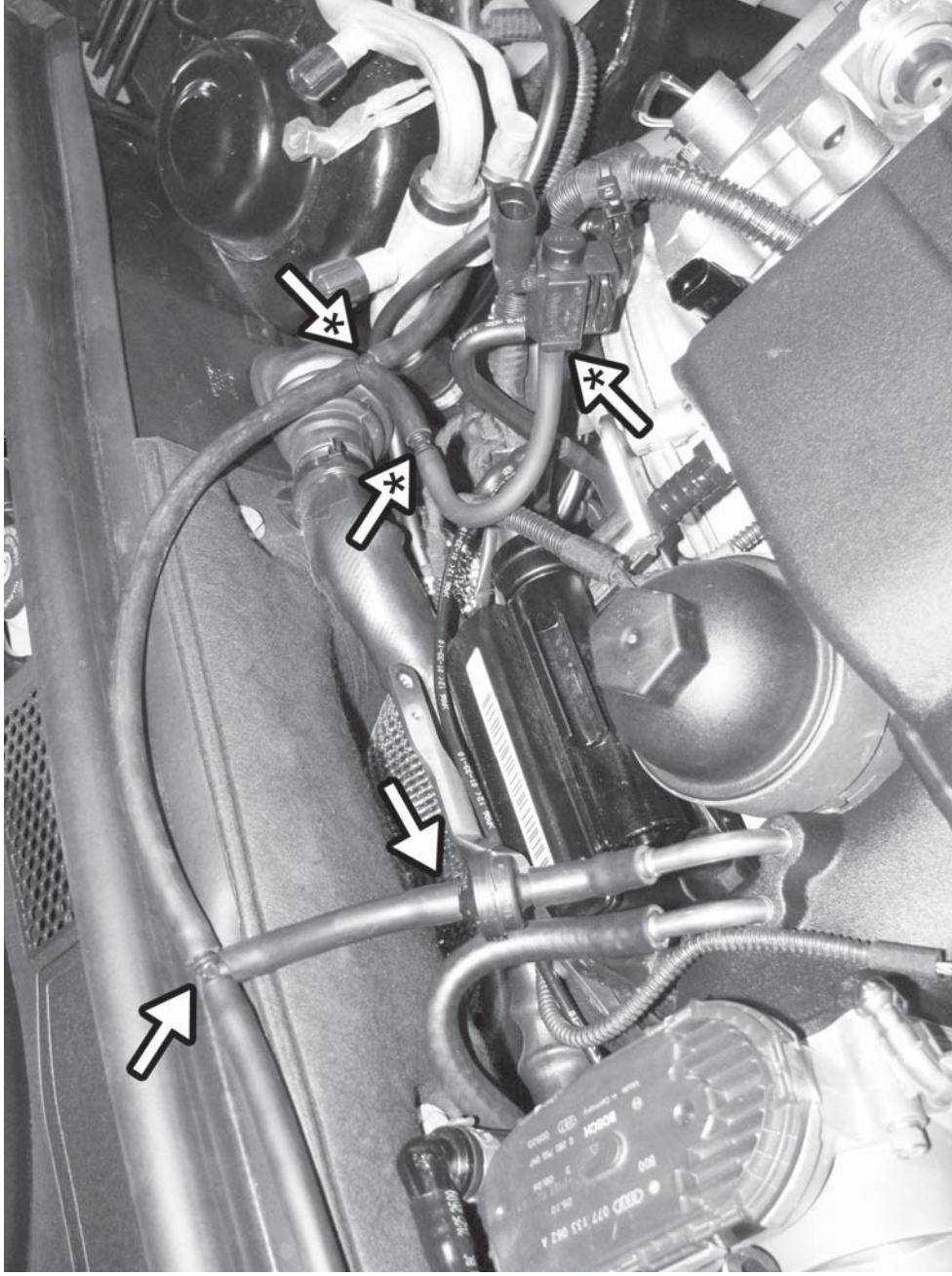

103) Reinstall the factory high pressure fuel pumps. Connect the electrical connectors and torque the six screws to 9Nm.

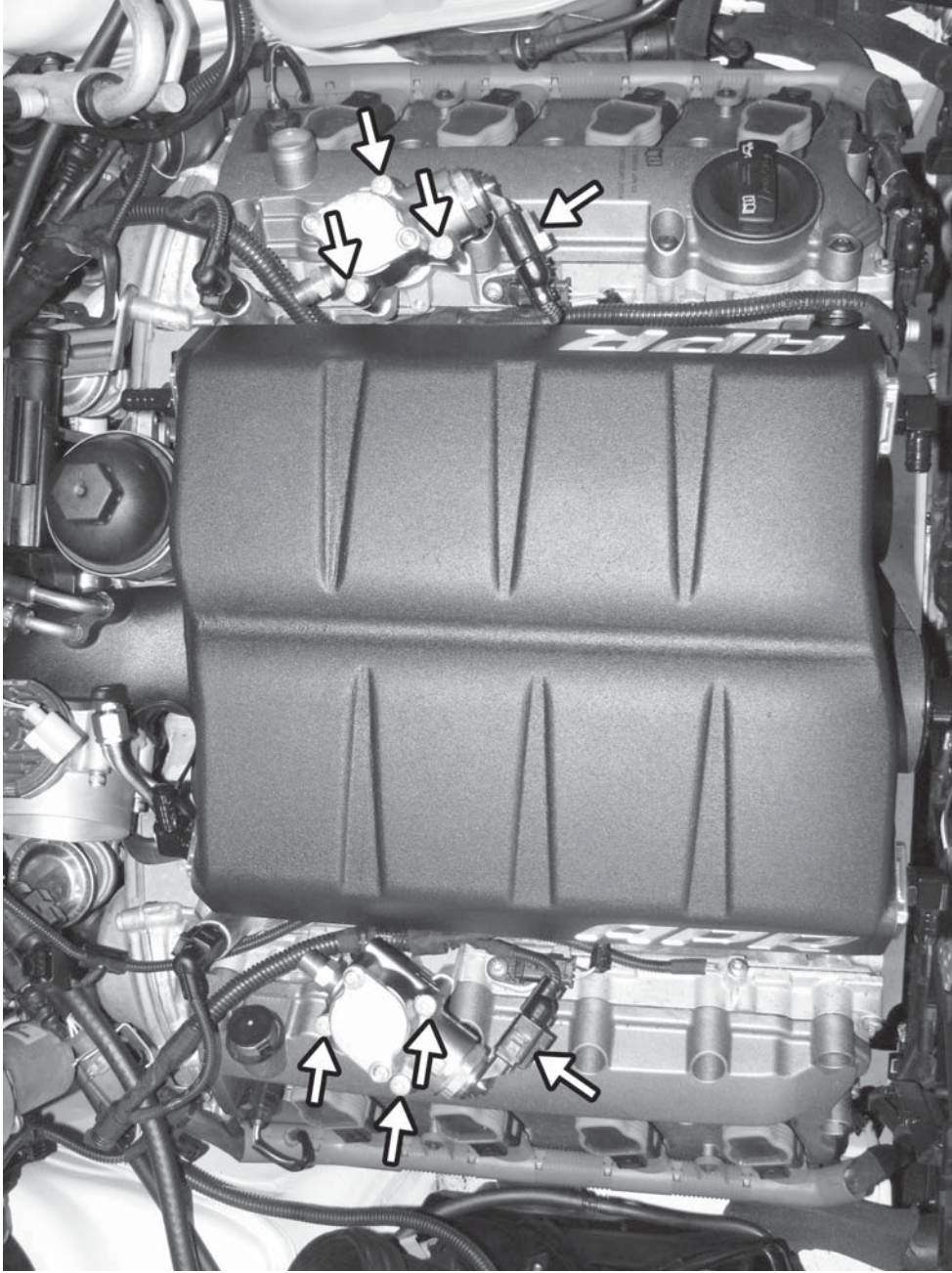

104) After ensuring the OEM flat crush washer has been removed, install the conical APR crush washers with the peak of the cone facing away from the pump.

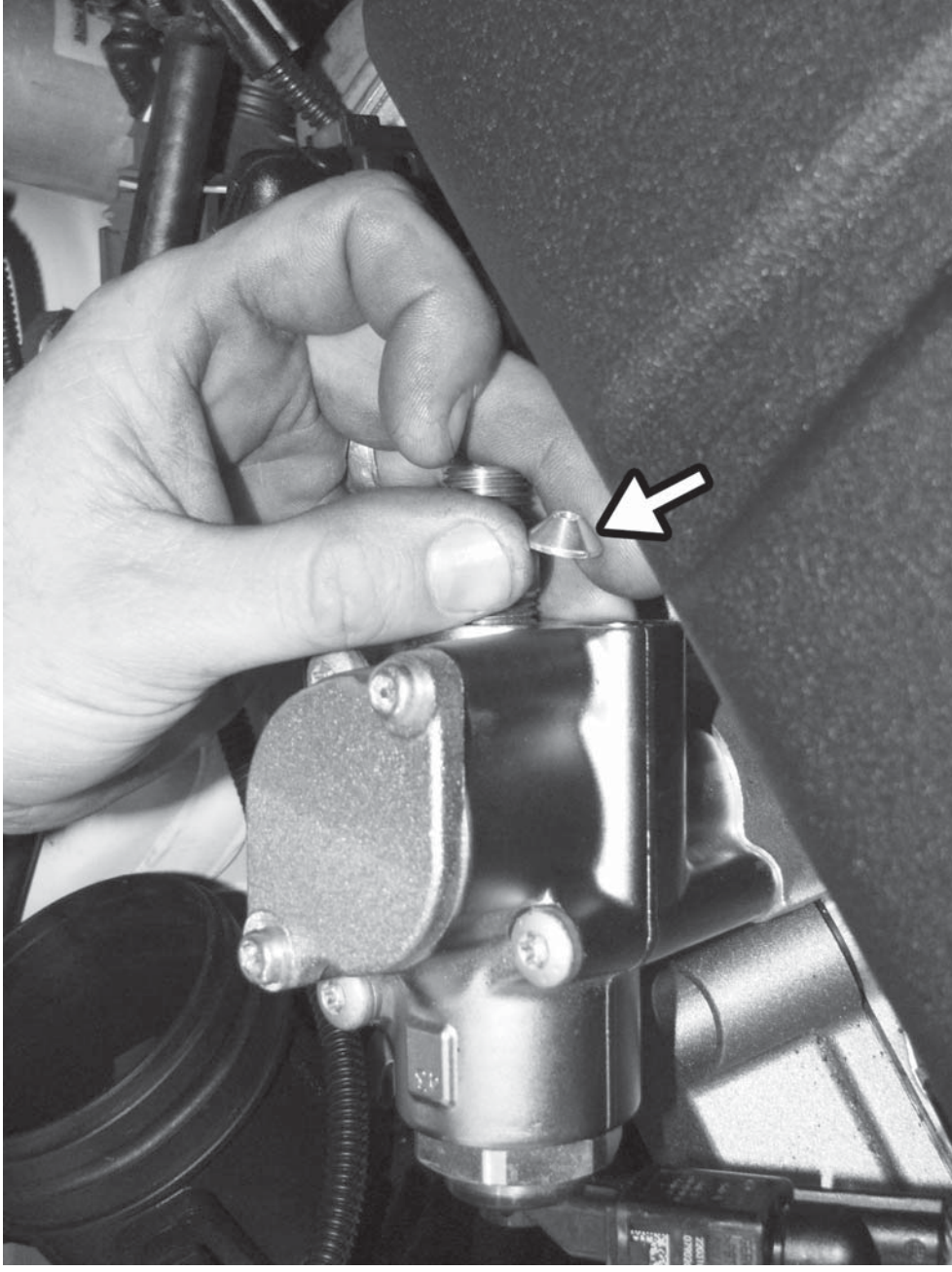

105) Loosely install the supplied bracket on the APR fuel distribution assembly with the supplied 5mm allen screws and lockwashers.

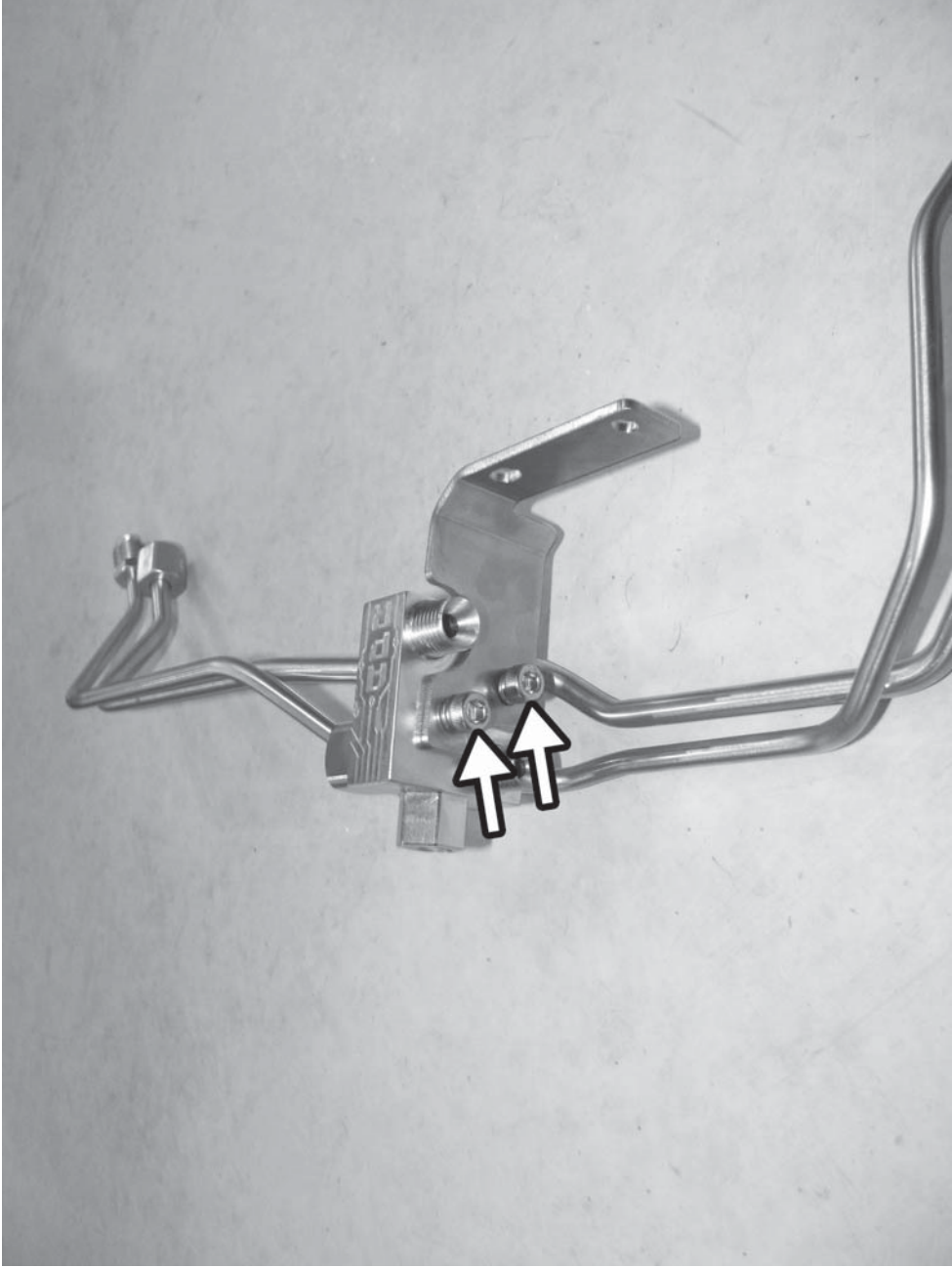

106) Install the APR fuel distribution assembly. It may be necessary to carefully manipulate the OEM lines from under the supercharger to connect directly to the APR fuel distribution block.

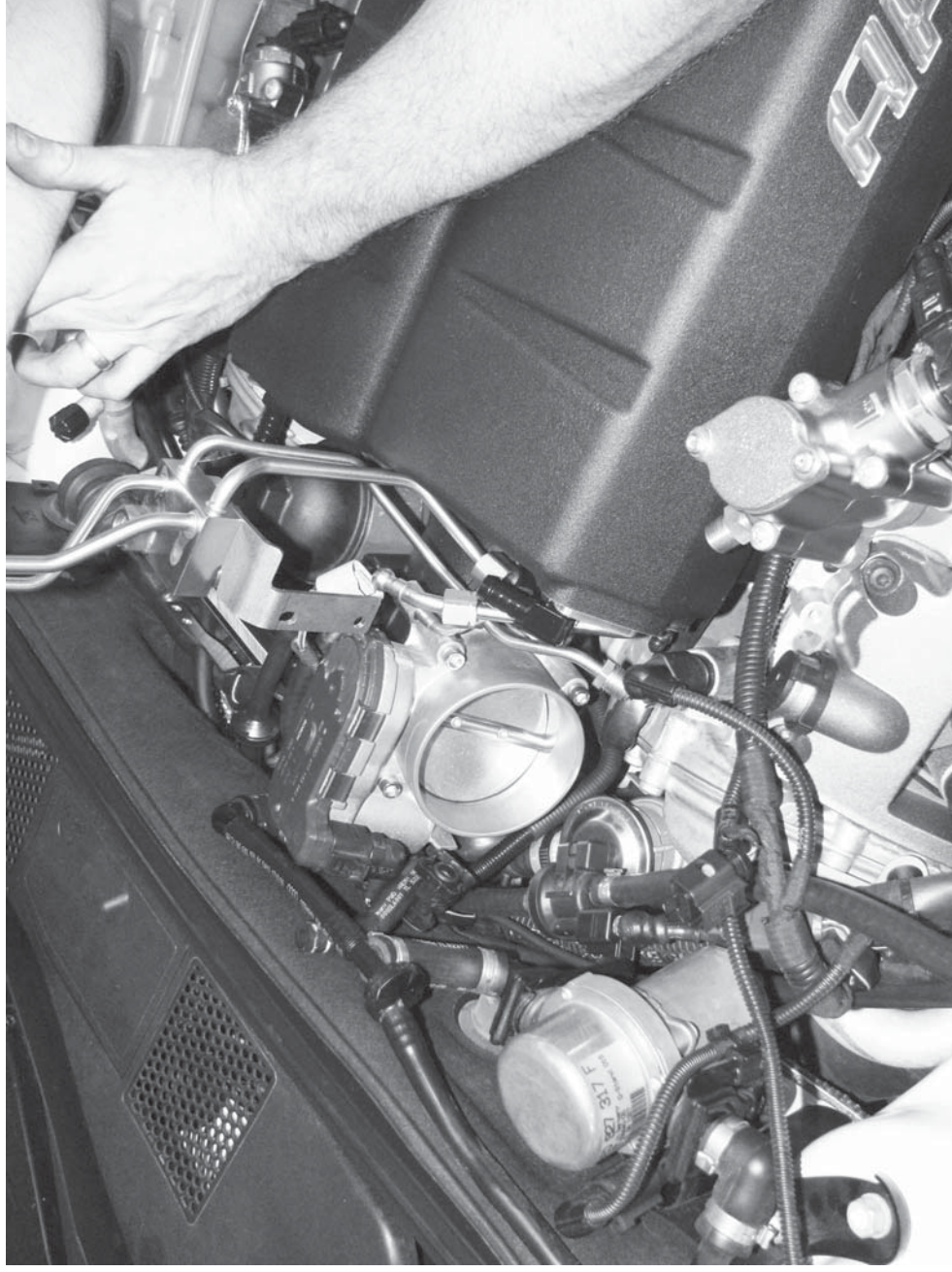

107) Loosely connect and start all six fittings to and from the APR fuel distribution assembly. All fittings should line up and easily start.

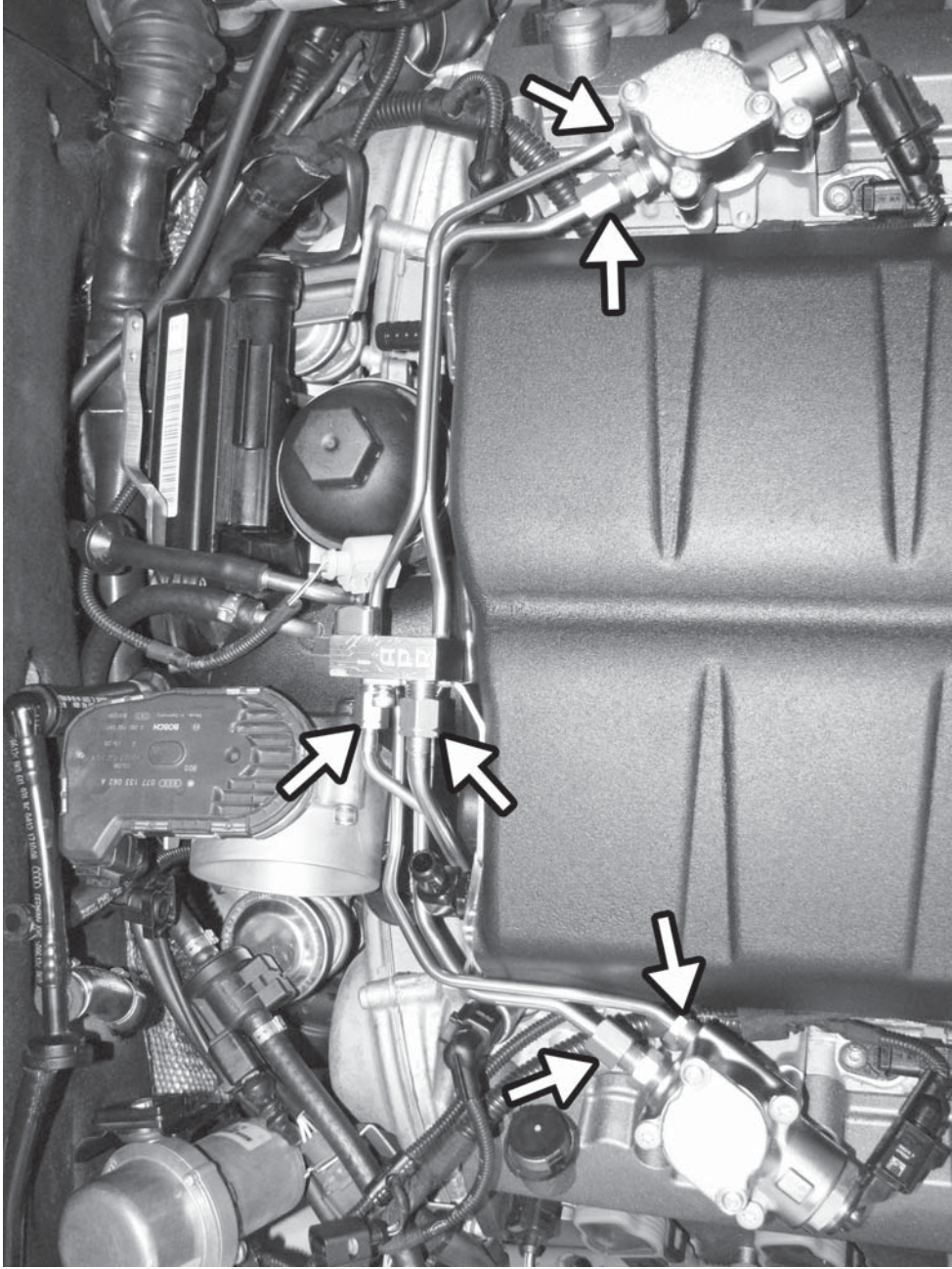

108) Install the two 5mm allen screws to connect the fuel distribution assembly bracket to the supercharger. Tighten all four screws on the bracket.

Tighten all fuel line connections. Counter hold all fittings to prevent tweaking the lines.

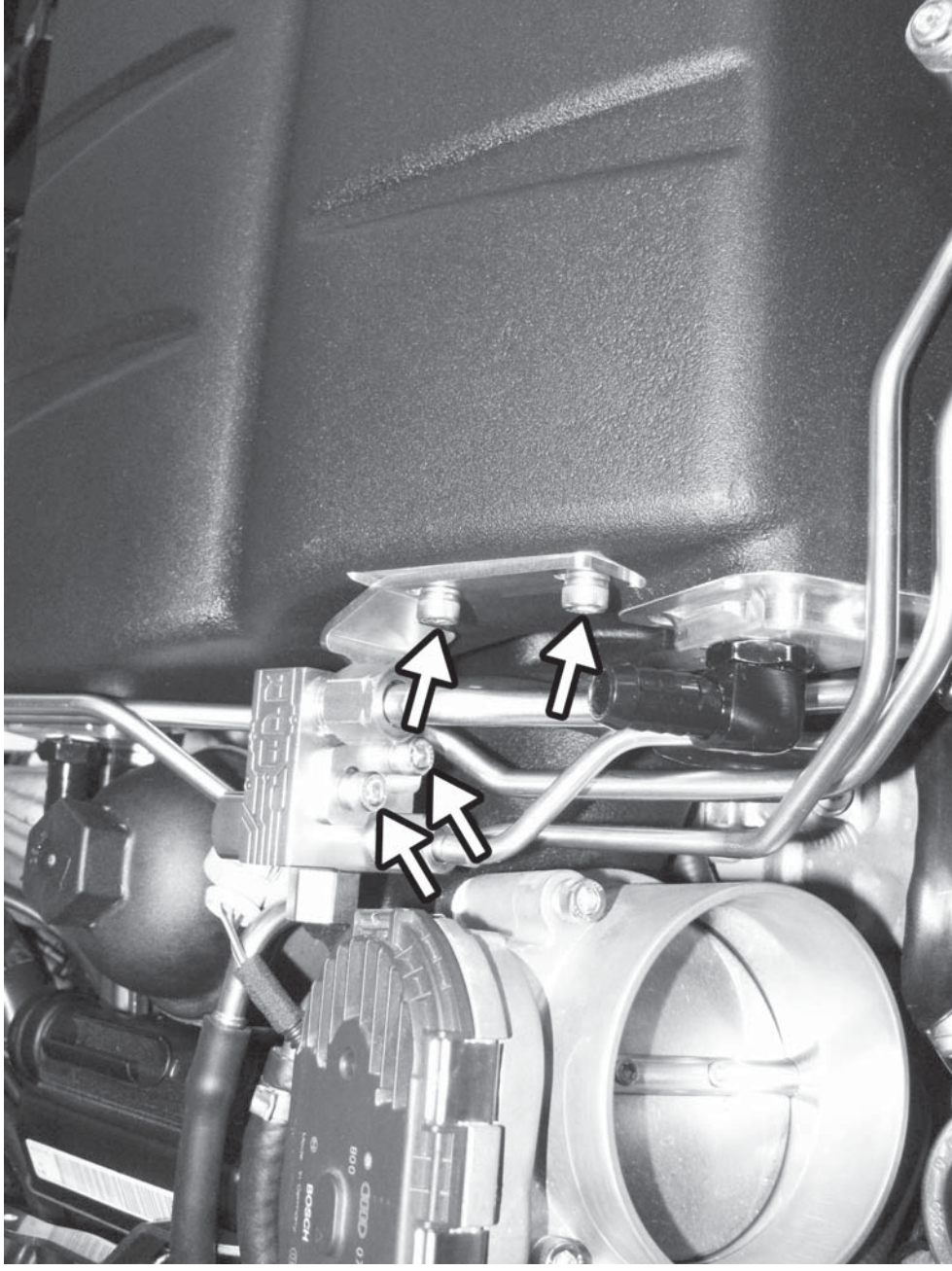

109) Install the stock low pressure fuel sensor with a 24mm wrench into the back of the APR fuel distribution assembly. Reconnect the electrical connector to the fuel pressure sensor.

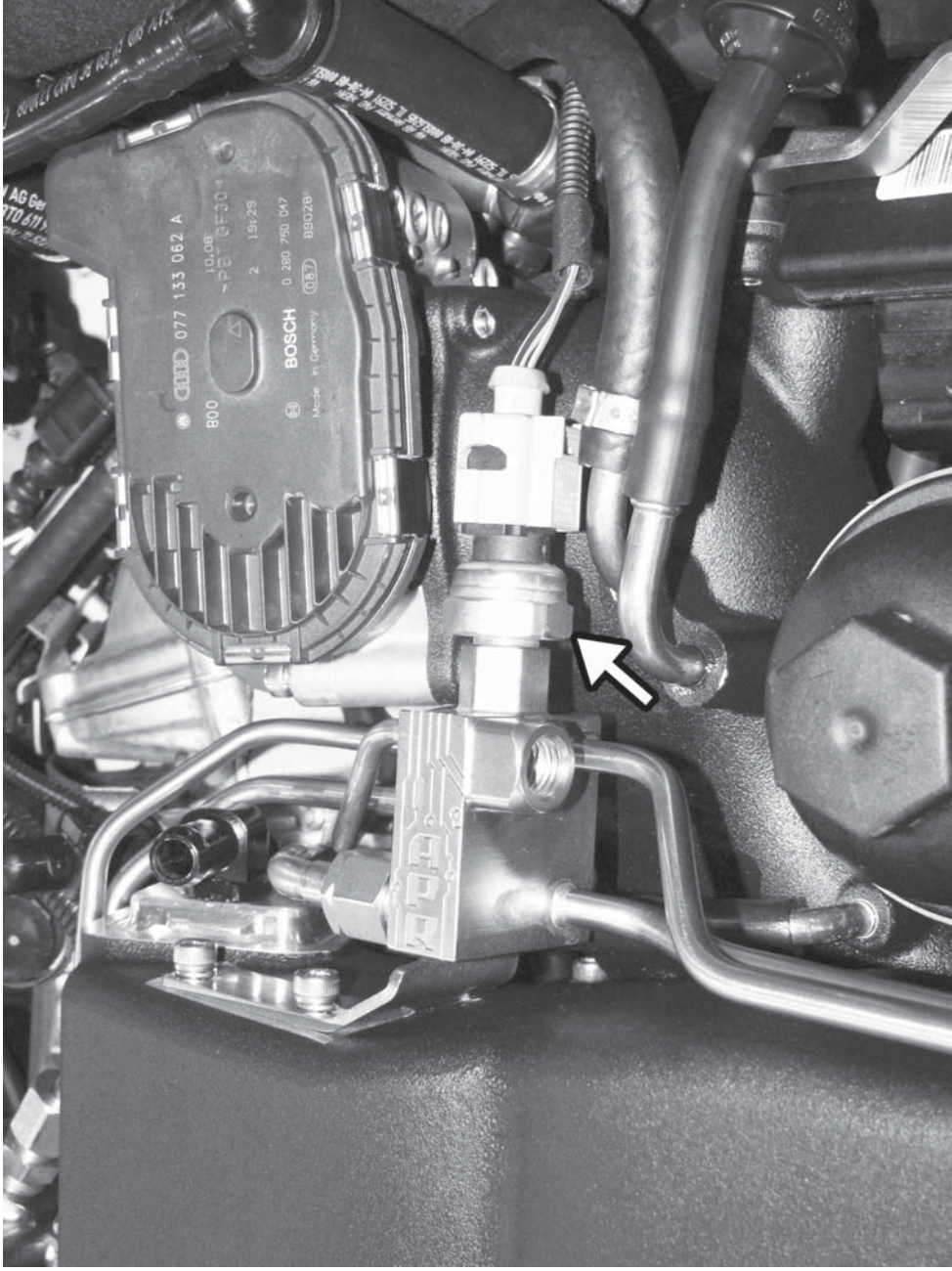

110) Connect the supplied fuel hose to the metal pipe on the right shock tower with a clamp. Route the hose behind the throttle body, and on the other end of the hose, install the barbed banjo fitting with a clamp.

Connect the banjo fitting with the banjo bolt and crush washers to the APR fuel distribution assembly.

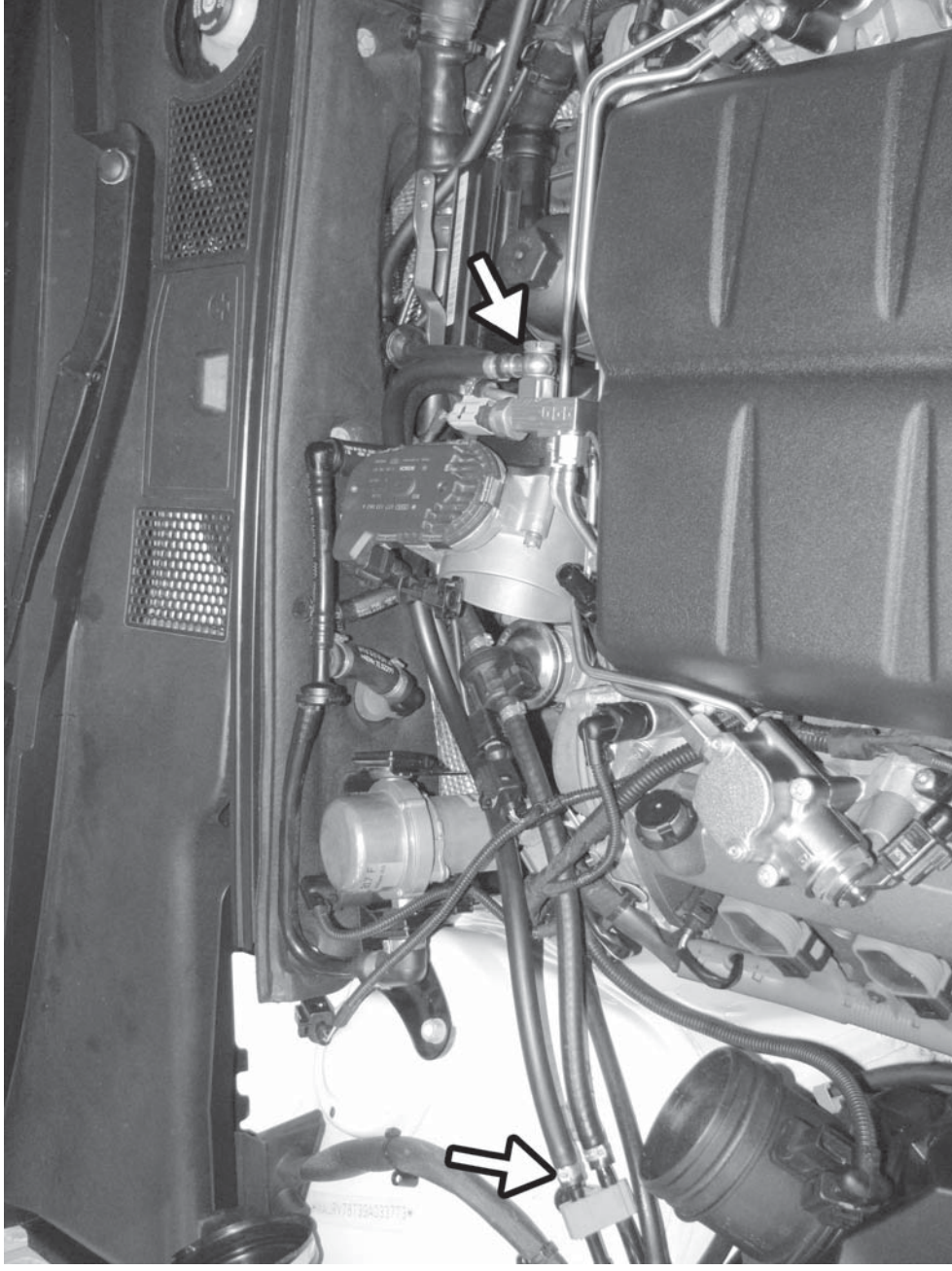

111) Install the APR coolant reservoir on the bracket behind the oil separator with the two 4mm allen screws and lockwashers.

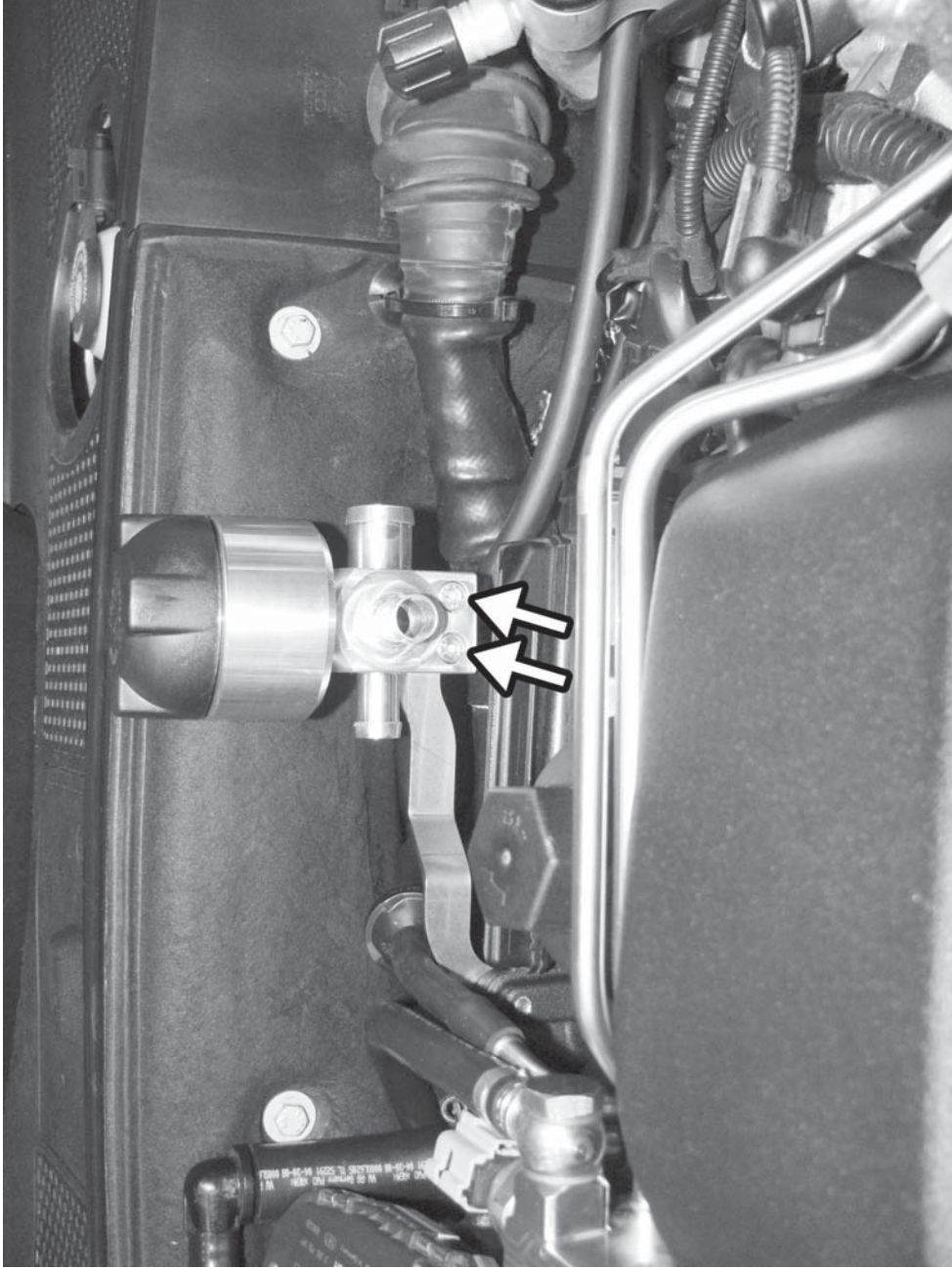

112) Install the two shortest, smaller wrapped coolant hoses between the coolant reservoir and the supercharger and secure with the supplied clamps.

It may be necessary to reclock the right rear coolant fitting on the supercharger in order for the hose to fit correctly. Use the supplied wrench for this purpose.

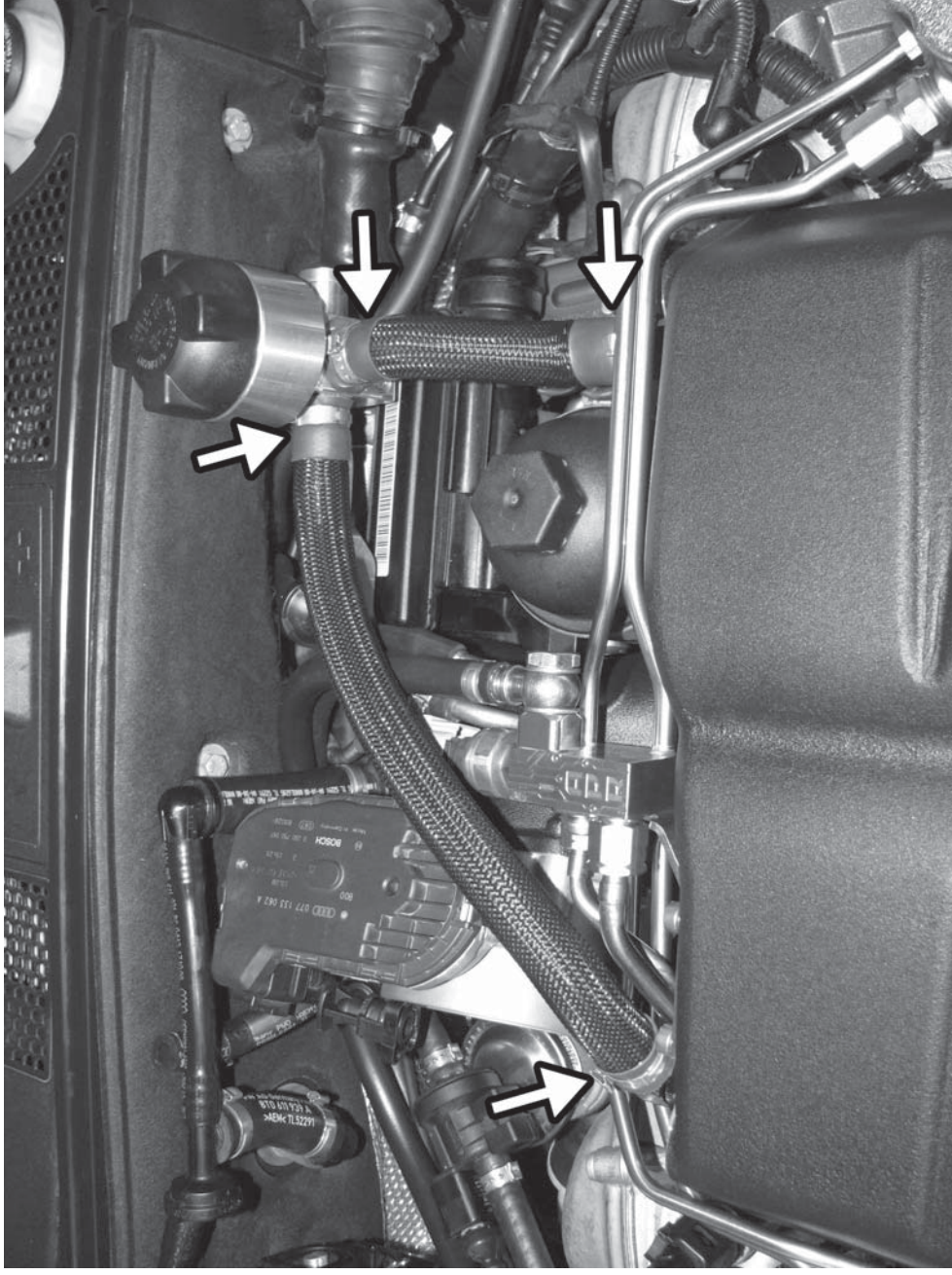

113) Install the APR radiator mounting brackets on the APR radiator with the four (two on either side) 6mm allen screws.

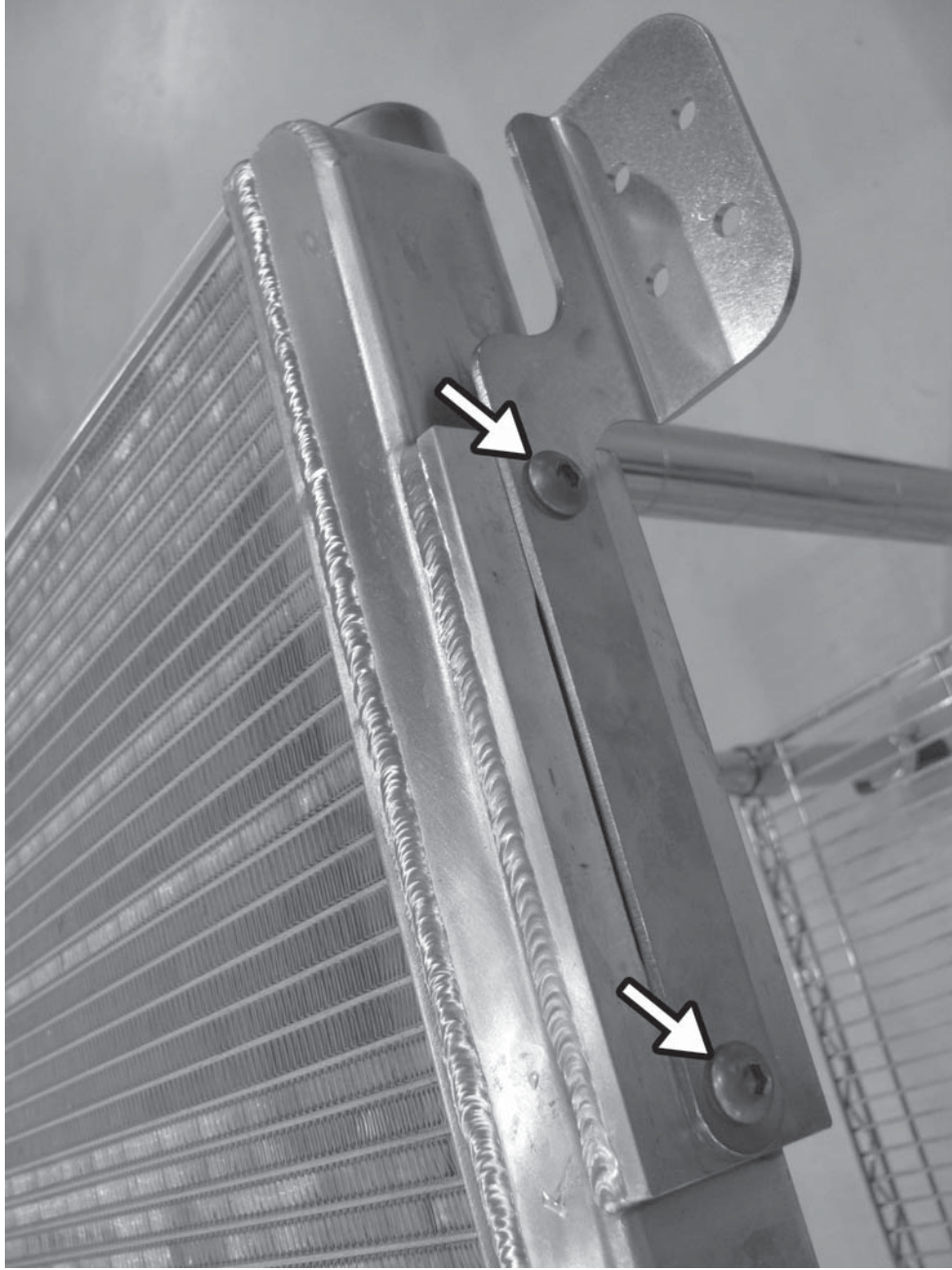

114) Set the APR radiator in the center of the back side of the bumper beam and mark the four screw locations from the radiator brackets. Once marked, you can set the bumper beam on the car to confirm the APR radiator will sit in the correct place in front of the A/C condenser.

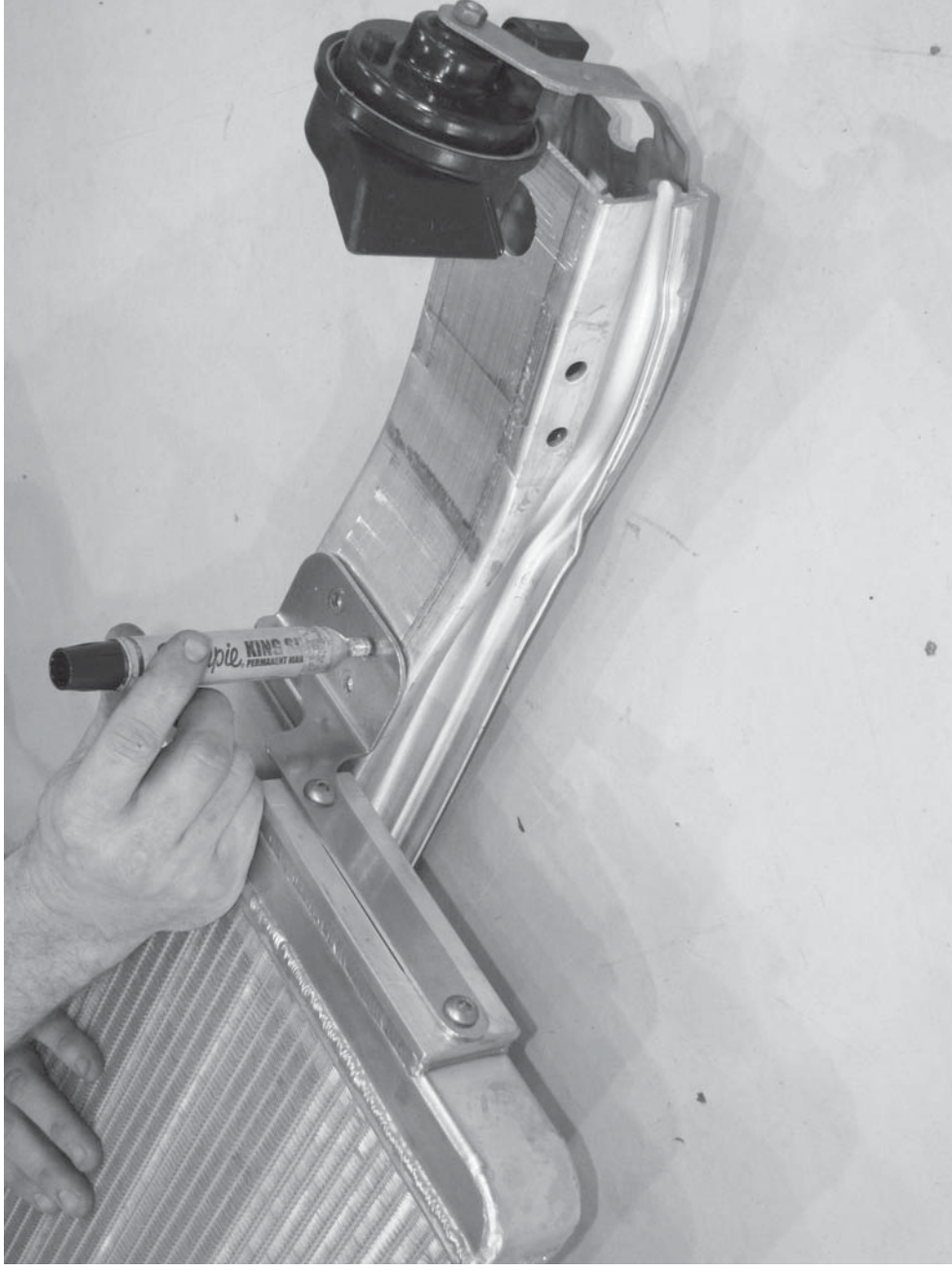

114) Once the radiator mounting location is verified, predrill the holes with the included drill bit. Install and tighten the eight (four on each side) 10mm self tapping screws.

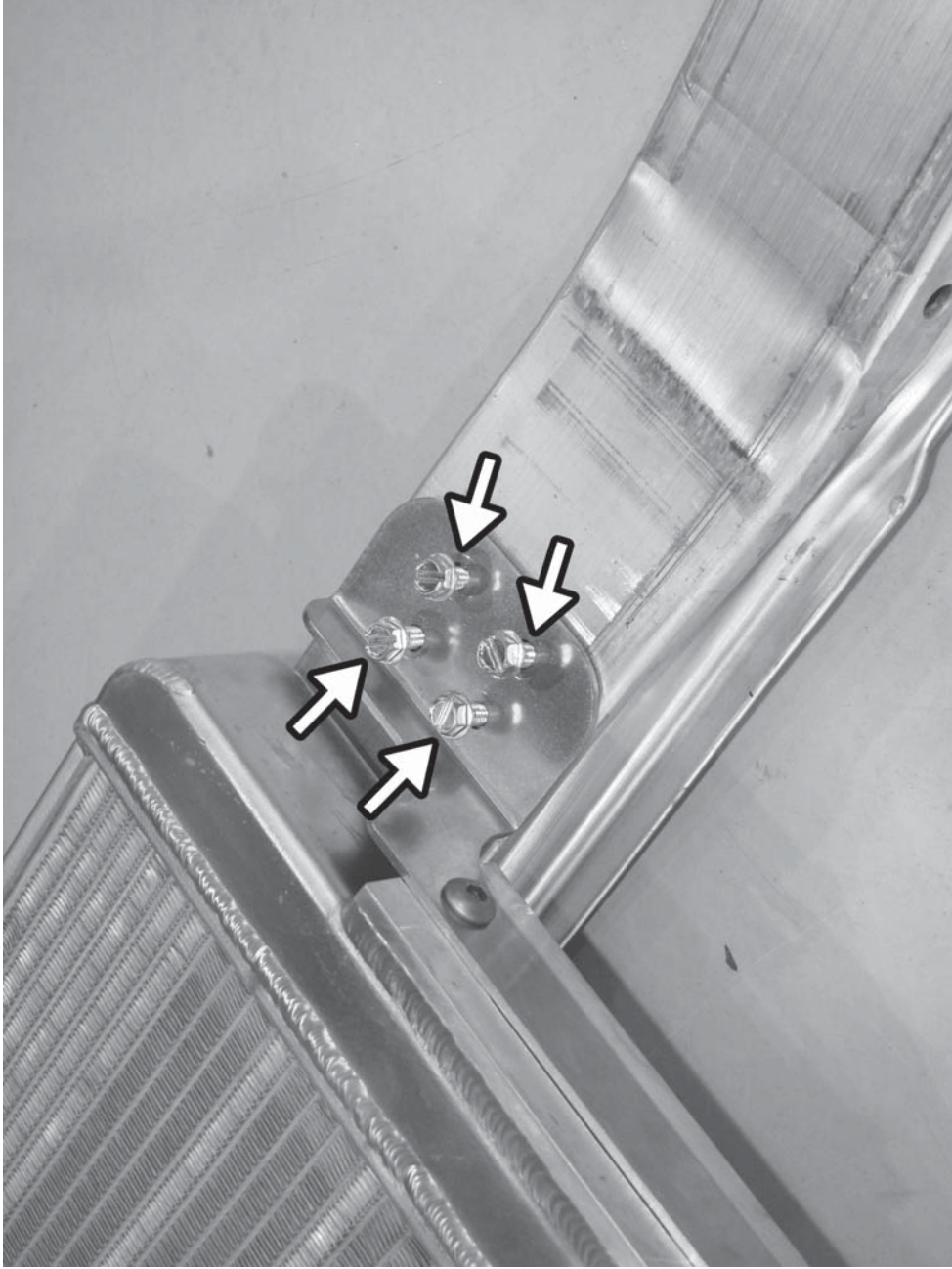

115) Remount the bumper beam with the APR radiator attached to the core support with the original 13mm screws.

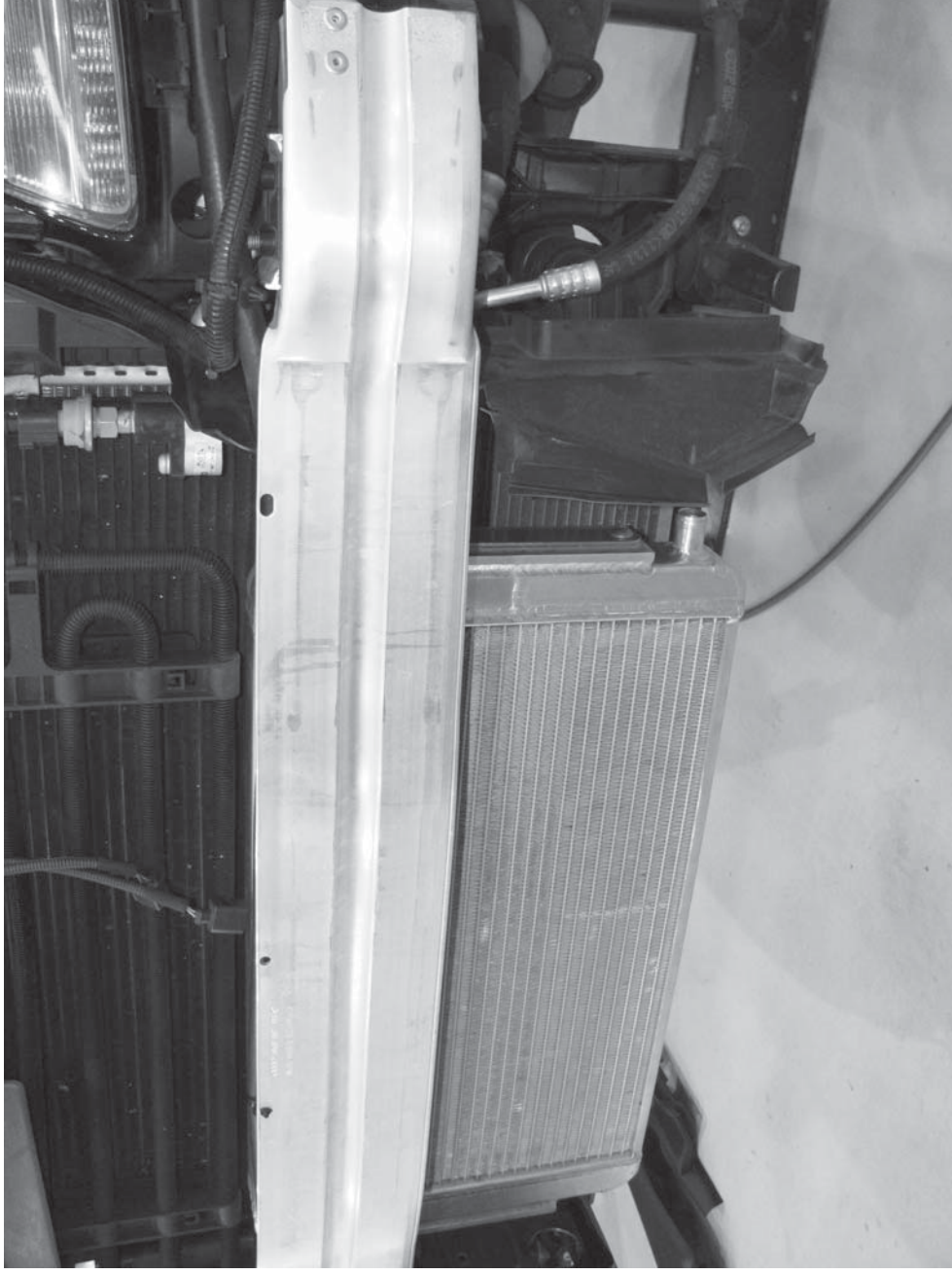

116) Install the longest, larger wrapped coolant hose to the left port on the coolant reservoir and secure with a clamp. Route the line under the A/C lines, alongside the engine, and down behind the left headlight.

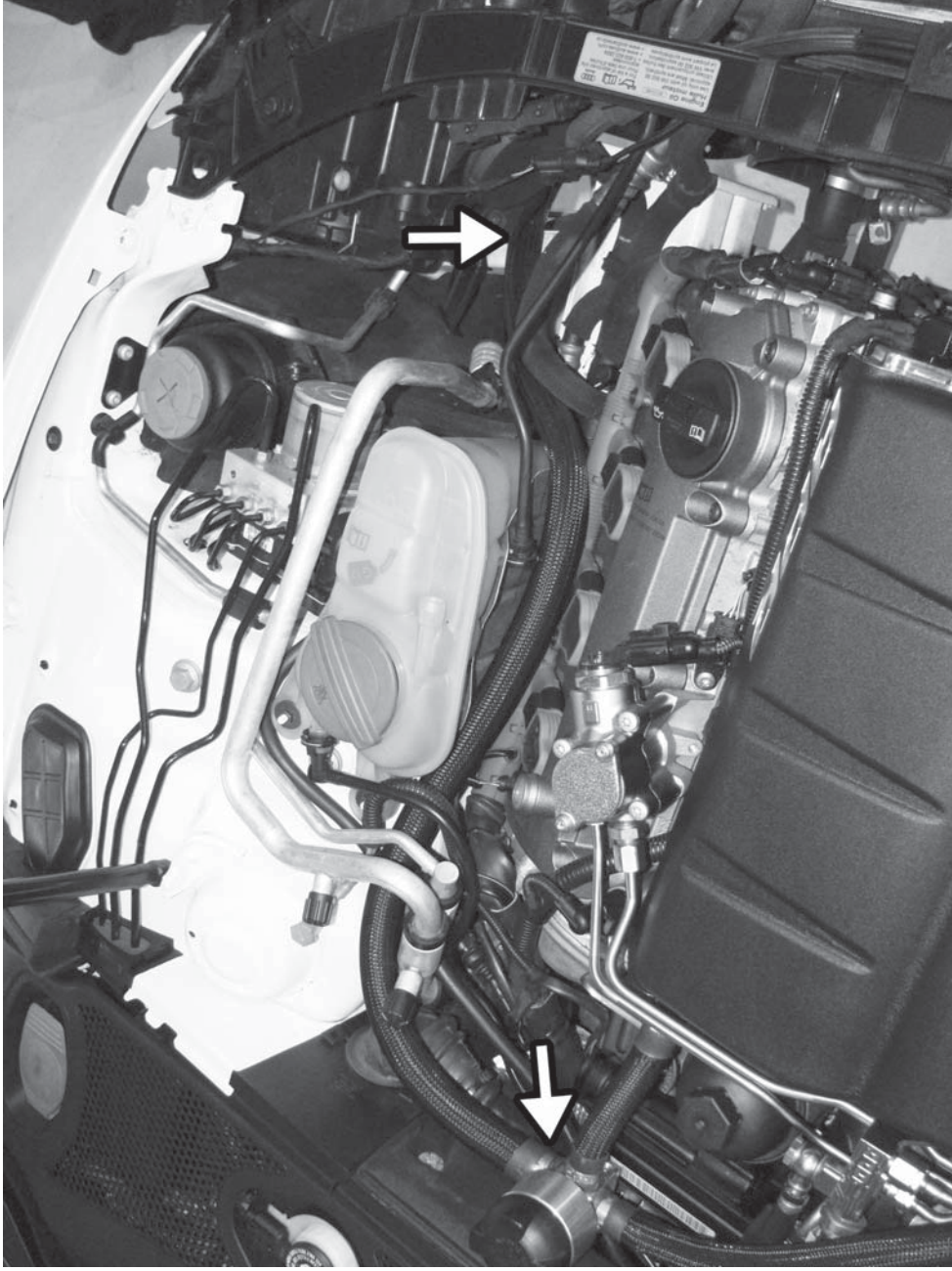

117) Using a hole saw larger than the outside diameter of the large coolant hose, cut an opening in the radiator air ducts for the hose.

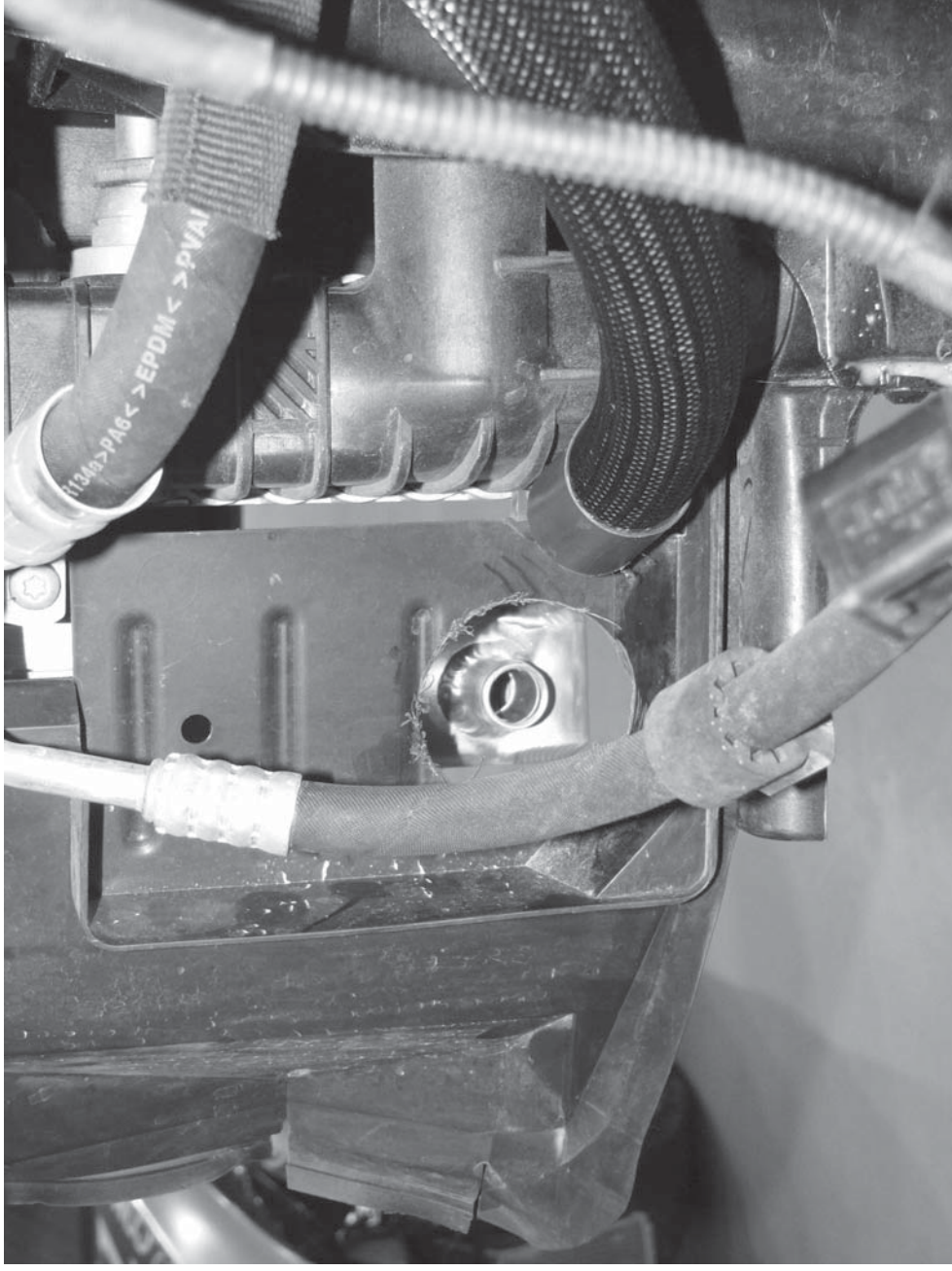

118) Pull the coolant hose through the hole in the air duct, and connect to the left side of the APR radiator.

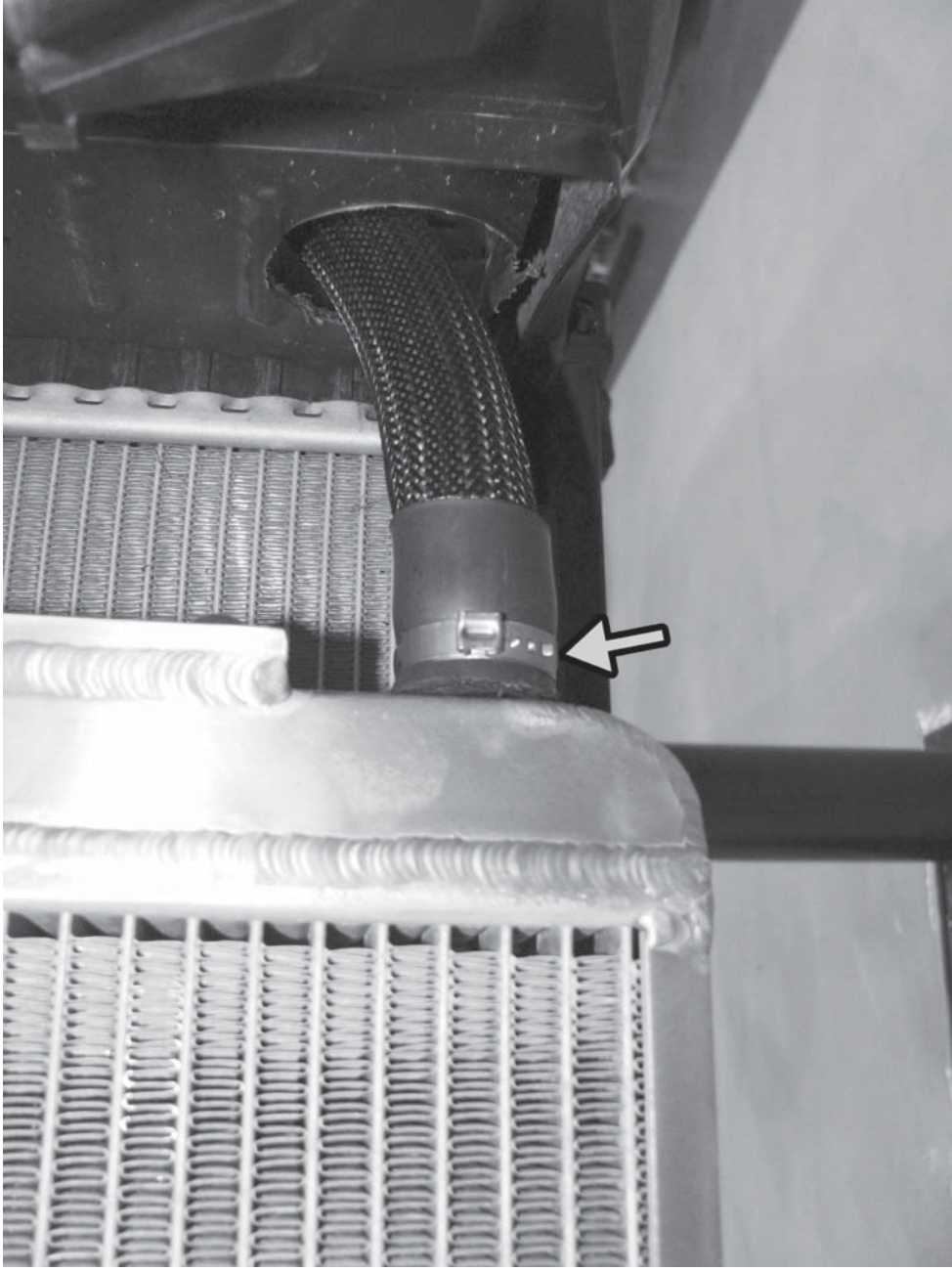

119) Assemble the "Y" connection with the two longer, small wrapped coolant hoses and the one molded coolant hose and secure with clamps, as shown.

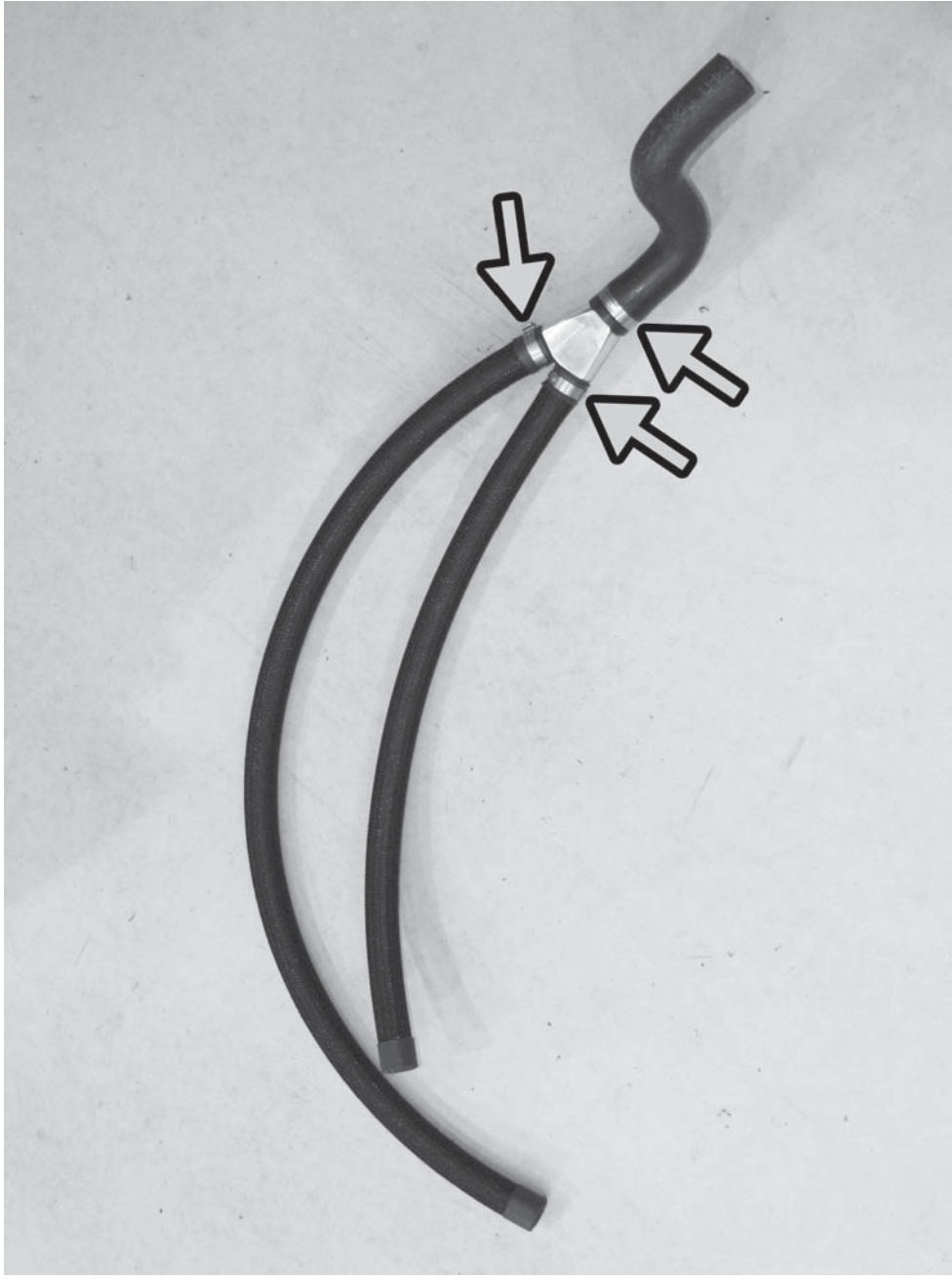

120) After putting the supplied threadlocker on three of the four 5mm allen screws and washers, attach the APR pump to the supplied bracket as shown. Tighten the screws just enough to make the rubber bushings between the pump and bracket deform.

Leave the fourth screw and washer aside to be installed later.

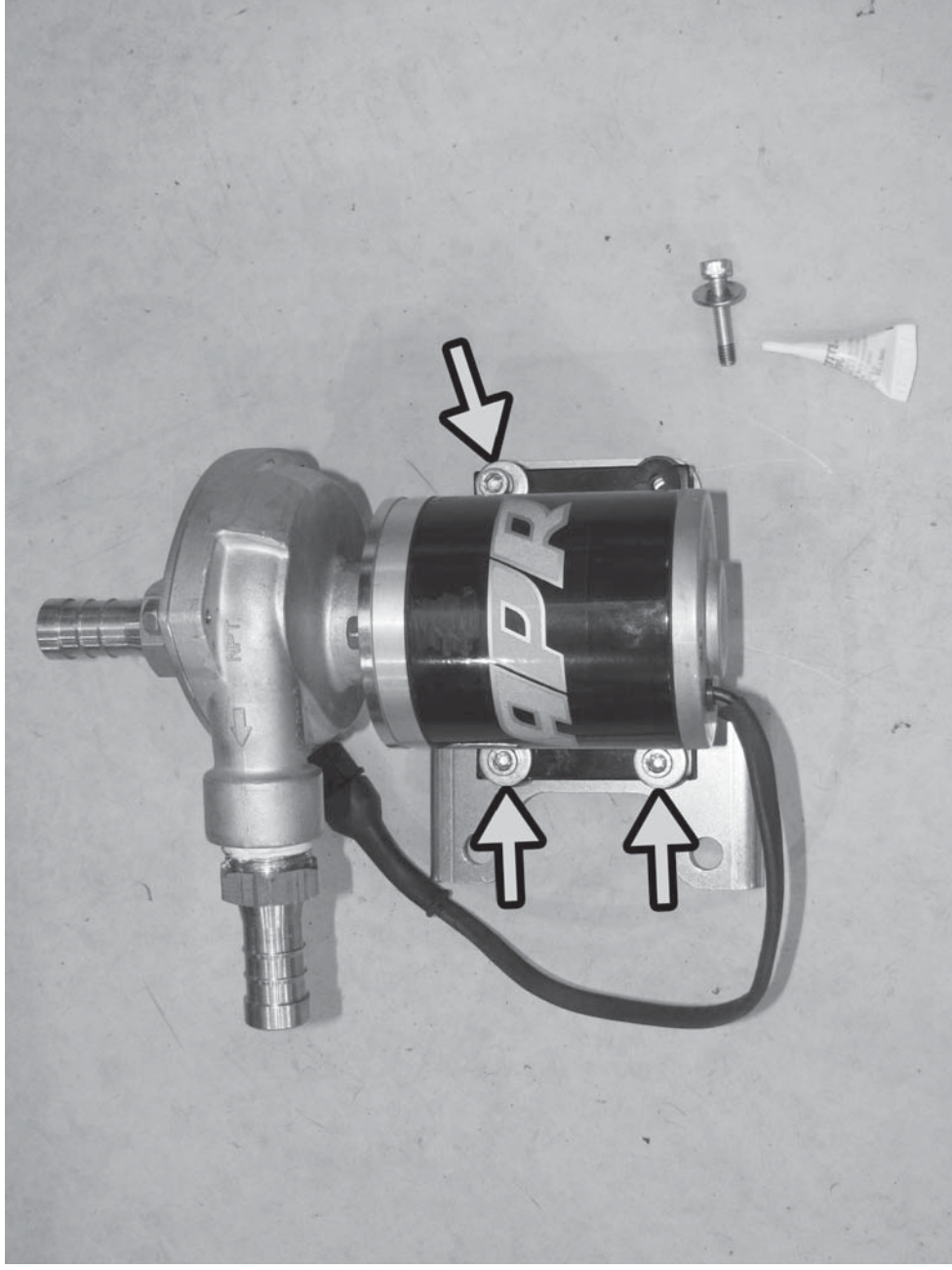

121) On the back of the radiator core support, disconnect the lower fan harness. Install the APR Jumper harness inline with the factory harness.

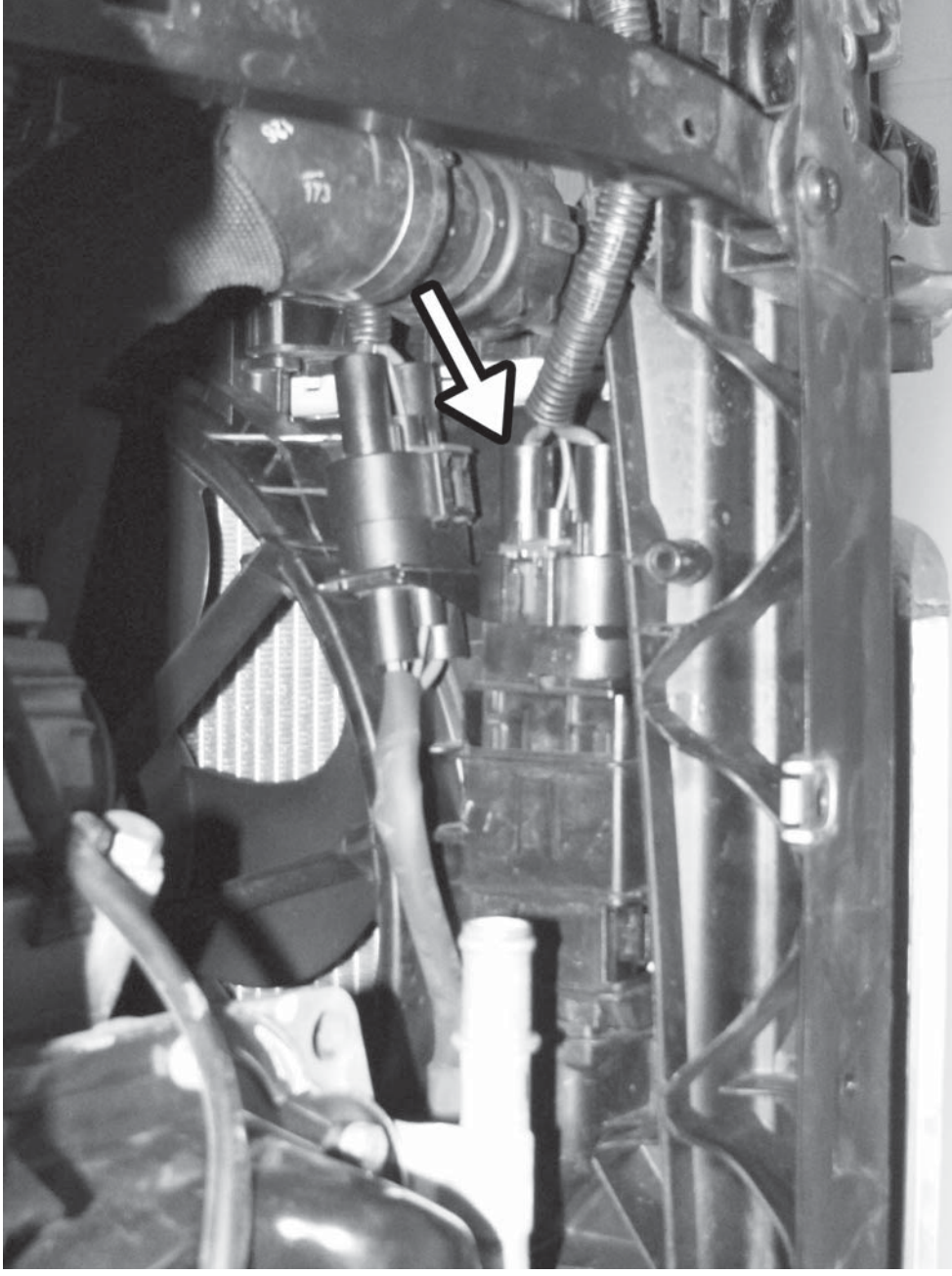

122) Carefully push the radiator core support back in its normal location. On the right side, remove the long screw used to hold the core support and install the two long 17mm bolts and washers in the lower holes. Install the factory bolt in the remaining upper hole. On the left side, remove the long screw and replace with the three stock core support screws.

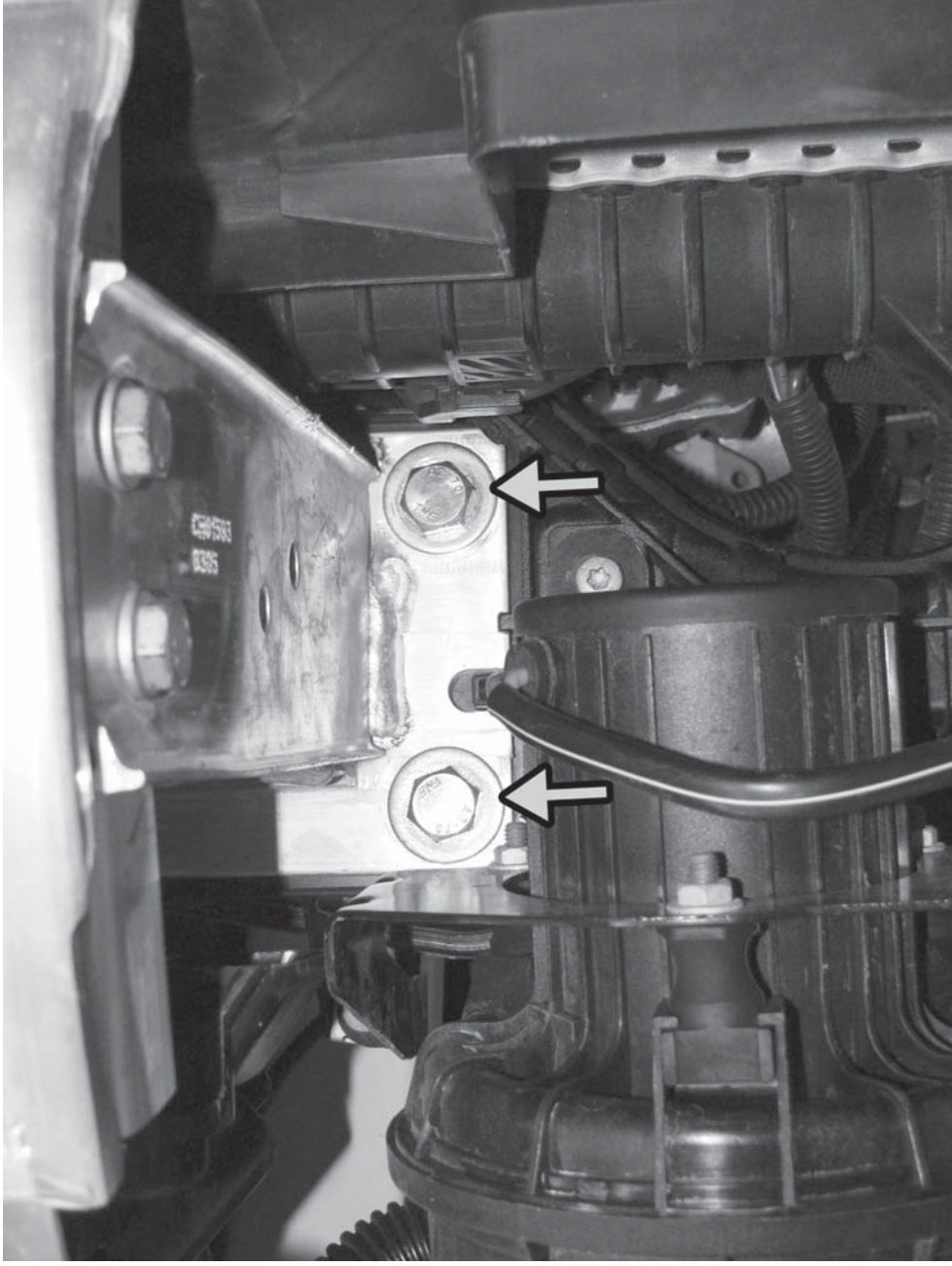

123) From under the right frame rail under the core support, remove the plastic clip holding the wiring harness in place.

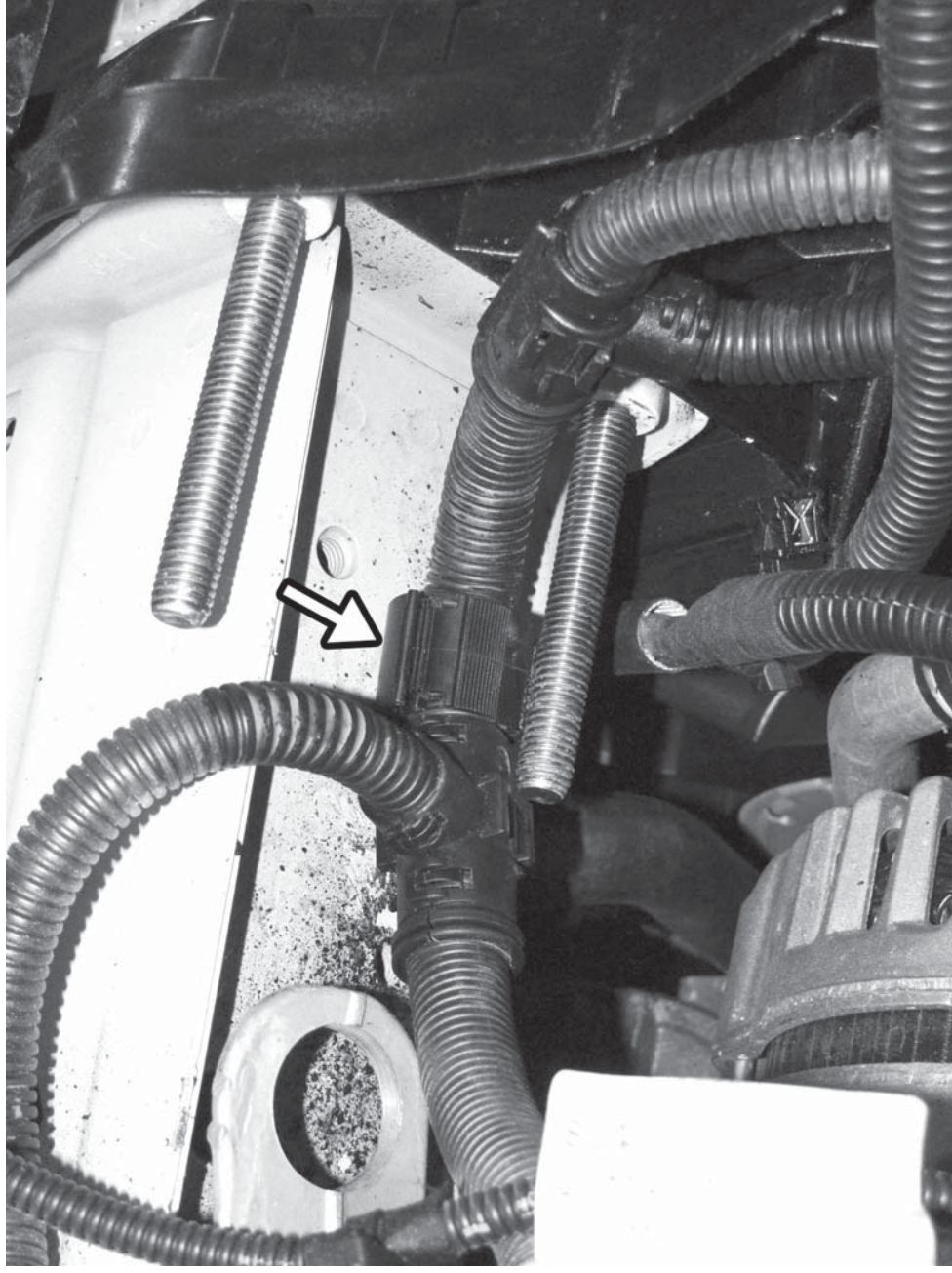

124) Slide the supplied spacers over the long APR core support bolts and then mount the APR pump as shown. Secure with the supplied lockwashers and 17mm nuts.

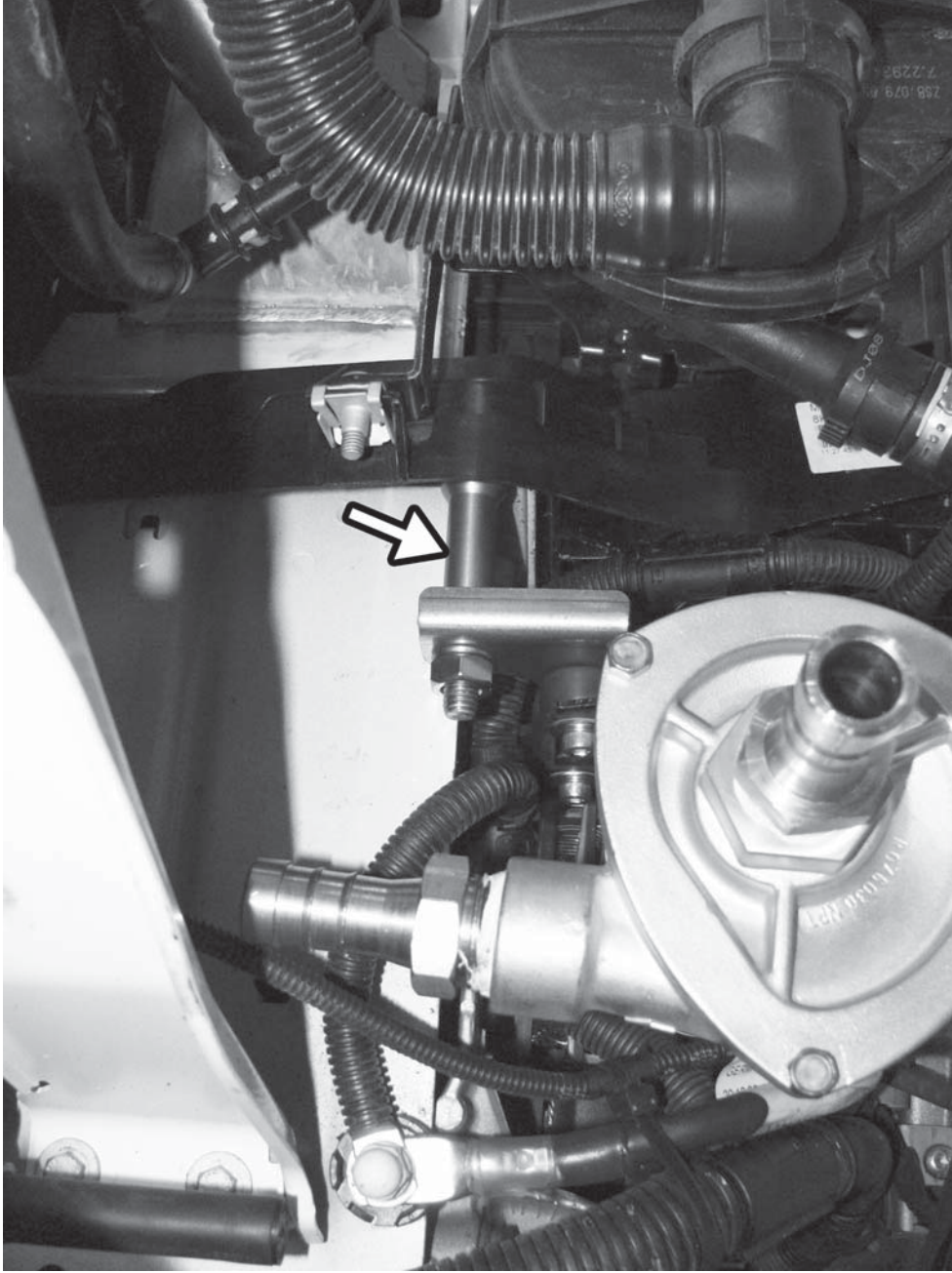

125) Connect the two pin connector to the APR coolant pump, and route the excess harness out of the way and secure it with cable ties.

Mount the relay on the APR pump bracket using the fourth bolt on the bracket with threadlocker to secure it in place.

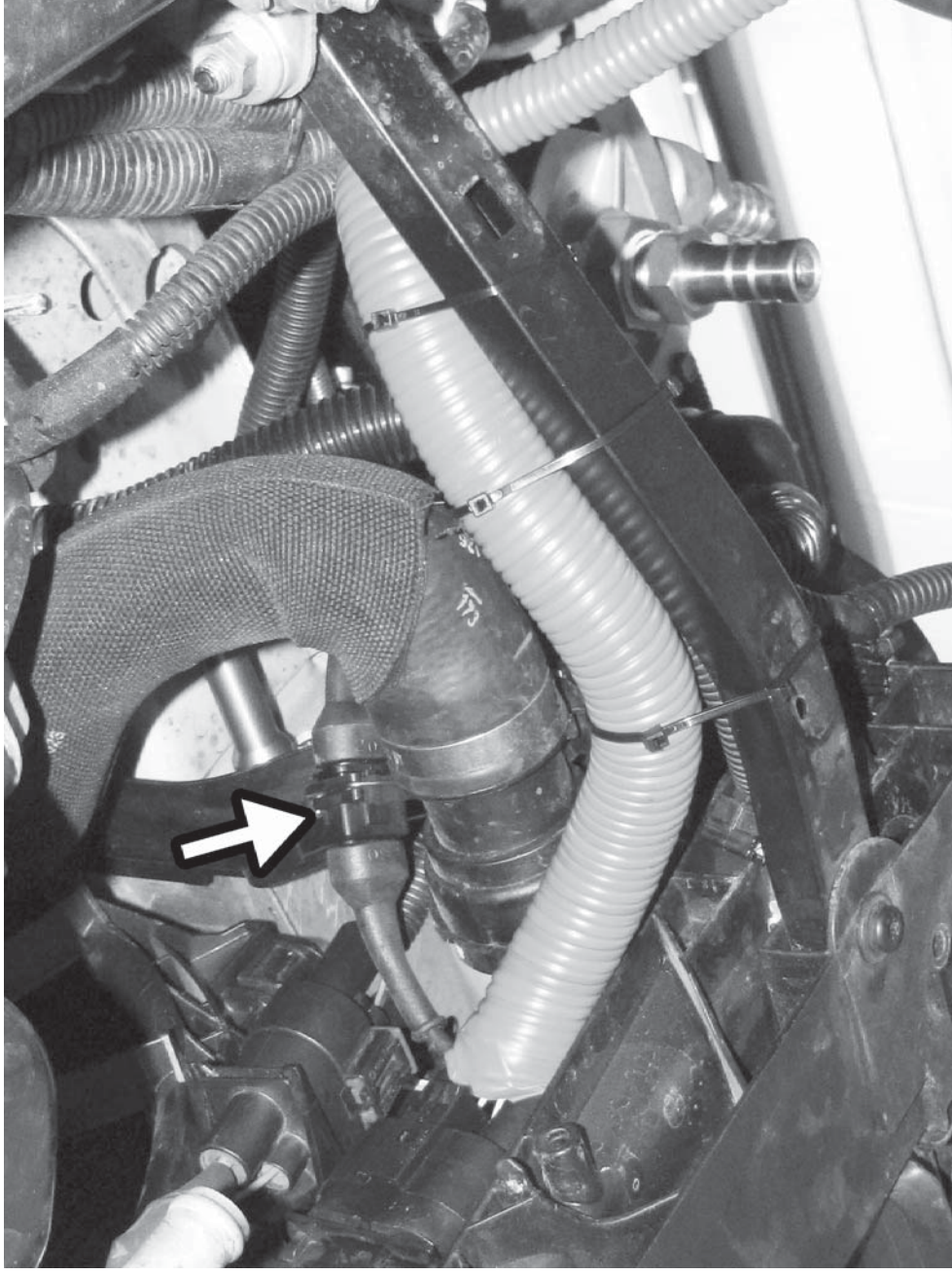

126) With the same hole saw used to cut the left side, cut a hole in the right radiator air duct near the outlet of the APR radiator.

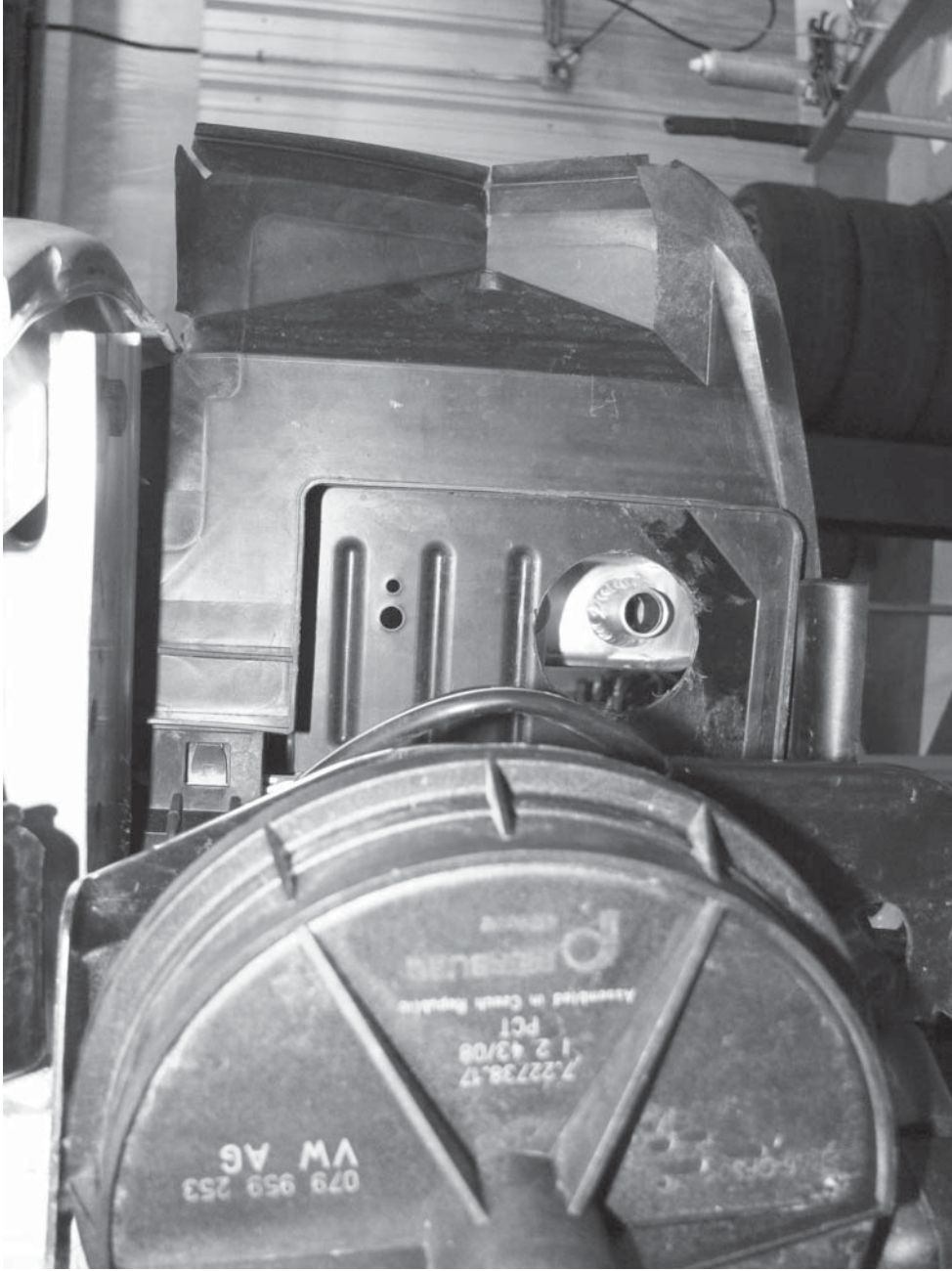

127) Extend the non-curved end of the molded hose with the supplied barbed fitting. Connect the curved side of the hose to the side (inlet) of the APR pump, and the straight side of the hose to the outlet of the radiator. Route the hose between the secondary air pump and the radiator core support. Secure all fittings with clamps.

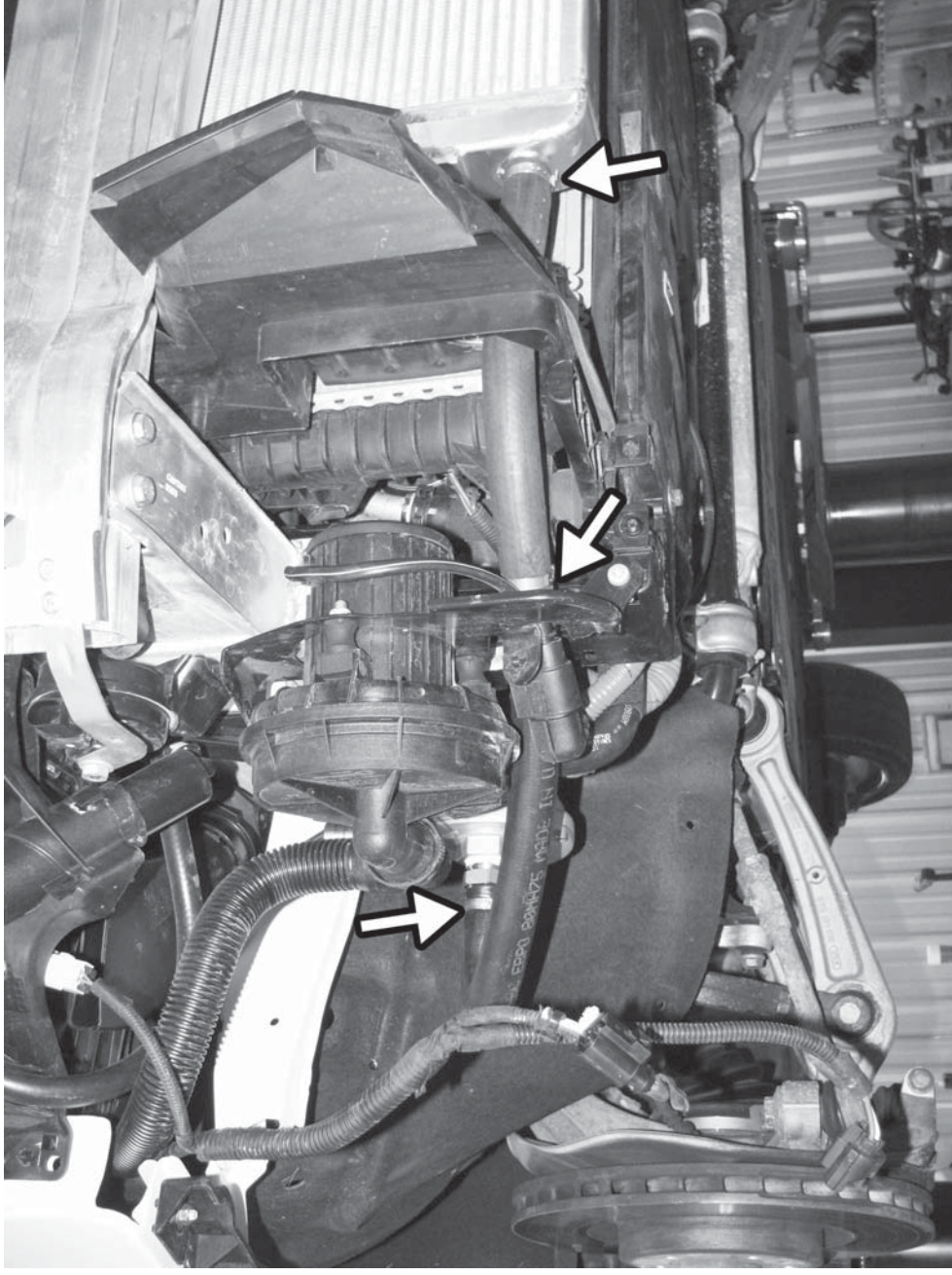

128) Install the previously assembled "Y" shaped coolant hose to the top (outlet) of the APR pump with a clamp. The two smaller ends of the hose should route up to the front of the supercharger.

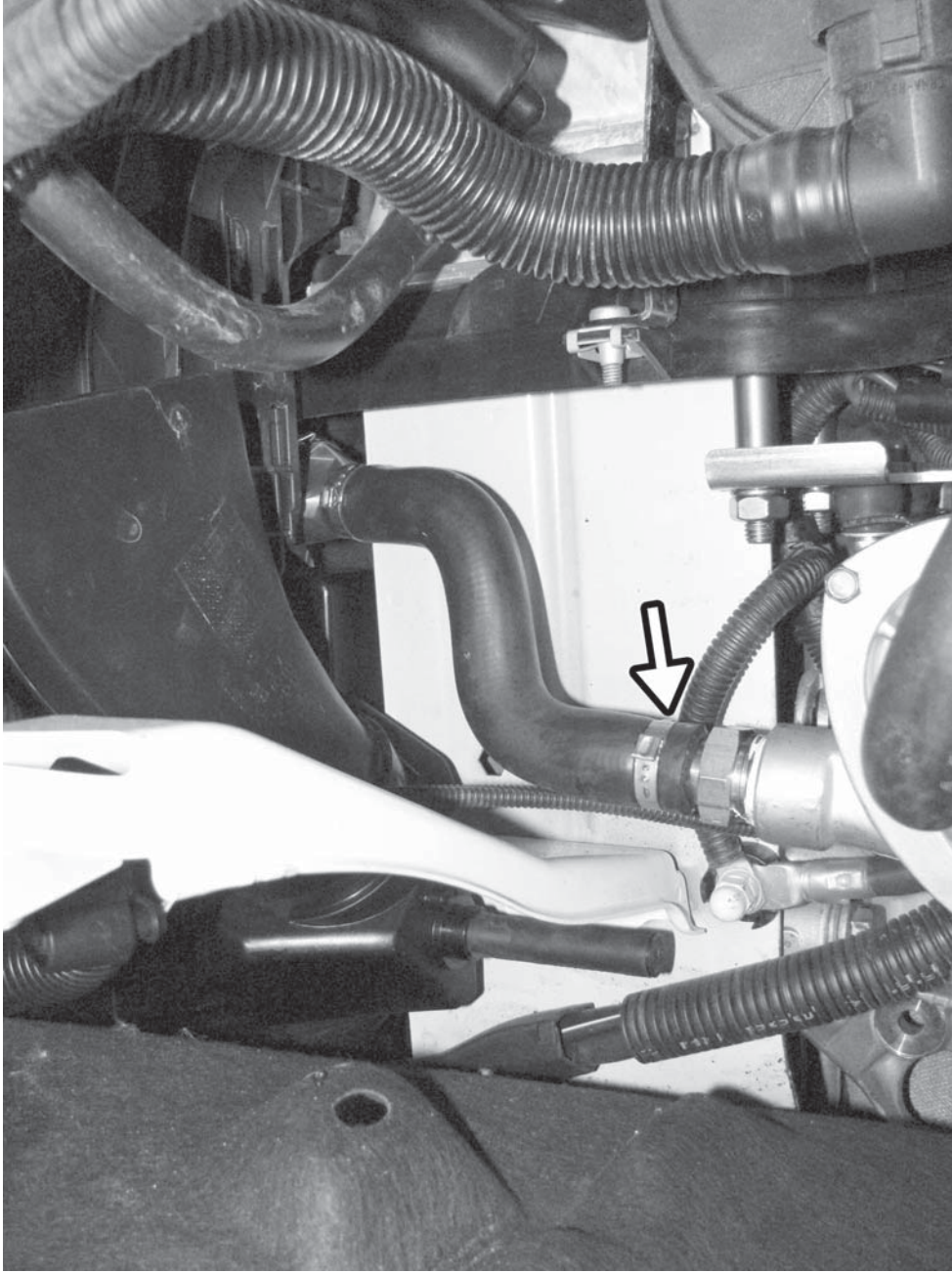

129) Install the two smaller coolant hoses on the fittings on the front of the supercharger. Affix a cable tie on the hoses to prevent them from falling.

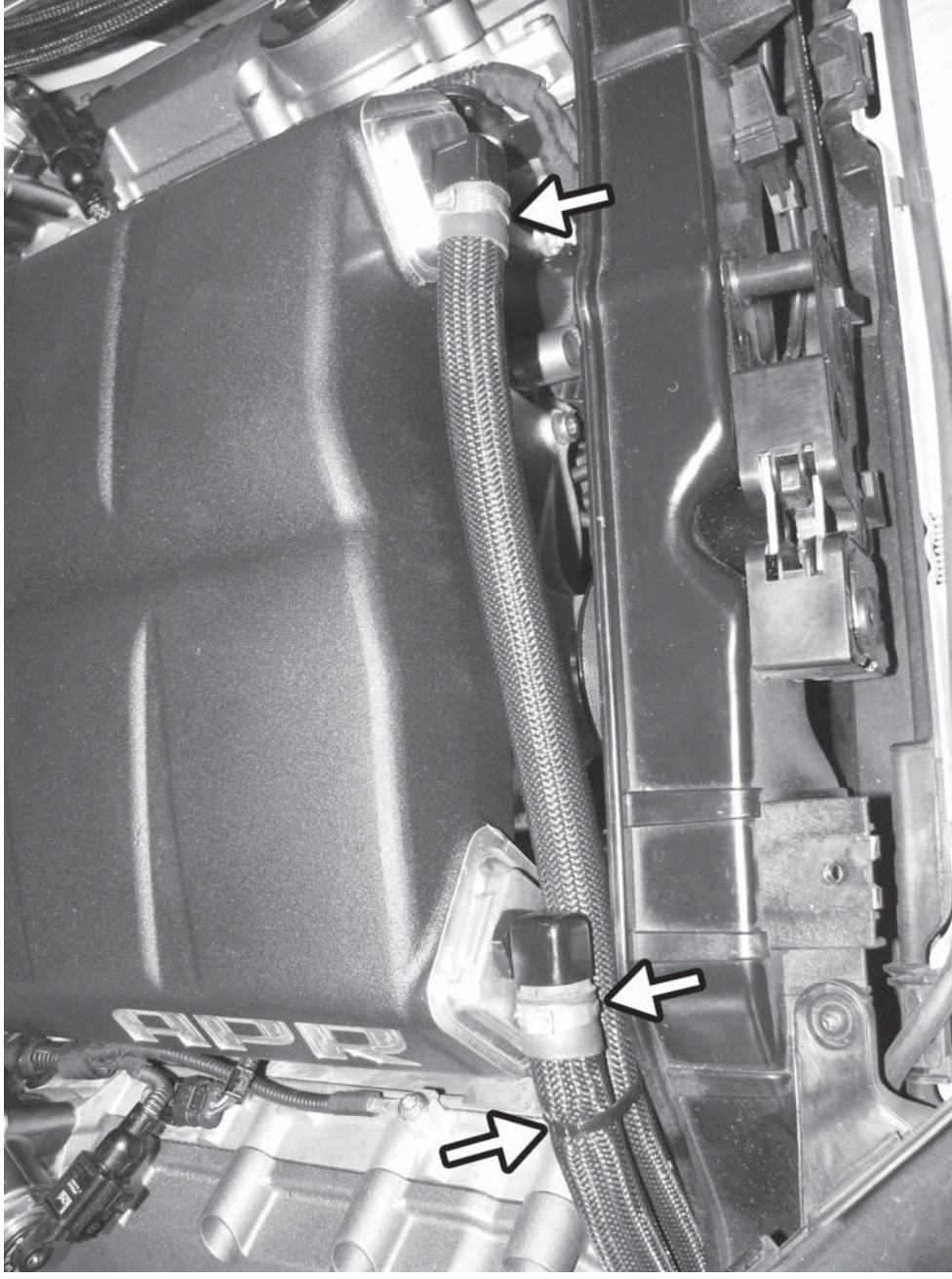

130) Reinstall the airbox inlet on the car. Make sure the tabs on the rubber section are correctly aligned to prevent collapse.



131) Reinstall the two T30 screws connecting the top corners of the core support to the fenders. Also reinstall the two T30 screws connecting the bottom of the core support to the core support braces.

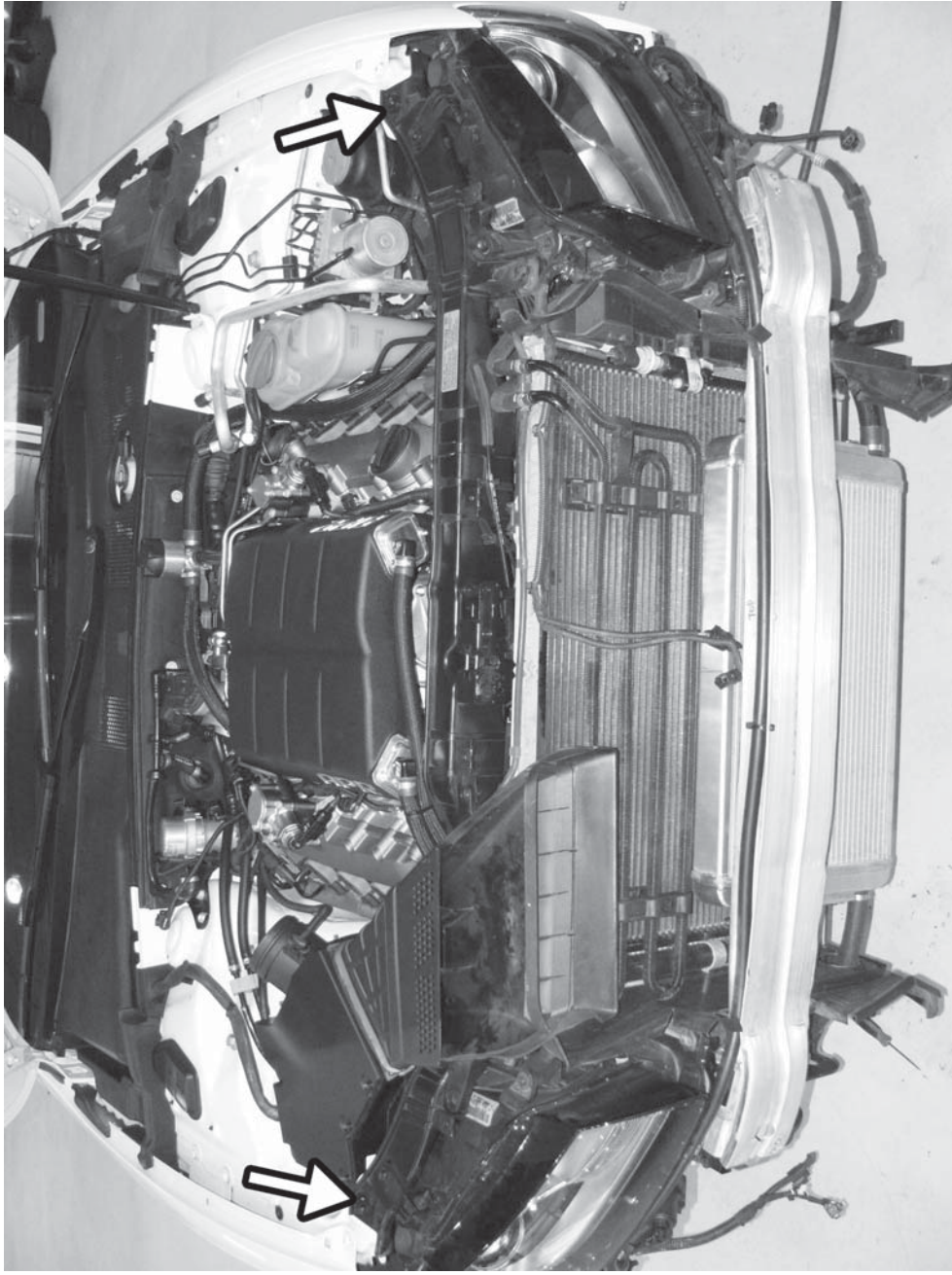

132) Reinstall the hood latch cable and reclip the junction box to the top of the radiator core support.

Also, reconnect the coolant bleed line to the expansion tank.

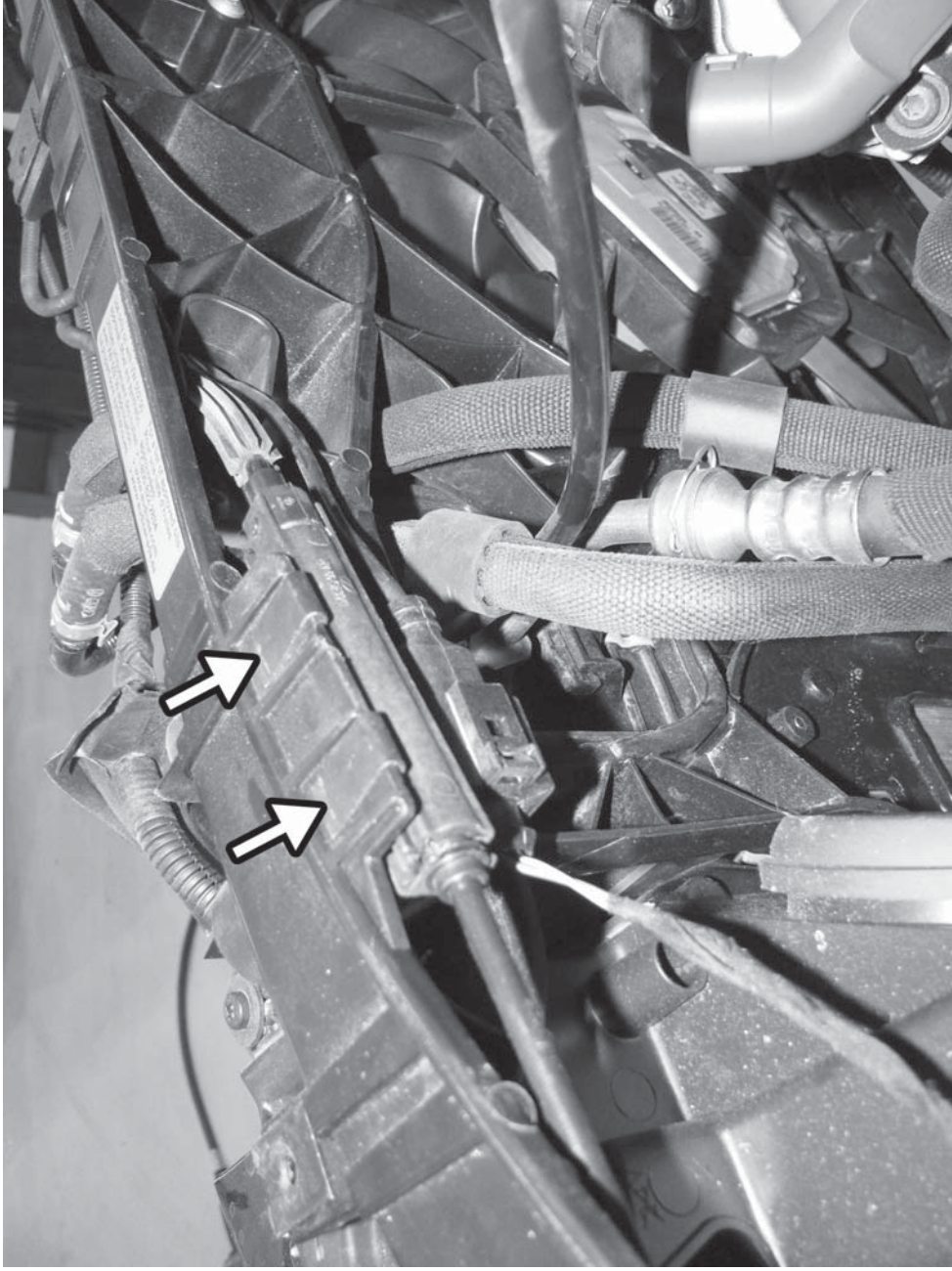

133) Bringing the bumper back towards the car, reconnect the Homelink transmitter and the outside air temperature sensor. Reconnect the left and right fog light harnesses.



134) Reinstall the two T25 screws connecting the center of the grille support to the core support.

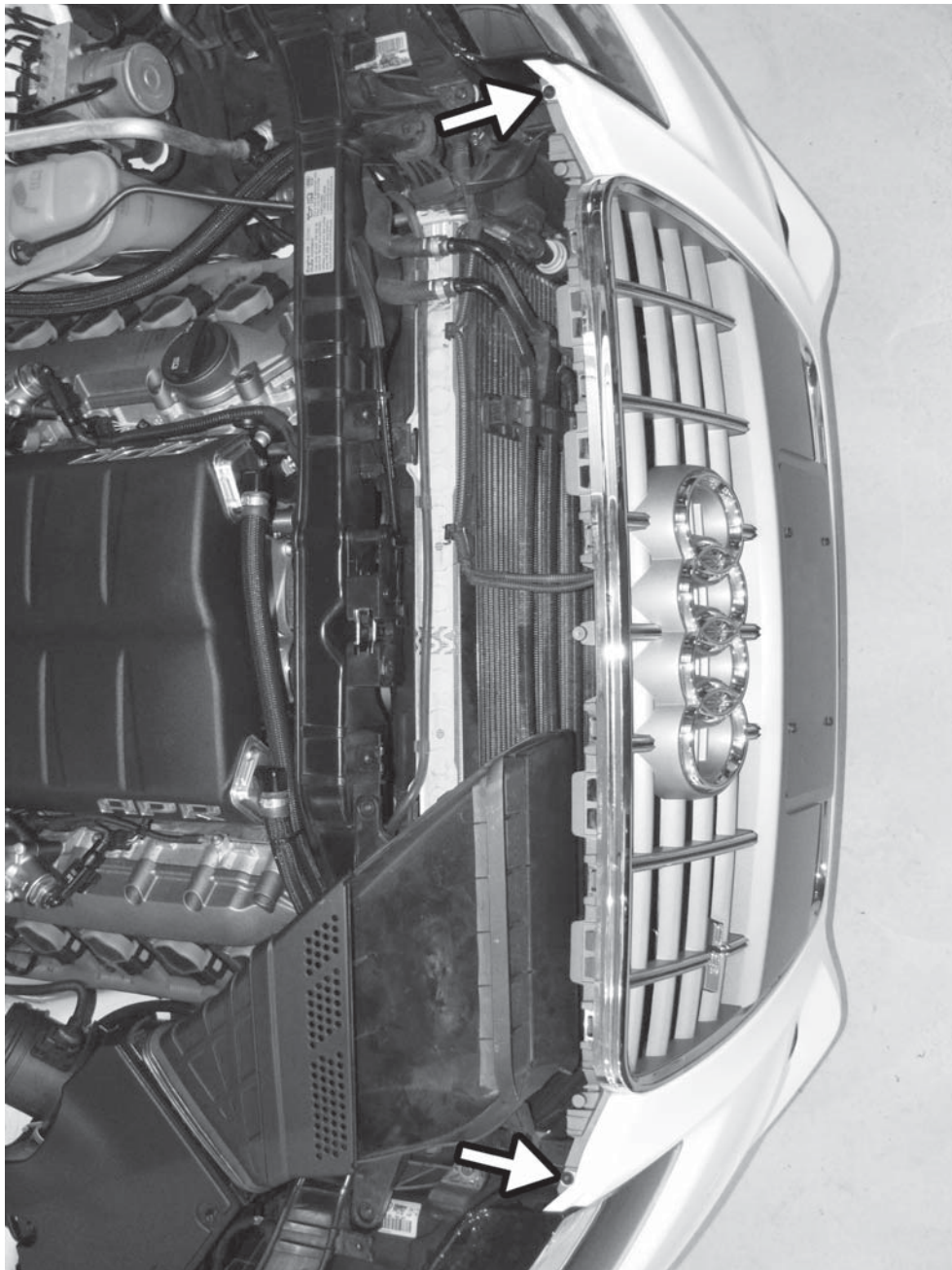

135) Reinstall the upper bumper trim cover and fasten with the four T30 screws.

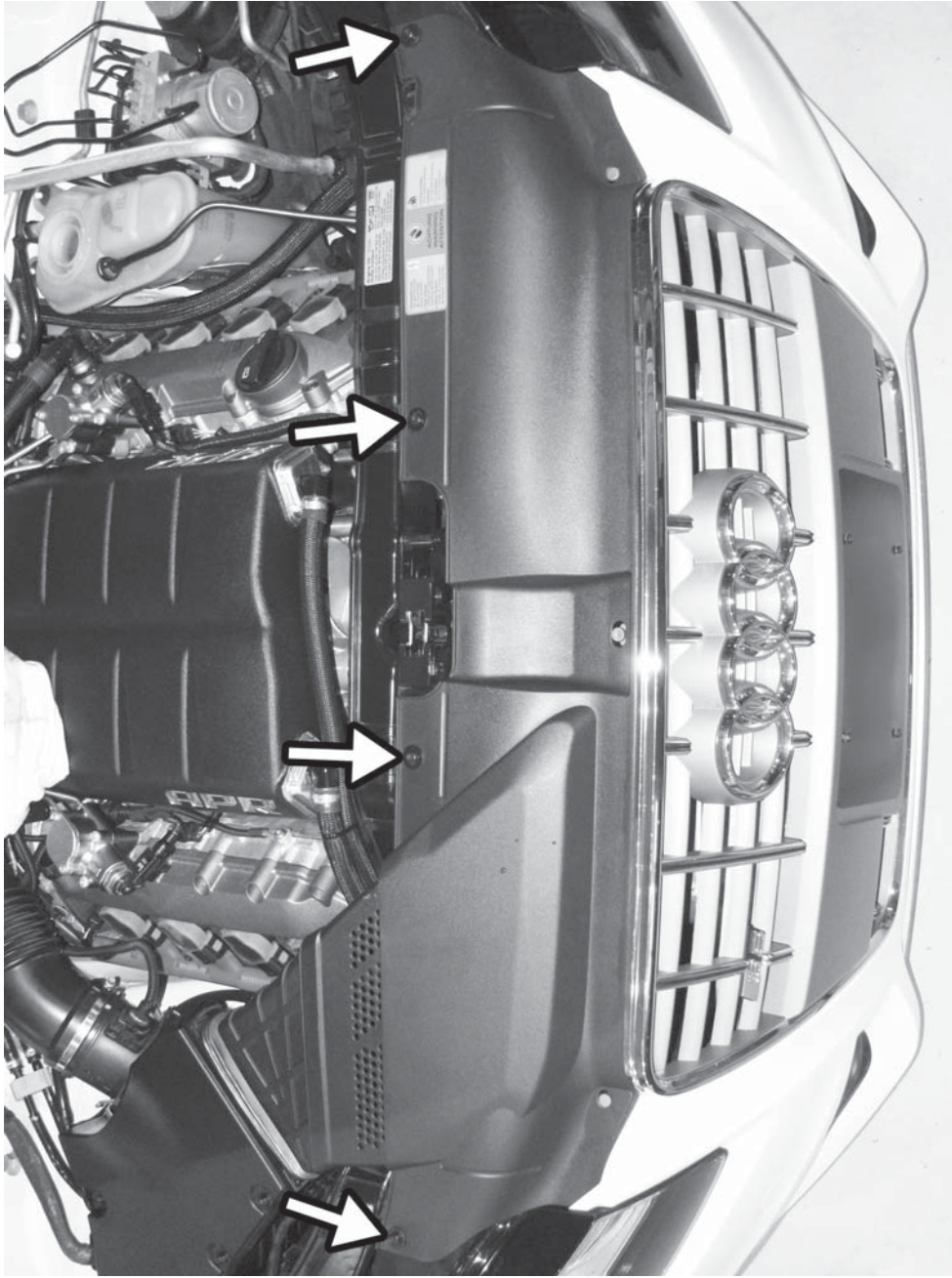

136) Disconnect the MAF connector and remove the 90° housing from the back of the plug. Cut the purple/green (#3) wire about an inch from the back of the connector, and then reattach the 90° housing. Reconnect the MAF connector.

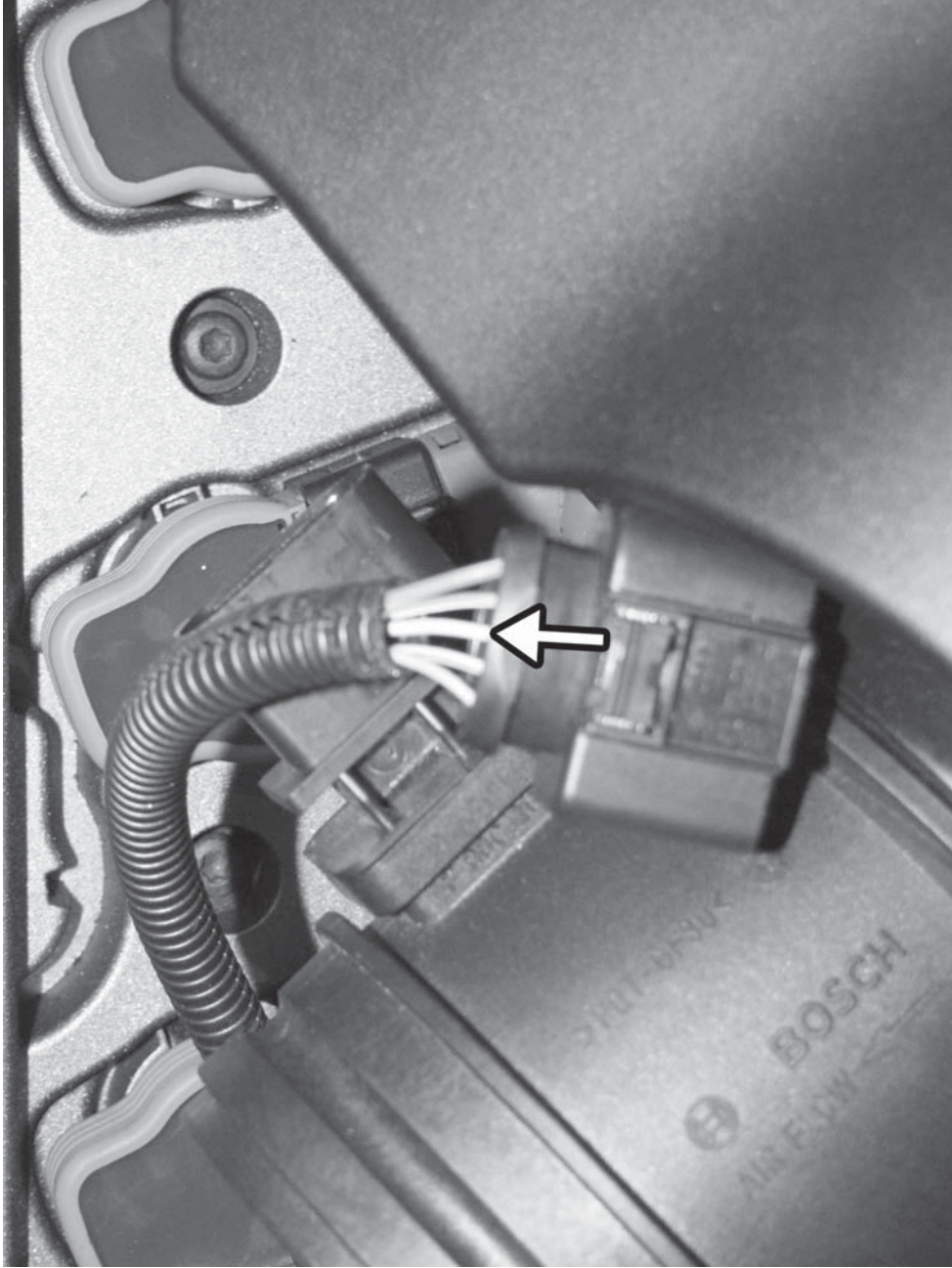

137) Trace the MAF wiring loom back to where it meets a taped junction behind the right cylinder head. Carefully cut away the electrical tape to expose the wires, and pull the same purple/green wire from the MAF connector.

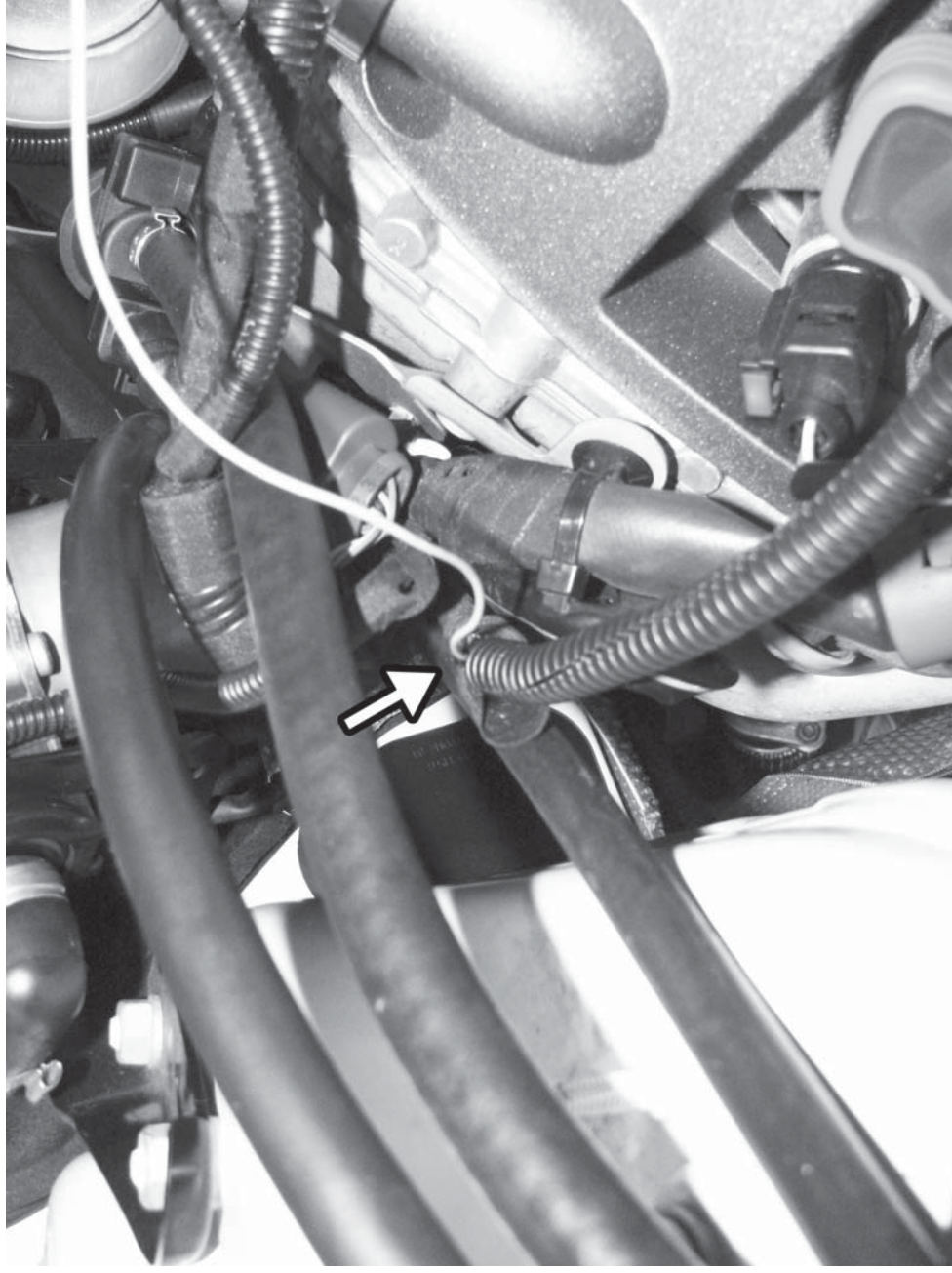

138) Connect the supplied wiring harness to the Intake Air Temperature on the left side of the supercharger. Route the wiring in front of the oil filter and under the fuel distribution assembly towards the back of the right cylinder head.

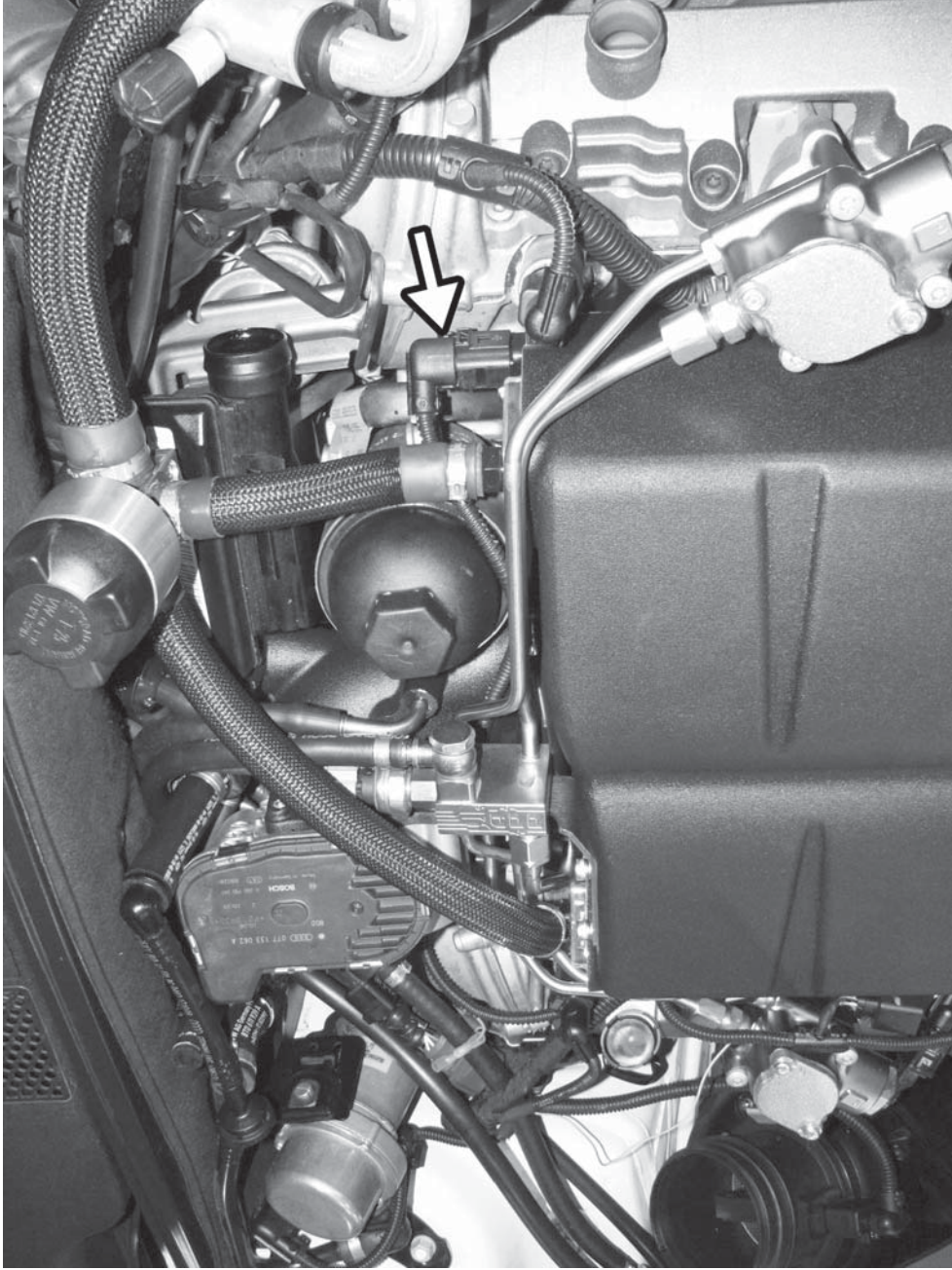

139) After trimming to length, crimp the purple and green wire to the butt connector on the APR wiring harness. Heat the connection with a heat gun until the solder inside the connection is flowing.

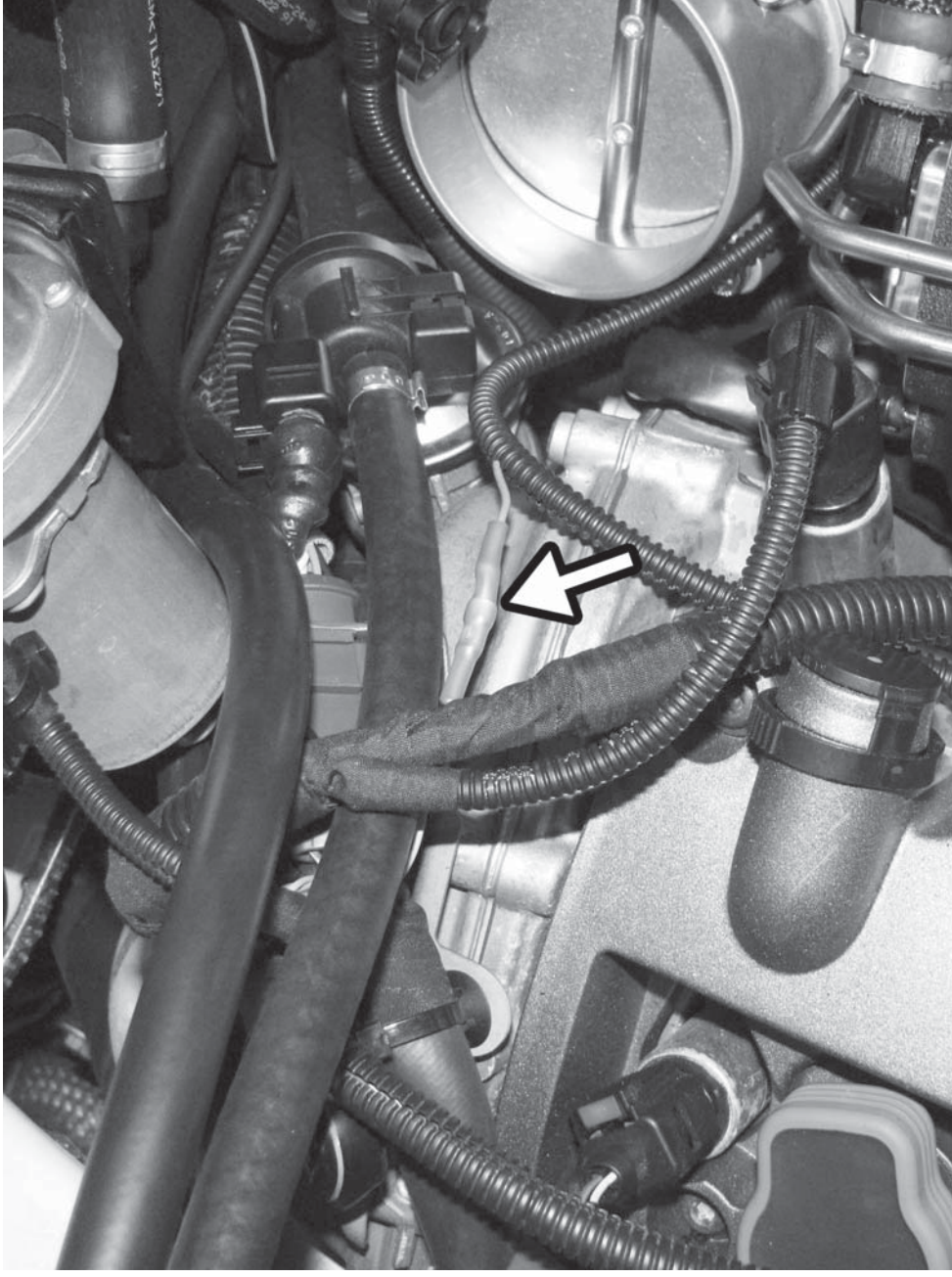

140) Using the supplied 4mm allen screw, connect the ring terminal to the cylinder head. There should be two electrical connections that used to run down the right cylinder head to the front of the engine. They can be wrapped up and cable tied out of the way in this area.

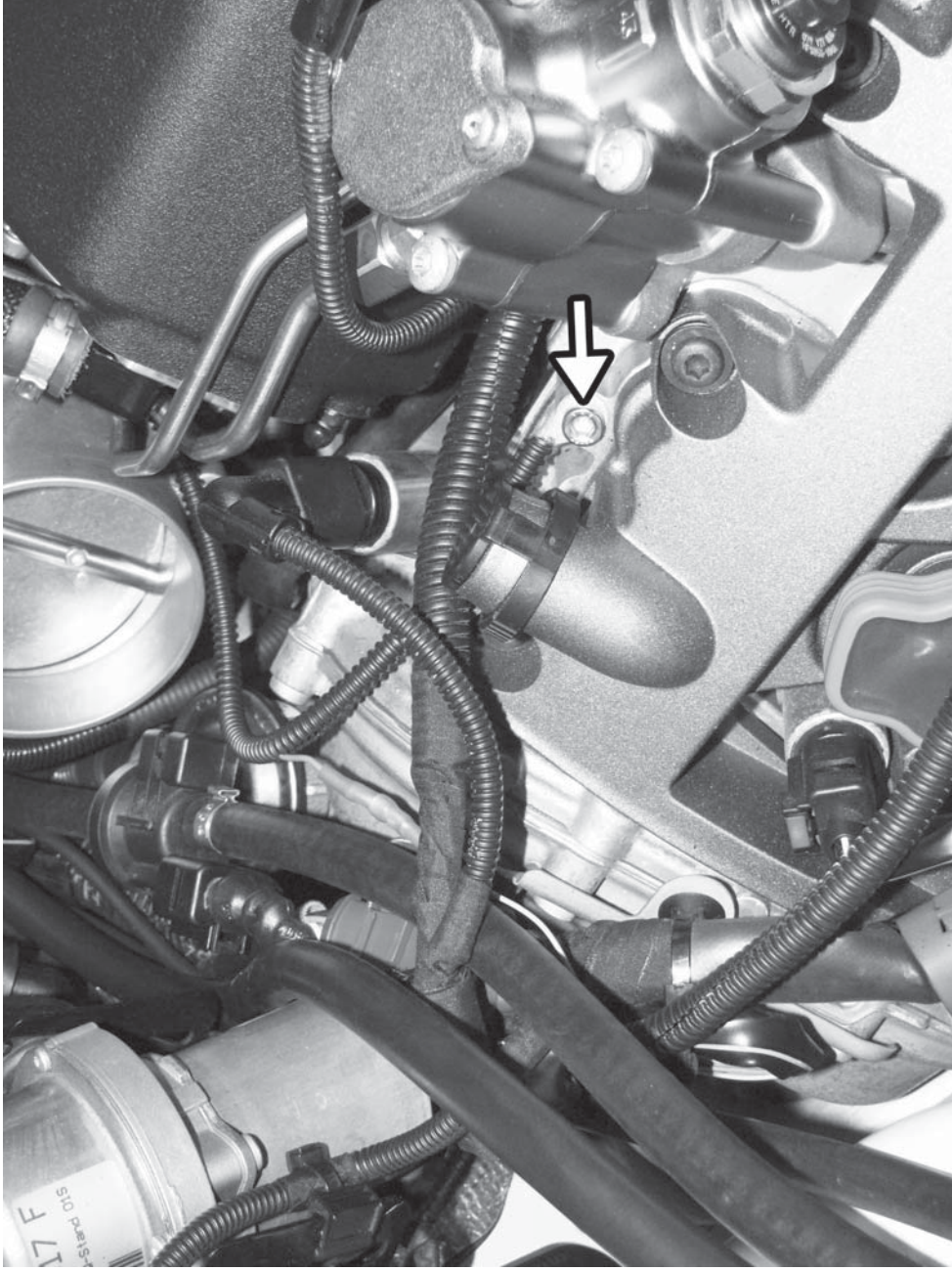

141) Reinstall the stock inlet hose between the throttle body and MAF sensor using with the two hose clamps. Reconnect the two vacuum lines, one push on and one with the four way connection to the inlet pipe near the throttle body.

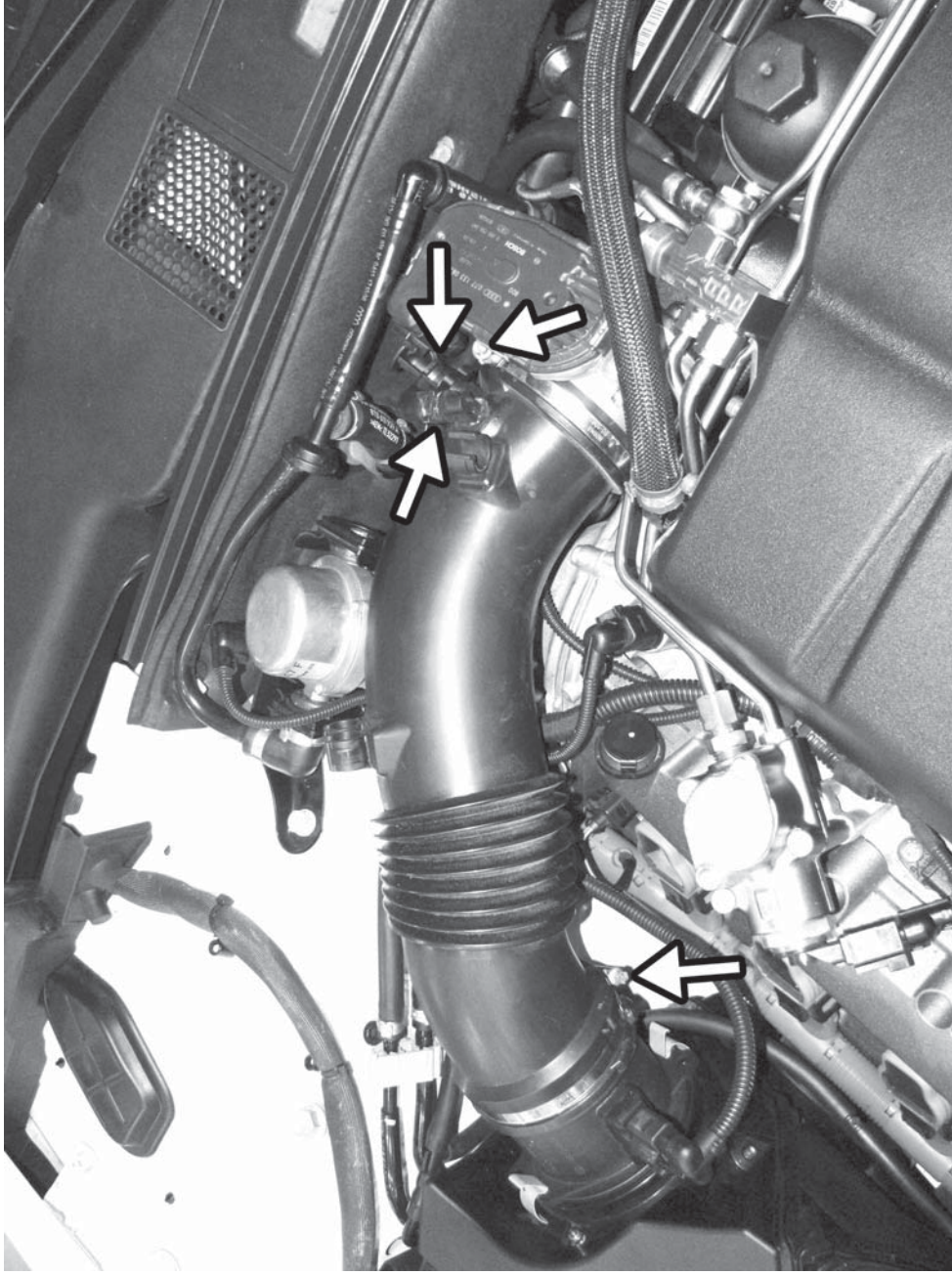

142) Reinstall the PCV hose between the oil separator and the left valve cover.

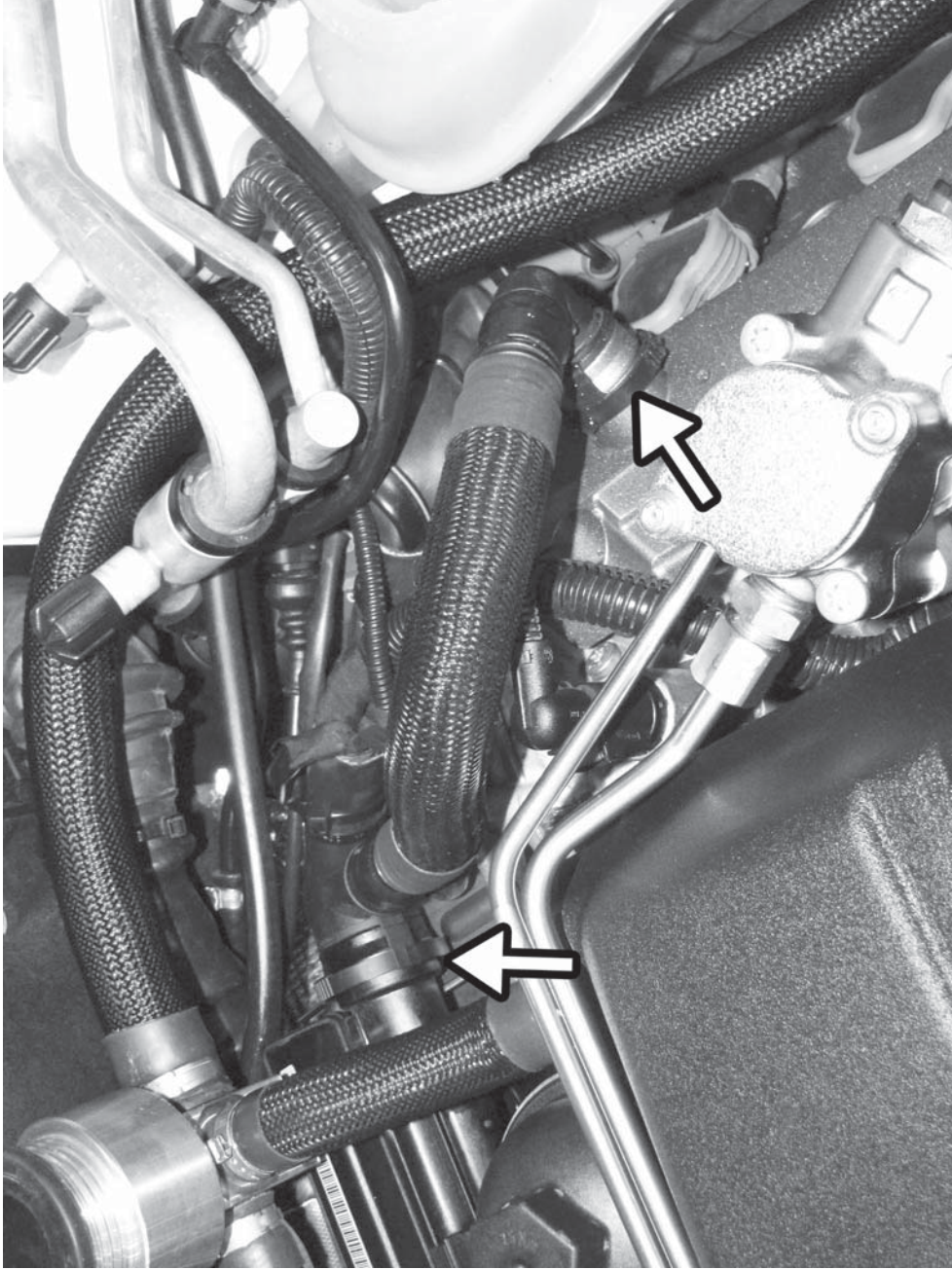

143) Reinstall the two 10mm screws behind the fender liner that connect the bumper to the fender.

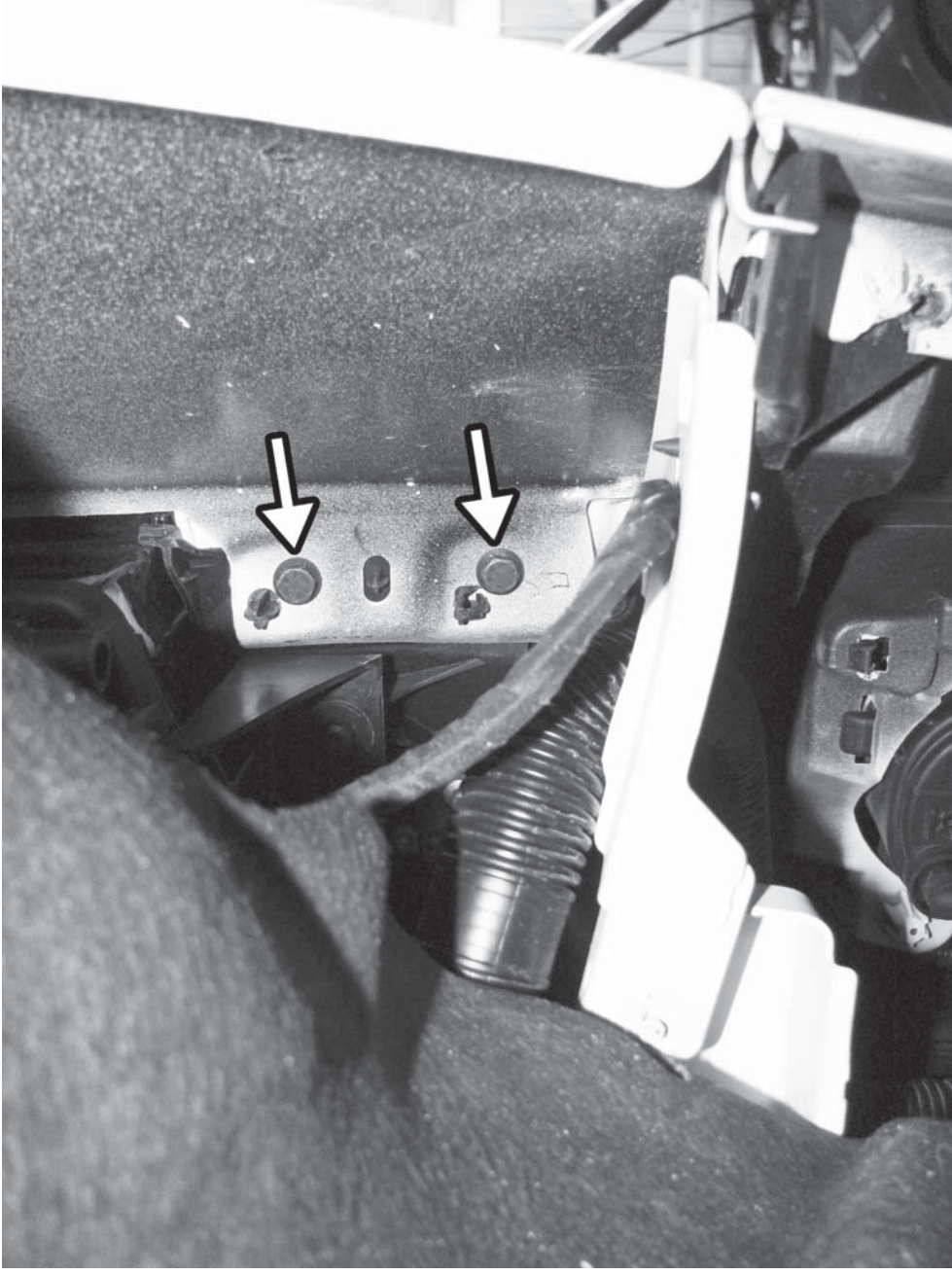

144) Install the three T30 Torx screws and the two push tabs into the fender liner. Repeat on both sides.

Reinstall both front wheels and torque wheel bolts to 125Nm.

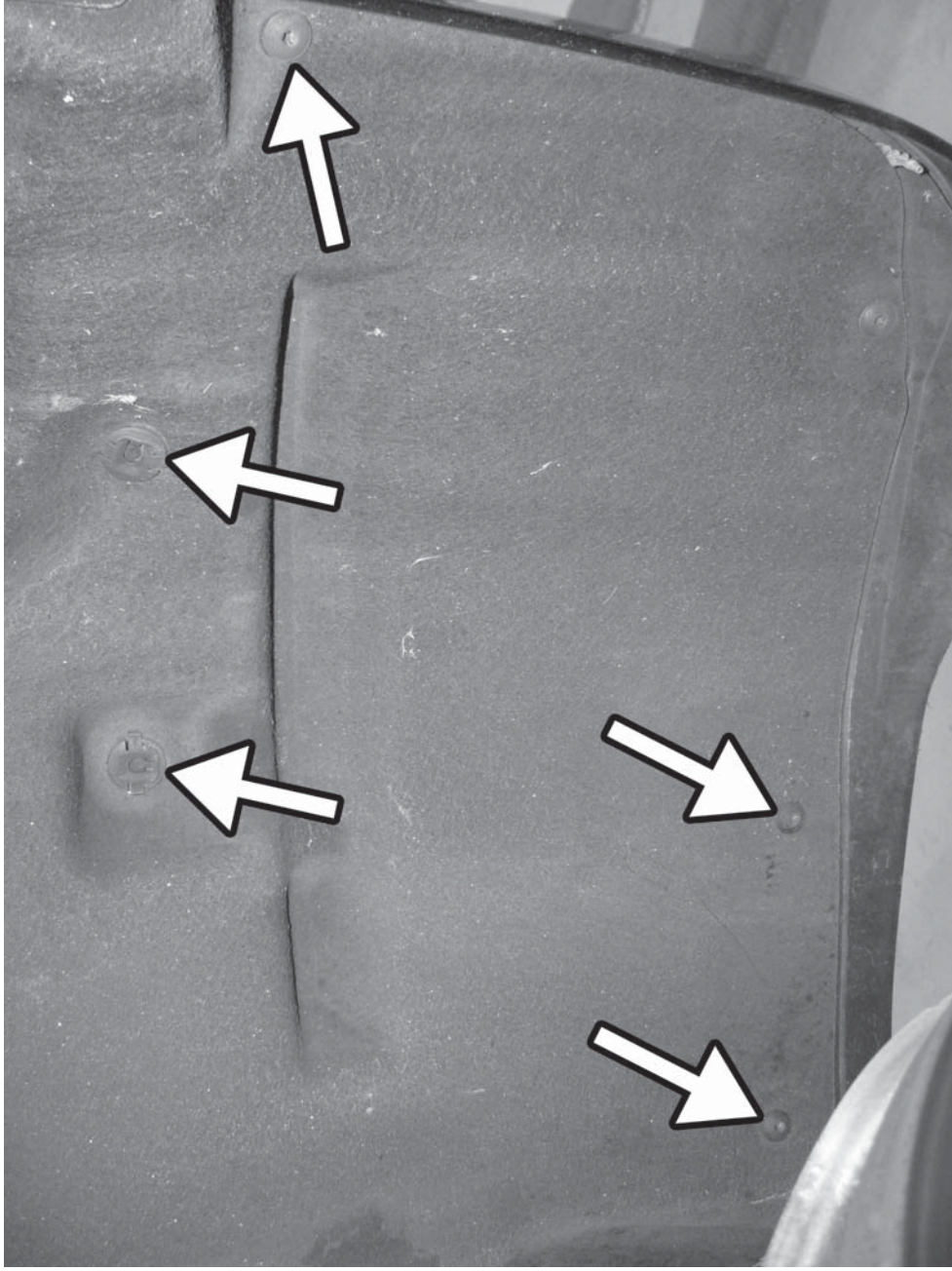

145) Reinstall the belly pan on the car and install the four T30 torx screws that connect the bumper cover to the belly pan.

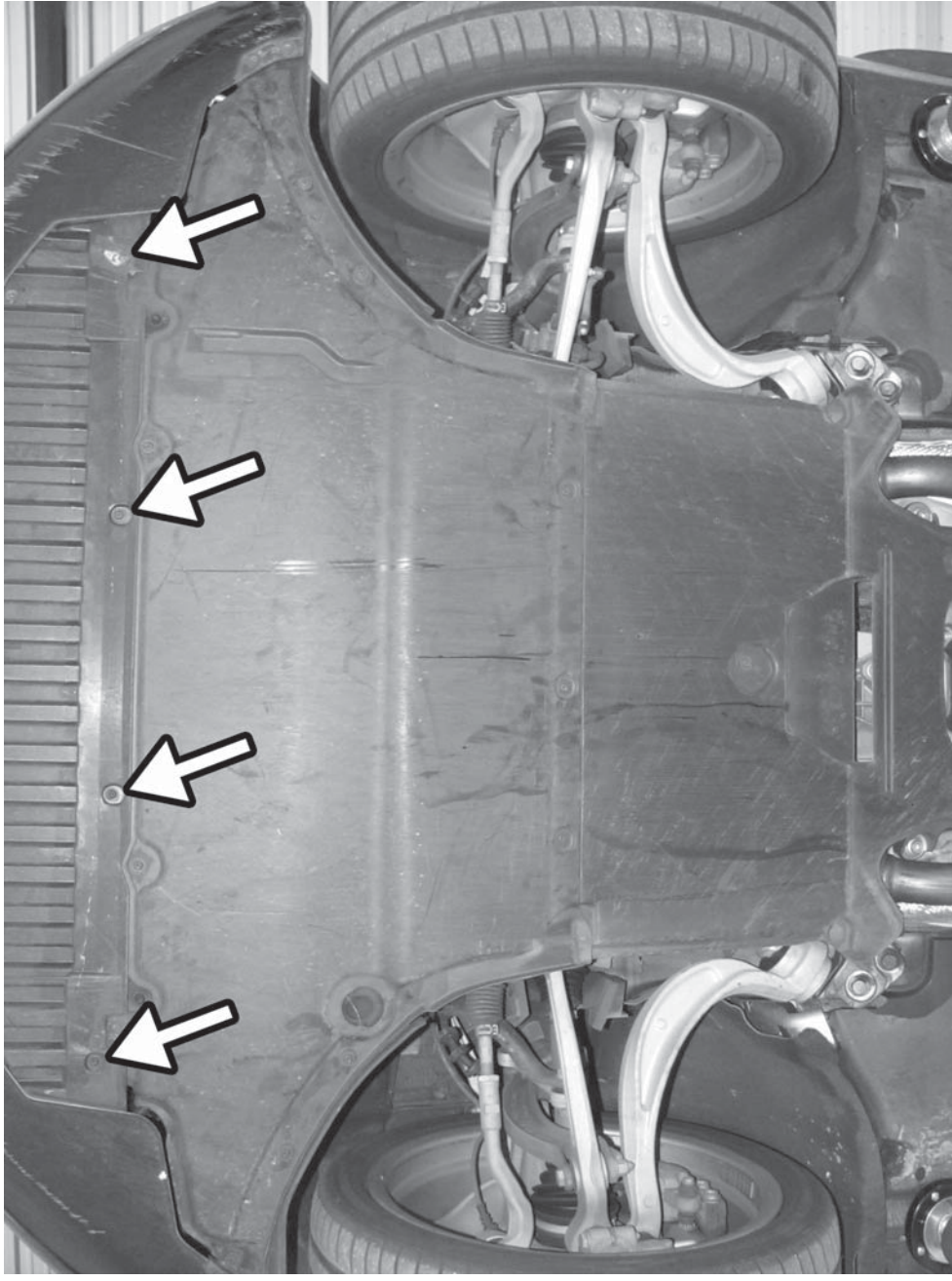

146) Reinstall the eleven quarter turn fasteners on the belly pan.

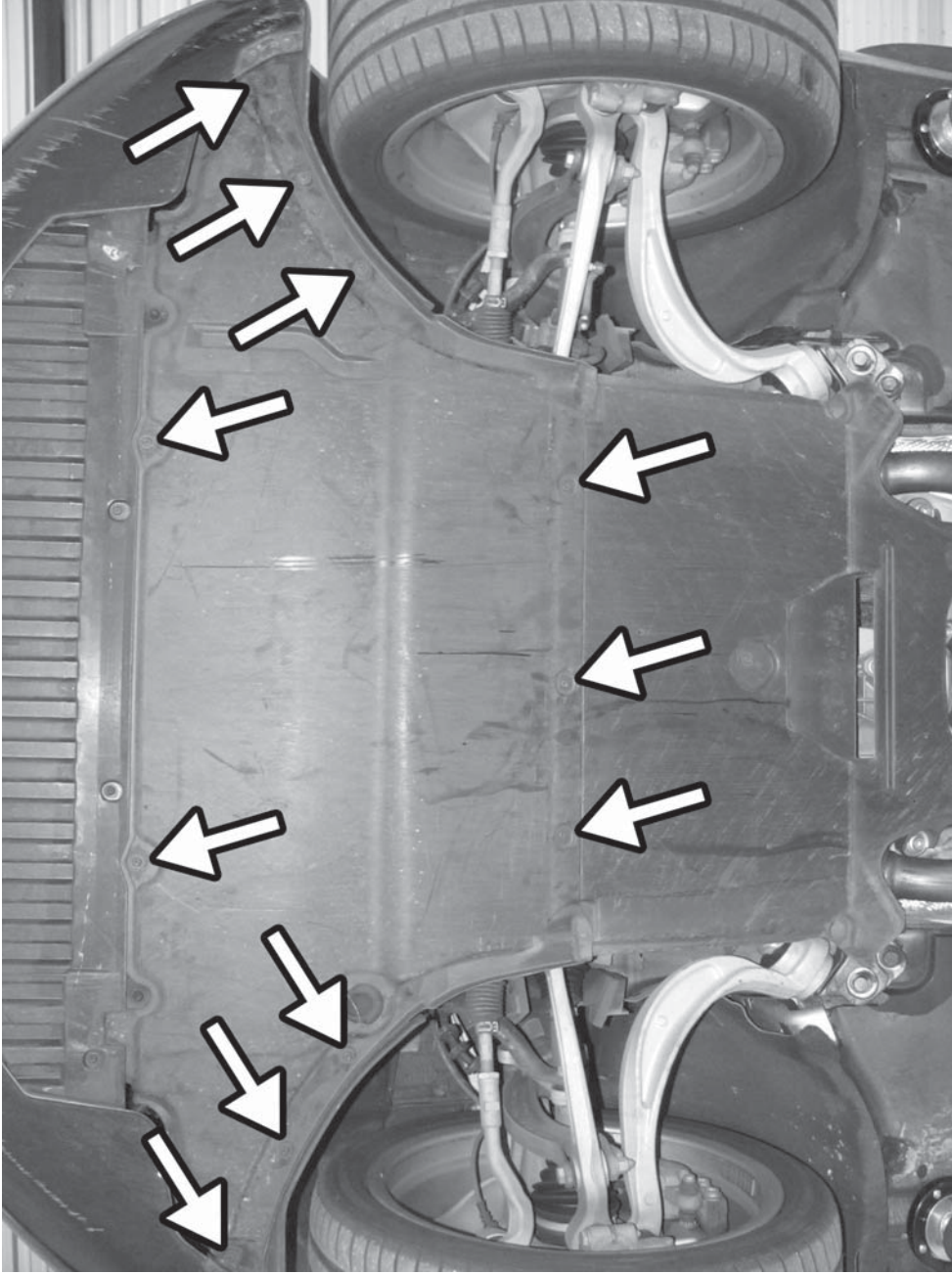

147) Reinstall the upper bumper trim cover and fasten with the four T30 screws.

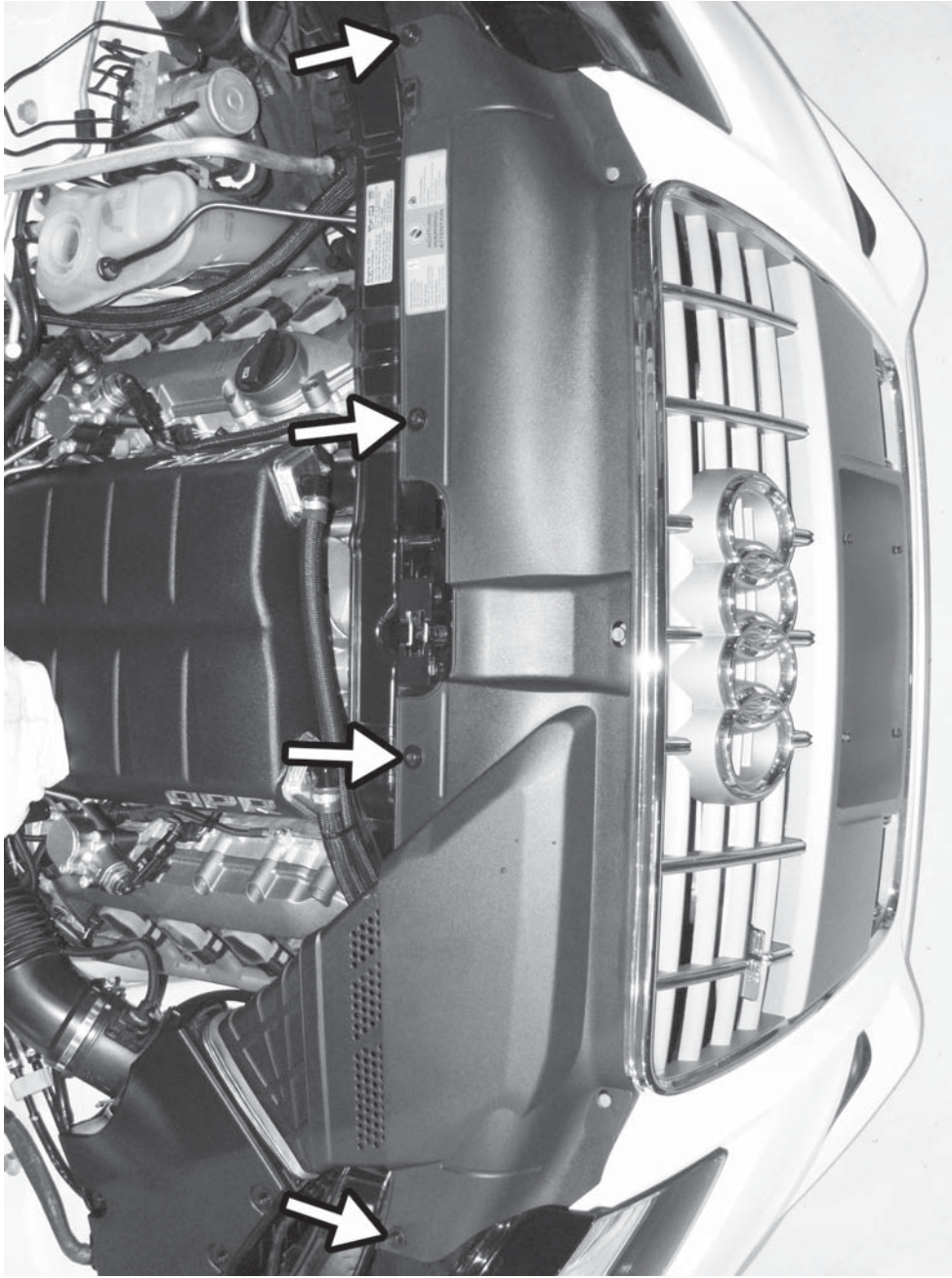

148) Reinstall the two T25 screws connecting the center of the grille support to the core support.

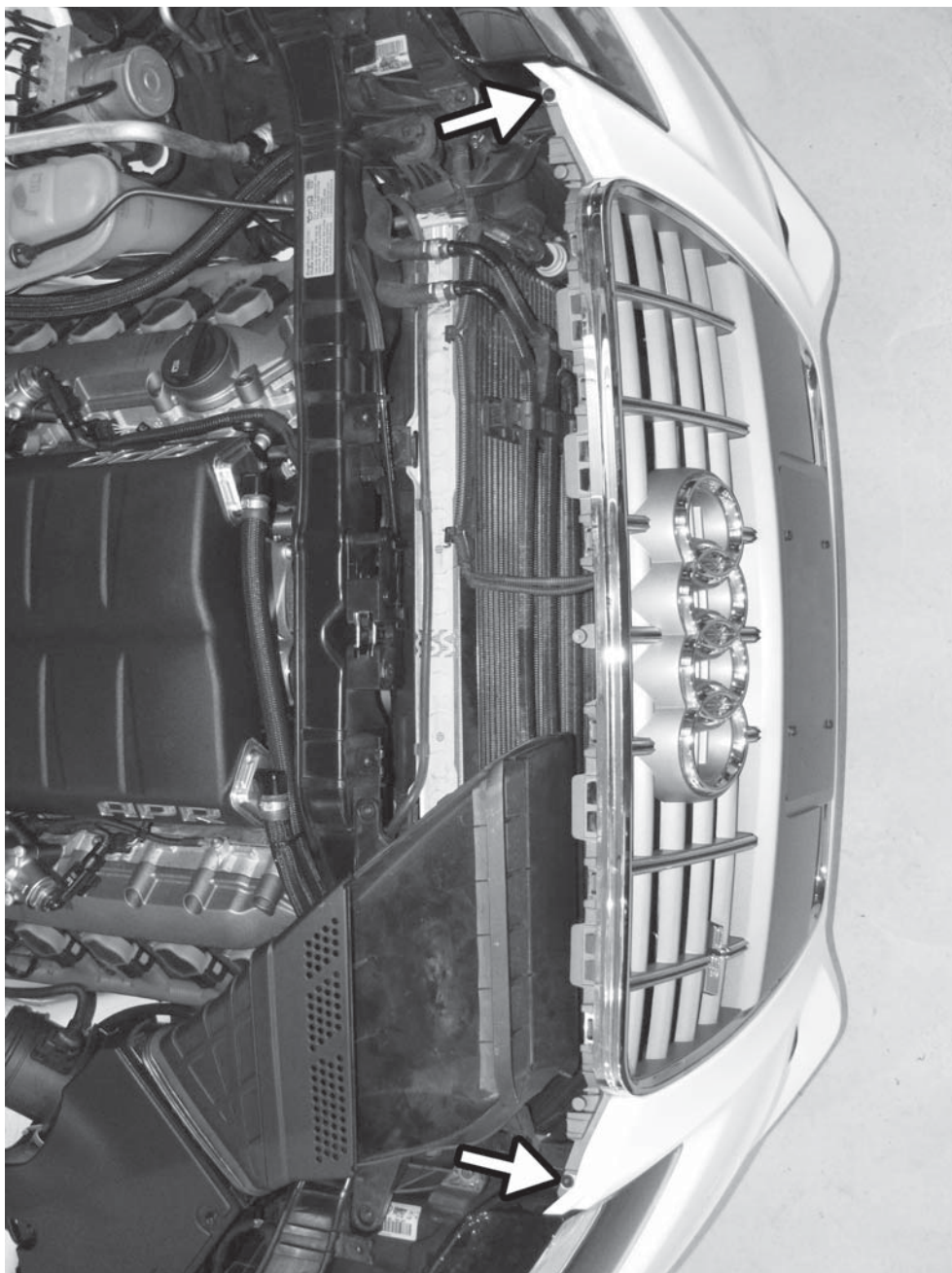

149) Reinstall the upper bumper trim cover and fasten with the four T30 screws.

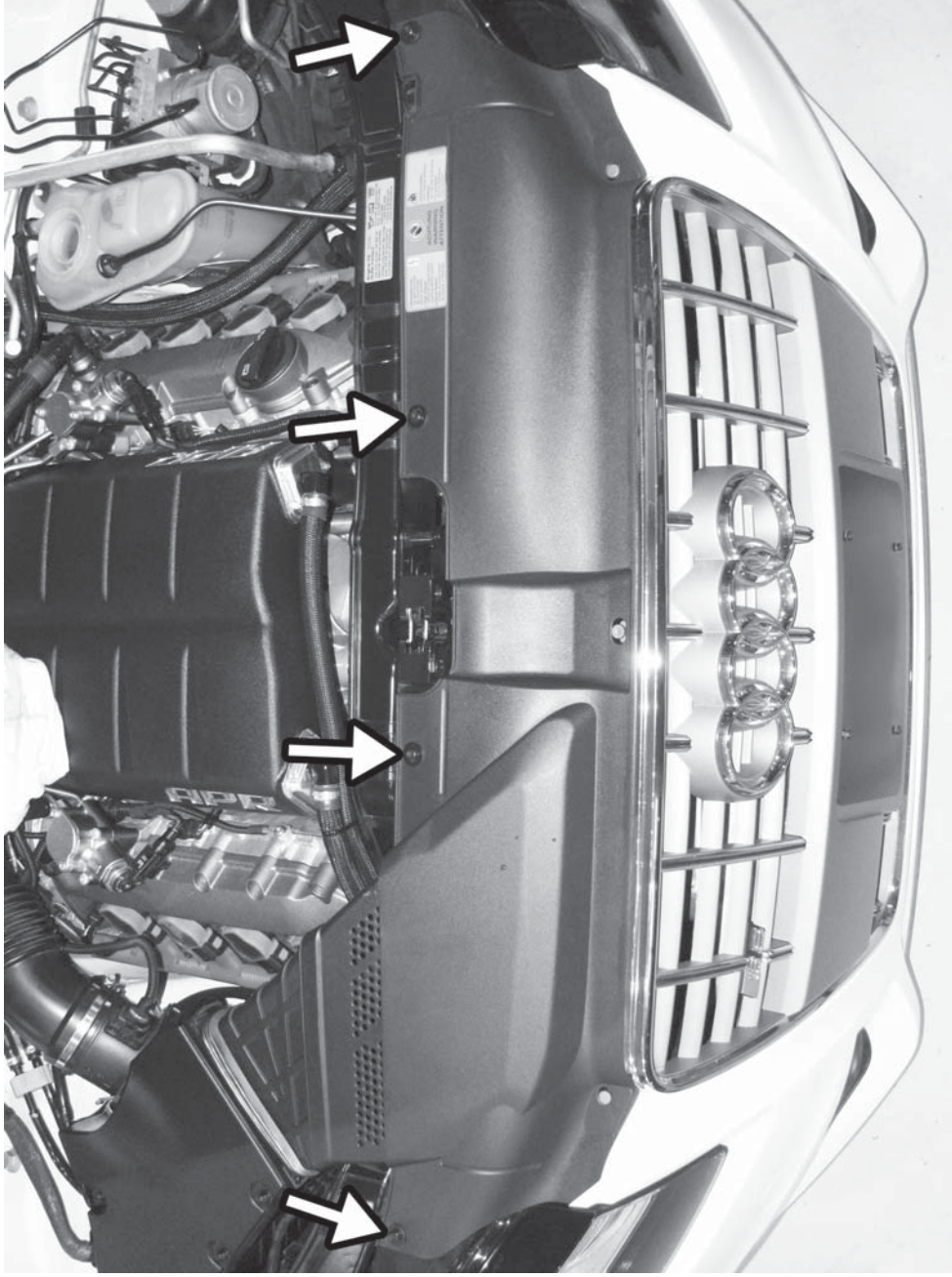

150) Fill the coolant in both the engine coolant reservoir and the APR coolant reservoir with a vacuum bleeder. Following the directions of the vacuum system manufacturer. Properly bleeding the APR cooling system is critical to the operation of the APR coolant pump and the supercharger cooling system.

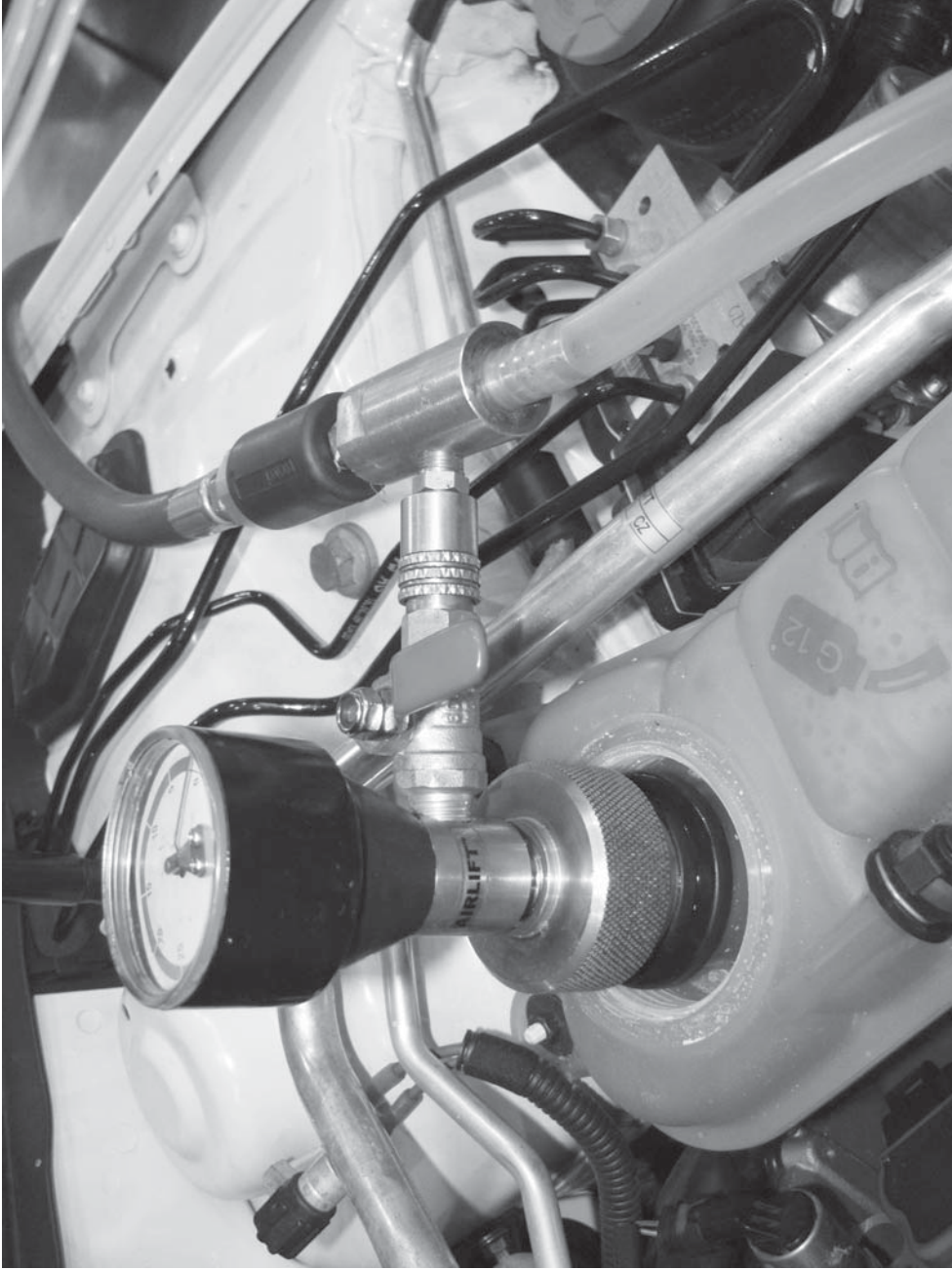

APR, LLC
4800 US HWY 280 West Opelika Alabama 36801
